

## 3GR-FSE ENGINE MECHANICAL

### Cylinder Head Fitting Parts

- The cylinder heads are made of a lightweight and highly rigid aluminum alloy. Also, the VVT-i supply oil passage has been separated from the cylinder heads to simplify the oil passage in the cylinder heads.
- The cylinder head gaskets are the two-layer metal type. Shims are provided around the bores to ensure sealing performance and durability.
- The cylinder head covers are made of a lightweight aluminum alloy. They are tightened to the cylinder heads by way of fixed-dimension flanges along their periphery to ensure the proper sealing performance.
- OCVs (oil control valves) for Dual VVT-i are mounted on both the right and left cylinder head covers.
- The cylinder head cover gaskets are made of acrylic rubber, which excels in heat resistance and oil resistance.

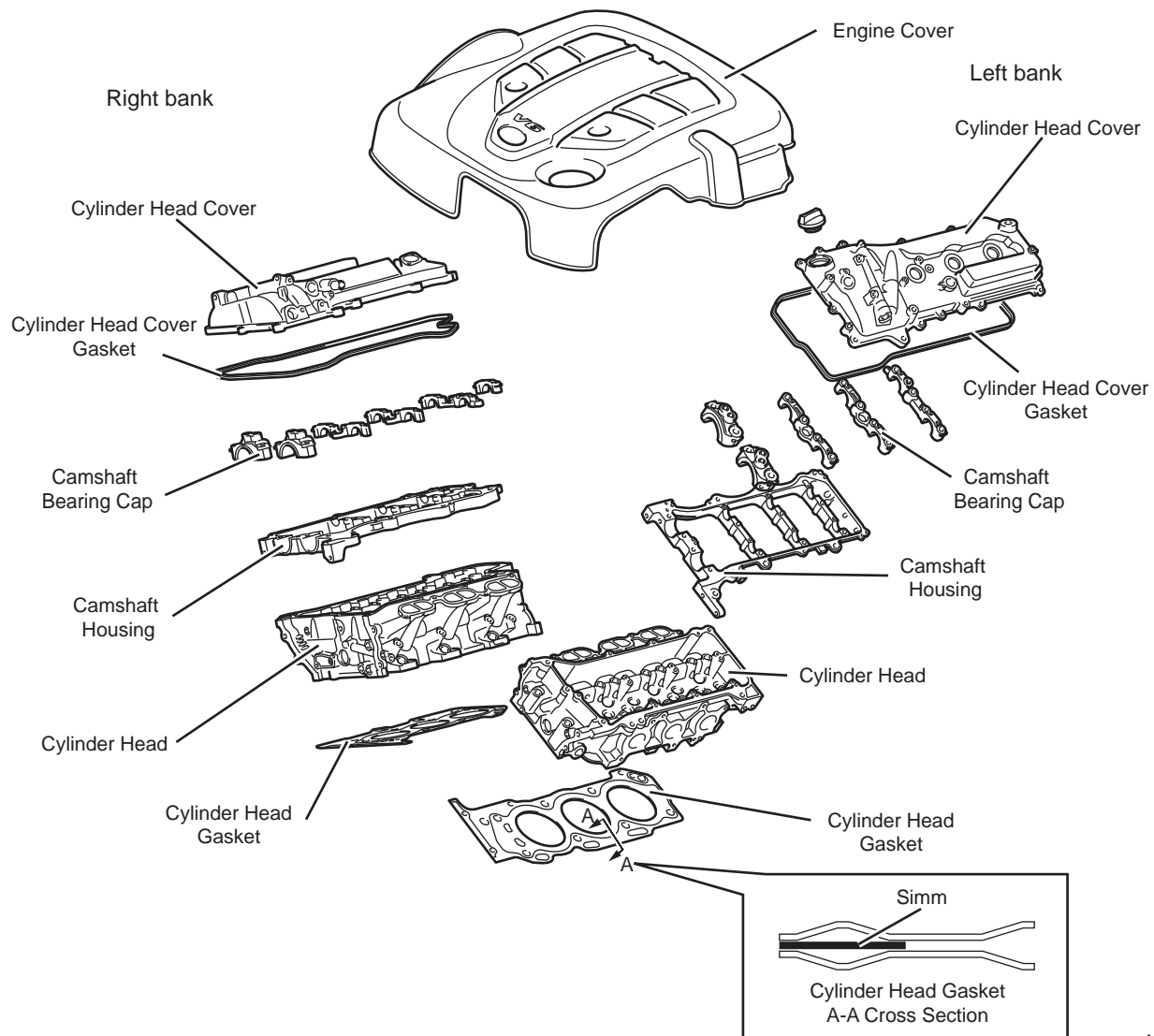

## Cylinder Head Cover

- Large baffle plates are built into the right and left head covers. By reducing the flow rate of blowby gas, these baffle plates remove oil droplets and oil mist, thus reducing the volume of oil taken away.
- Oil delivery pipes are provided to supply engine oil, in order to properly lubricate the sliding areas of the roller rocker arms, thus enhancing their reliability.

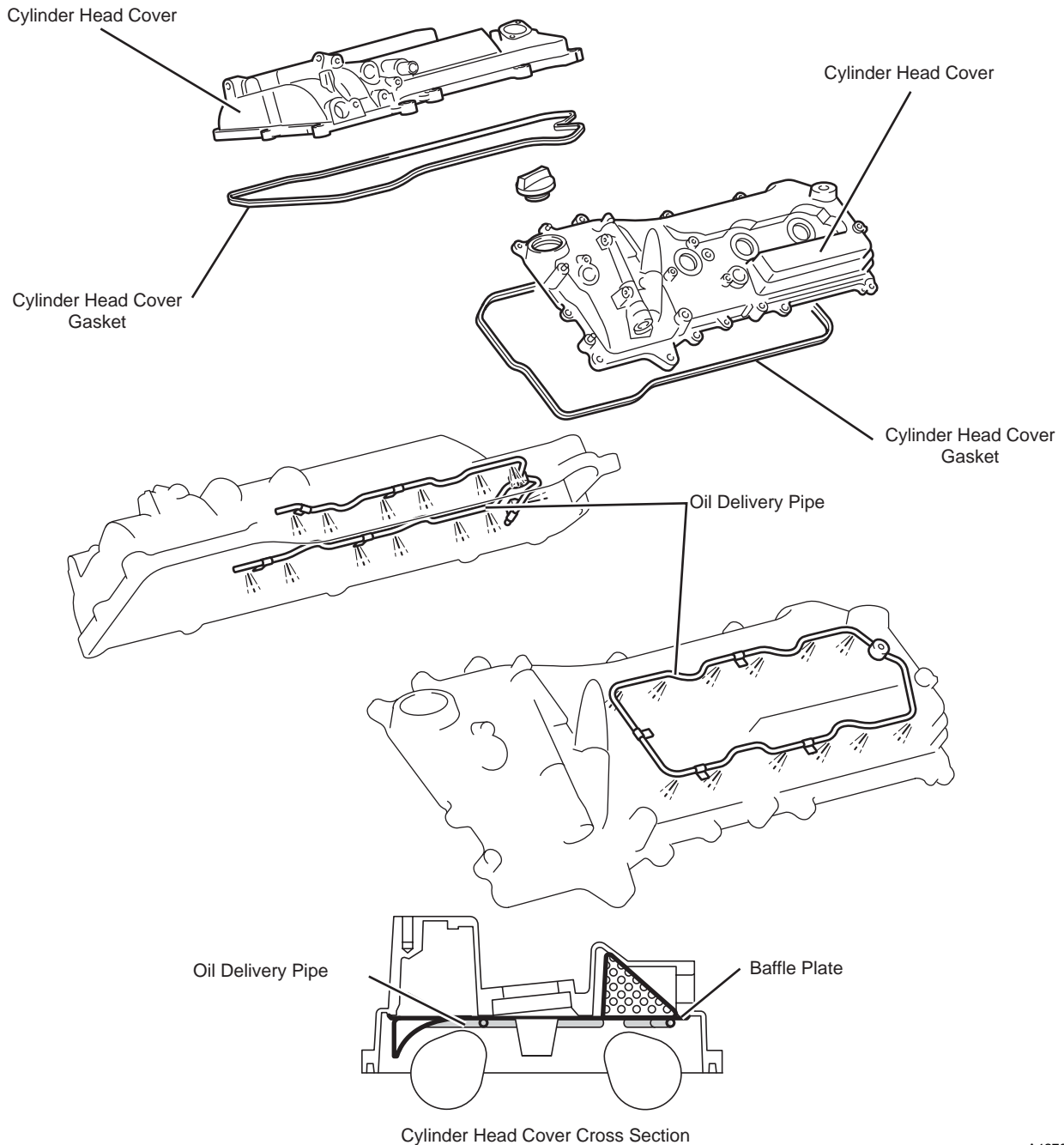

A4270058P

## Cylinder Head

- By using a two-piece construction in which the portion that receives the cam journals is separate from the cylinder head proper, the config-

uration of the cylinder head proper has been simplified. This results in weight reduction and improved serviceability.

- Pentroof combustion chambers are used. A spark plug is located practically in the center of each combustion chamber to enhance combustion efficiency and knock resistance. Furthermore, the angle between the intake and exhaust valves has been narrowed to 25.6 degrees, thus making the combustion chamber compact.
- The port configuration is an efficient cross-flow type in which the intake ports face the inside of the V bank and the exhaust ports face the outside. The intake ports have an independent, narrow-diameter construction and the exhaust ports have a Siamese construction to enhance low- to medium-speed torque. The intake ports are the vertical type that has a cutout and an edge at the bottom of each port outlet to realize a high tumble and high intake efficiency.
- The diameter of the valve stem and the outer diameter of the valve guide have been reduced to reduce intake resistance.
- The cylinder head bolts are tightened with the plastic region tightening method in order to stabilize the axial tension of the bolts.

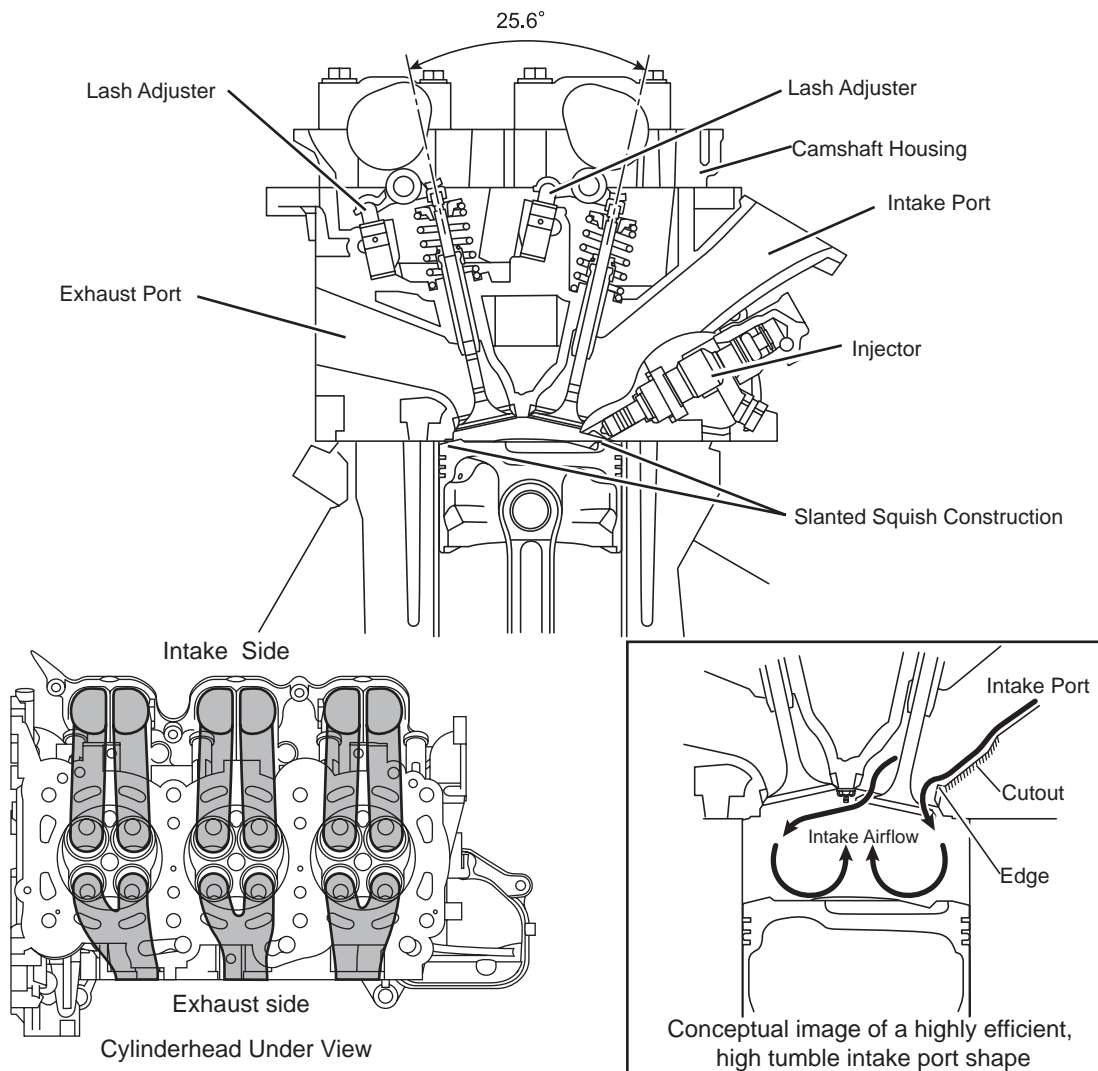

## Cylinder Block Fitting Parts

- The cylinder block is made of an aluminum alloy to realize a dramatic weight reduction. Furthermore, it has been made compact in terms of both overall length and width as follows: a 60° V6 bank angle, a 36.6mm bank offset, and a 105.5mm bore center distance.
- The oil pan consists of a two-piece construction. Oil pan No. 1 is made of an aluminum alloy, and oil pan No. 2 is made of stamped steel

sheet. Oil pan No. 1 has built-in stiffeners that tighten the cylinder block and the transaxle case together. This increases the rigidity of the entire power plant, resulting in reduced vibration and weight reduction.

- Appropriate ribs are placed on the outer wall of the cylinder block to increase rigidity.
- An FIPG (Formed-In-Place Gasket), which excels in sealing performance, is used on the mating surfaces of the oil pan.

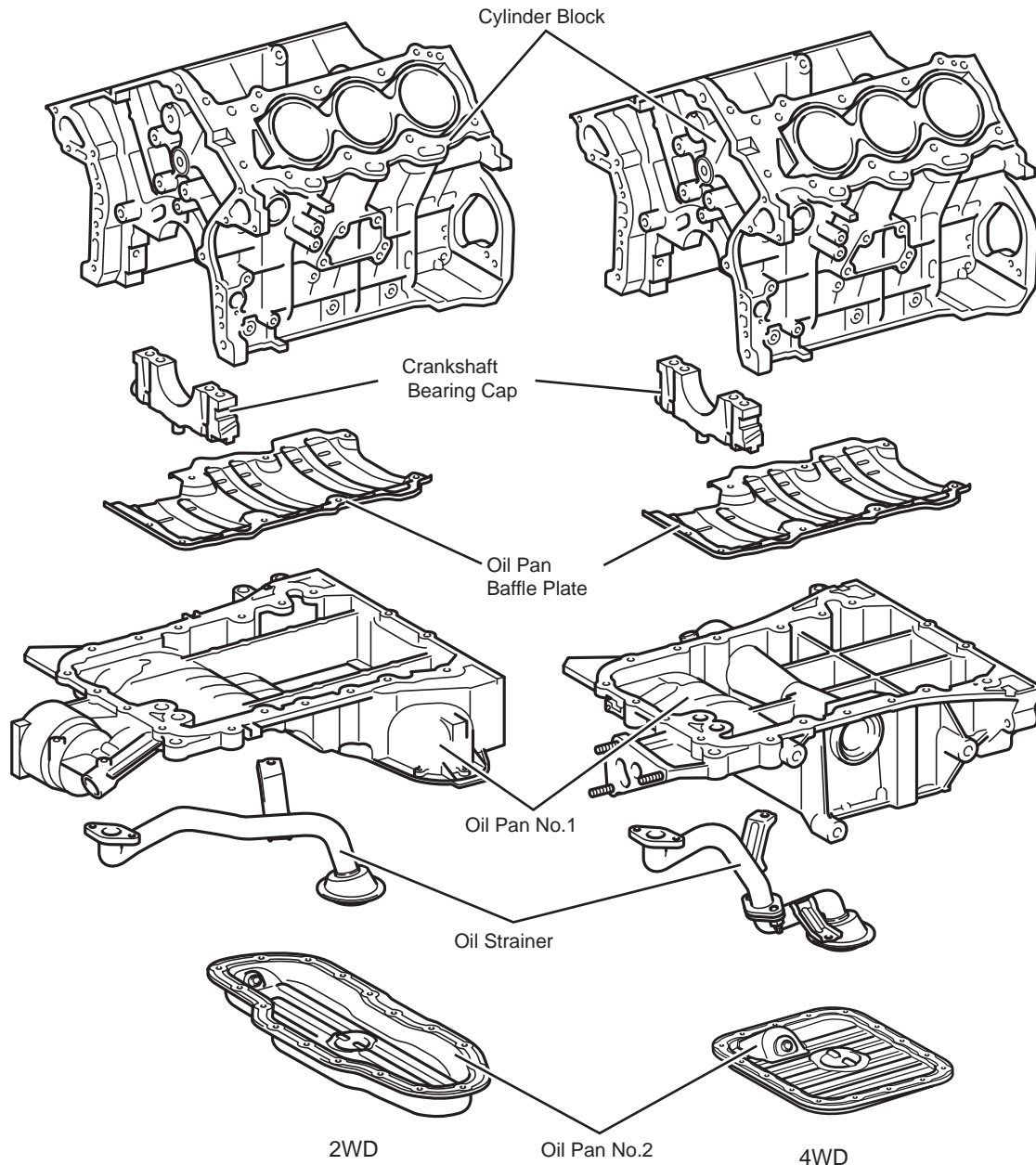

A4270060P

## Cylinder Block

- The cylinder liner is a centrifugal cast iron liner insert. Its outer spiny surface enhances contact with the aluminum block, thus improving heat dissipation. This lowers the temperature of the piston and suppresses the deformation of the bore.
- The outer walls of the block are curved and reinforcement ribs are provided on the end of the block that is coupled to the transmission in order to attain a high level of rigidity.
- The oil return holes from the cylinder heads and the blowby gas passages have been optimally arranged to ensure the smooth return of oil

and heighten the rigidity of the side faces of the cylinder block.

- Drilled coolant passages are provided between the bores in order to positively cool the upper areas of the cylinder bores, which are easily affected by heat. Thus, a more uniform temperature distribution has been achieved in the circumferential direction of the bore wall surface. This improves knocking resistance and minimizes the heat deformation that occurs between the cylinder bores. Thus, an engine with low friction, high performance, and enhanced fuel economy has been achieved.
- A knock sensor is provided on both the right and left sides of the V bank, enabling optimal knock control.
- The crankshaft bearing caps are made of cast iron, and each is tightened with 4 bolts from the bottom, using the plastic region tightening method. Also, each bearing cap is tightened from both sides together with the cylinder block, which increases rigidity and decreases vibration and noise.

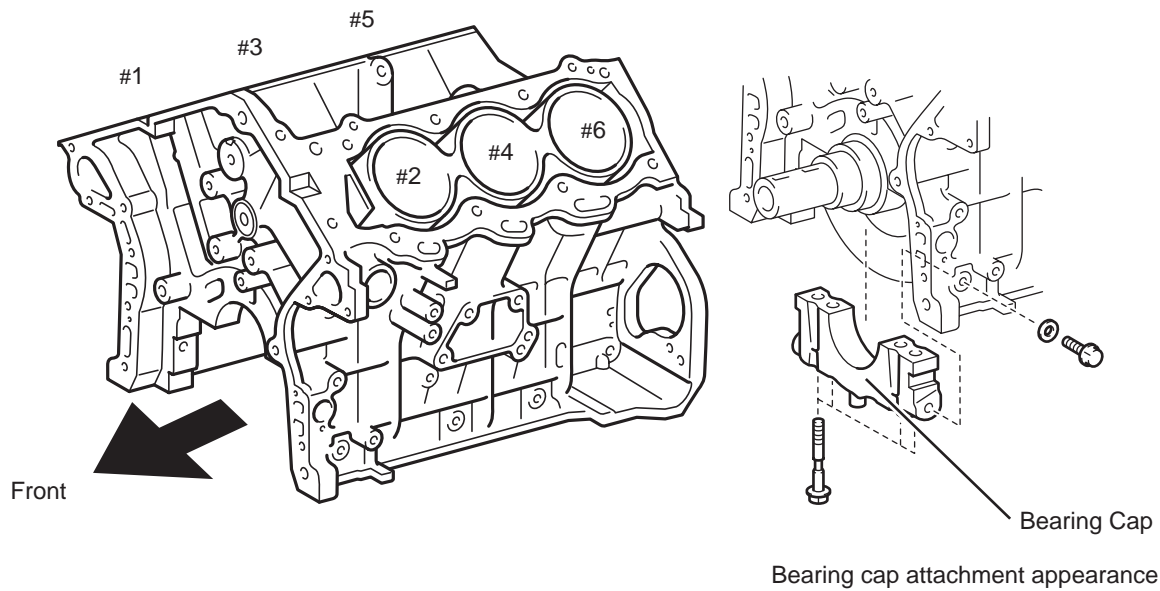

A4270061P

Cylinder Block

Overall Length	[mm (in.)]	402.1 (15.831)
Overall Width	[mm (in.)]	408.0 (16.063)
Overall Height	[mm (in.)]	320.2 (12.606)
Bore Diameter	[mm (in.)]	87.5 (3.445)
Bore Center Distance	[mm (in.)]	105.5 (4.154)
Bank Offset	[mm (in.)]	36.6 (1.441)

## Water Jacket Spacer

- A water jacket spacer made of plastic, which excels in heat resistance and forming precision, is provided in the water jacket of the cylinder block. This optimizes heat distribution along the cylinder bore wall and reduces friction.

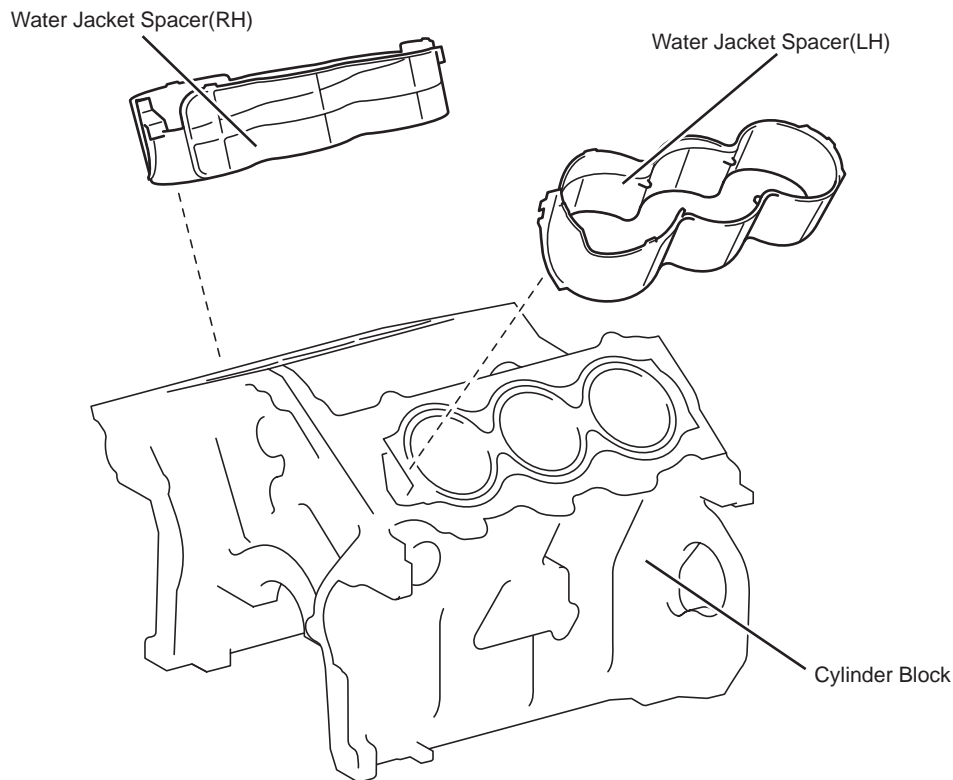

A4270062P

## Function of Water Jacket Spacer

The water jacket spacer suppresses the water flow in the center of the water jacket. This increases the flow speed of the coolant along the upper part of the cylinder bore, thus improving the cooling of the upper area of the cylinder block and between the cylinder bores. Furthermore, the area near the center of the cylinder bore becomes less susceptible to the influences of the coolant, allowing the temperature along the wall surface to rise. These measures decrease the temperature differences along the surface of the cylinder bore wall and enable uniform thermal expansion. In addition, these measures lower the viscosity of the engine oil that adheres to the surface of the bore wall, thus reducing friction.

## Timing Chain

- The timing mechanism is a chain-driven system that is maintenance-free. Both the primary and secondary timing chains consist of 9.525mm(0.375in.) pitch, high-strength, single-row roller chains and compact sprockets, which contribute to making the engine compact.
- A two-stage chain system is used. It consists of a primary chain that enables the crankshaft to drive the right and left intake camshafts, and a secondary chain that enables the intake camshafts to drive the exhaust camshafts.
- The primary chain uses a check ball type chain tensioner with a ratchet mechanism that uses both engine oil pressure and a spring force. The secondary chain uses a compact tensioner that directly pushes on the chain by using engine oil pressure and a spring force. These tensioners constantly apply optimal tension to the timing chains in order to ensure a quiet and reliable operation.
- The timing chain cover is made of an aluminum alloy that is lightweight and excels in sound insulation capability. The one-piece cover seals the front of the cylinder block, camshaft housing, and cylinder head. The crankshaft sprocket is provided with a guide that prevents the chain links from jumping. This prevents the chain from being installed incorrectly during maintenance, as a result of the chain falling out. A service hole for the primary chain tensioner is provided in the timing chain cover to facilitate maintenance.
- The chain dampers and the tensioner shoes are made of a plastic material that excels in wear resistance.

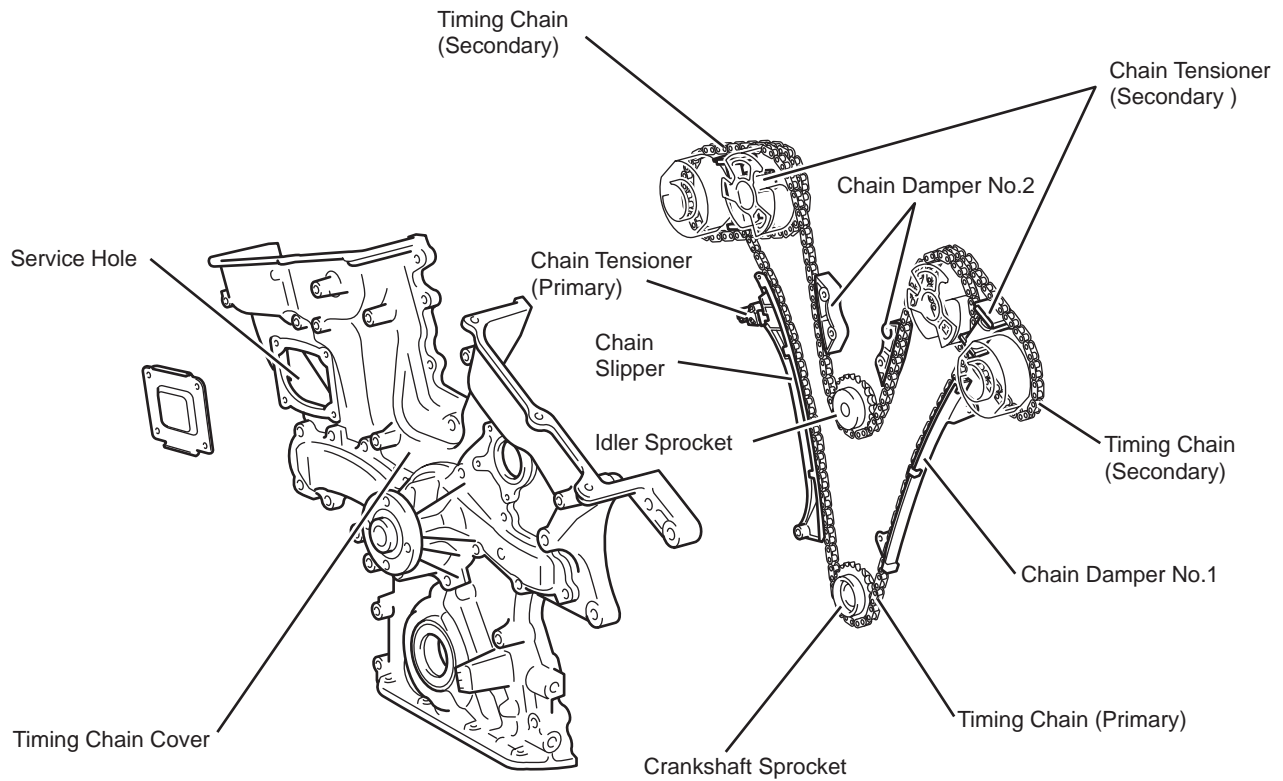

A4270063P

#### Sprocket

	Number of Teeth
Crankshaft Sprocket	18
Idler Sprocket	18
Camshaft Sprocket (Primary)	36
Camshaft Sprocket (Secondary: IN)	24
Camshaft Sprocket (Secondary: EX)	24

#### Timing Chain

	Number of Links
Timing Chain (Primary)	170
Timing Chain (Secondary)	46

## Valve Mechanism

- A Dual VVT-i (Dual Variable Valve Timing-intelligent : continuously variable intake and exhaust valve timing mechanism) system is used to control the intake camshaft and the exhaust camshaft to an optimal valve timing in accordance with the driving conditions.
- The camshafts are made of alloyed cast iron. Their cams are induction hardened and their surfaces are finished with a higher precision to

improve wear resistance and reduce friction.

- Roller rocker arms are used in the valve train in order to dramatically reduce friction between the cams and the sliding surfaces to improve fuel economy. In addition, hydraulic lash adjusters are used, making valve clearance adjustments unnecessary and facilitating service.
- Along with the use of the roller rocker arms, the cam profile has been shaped with recessed radii. This increases the amount of valve lift near the beginning of the opening of the valve and near the end of the closing of the valve, in order to further increase power output.

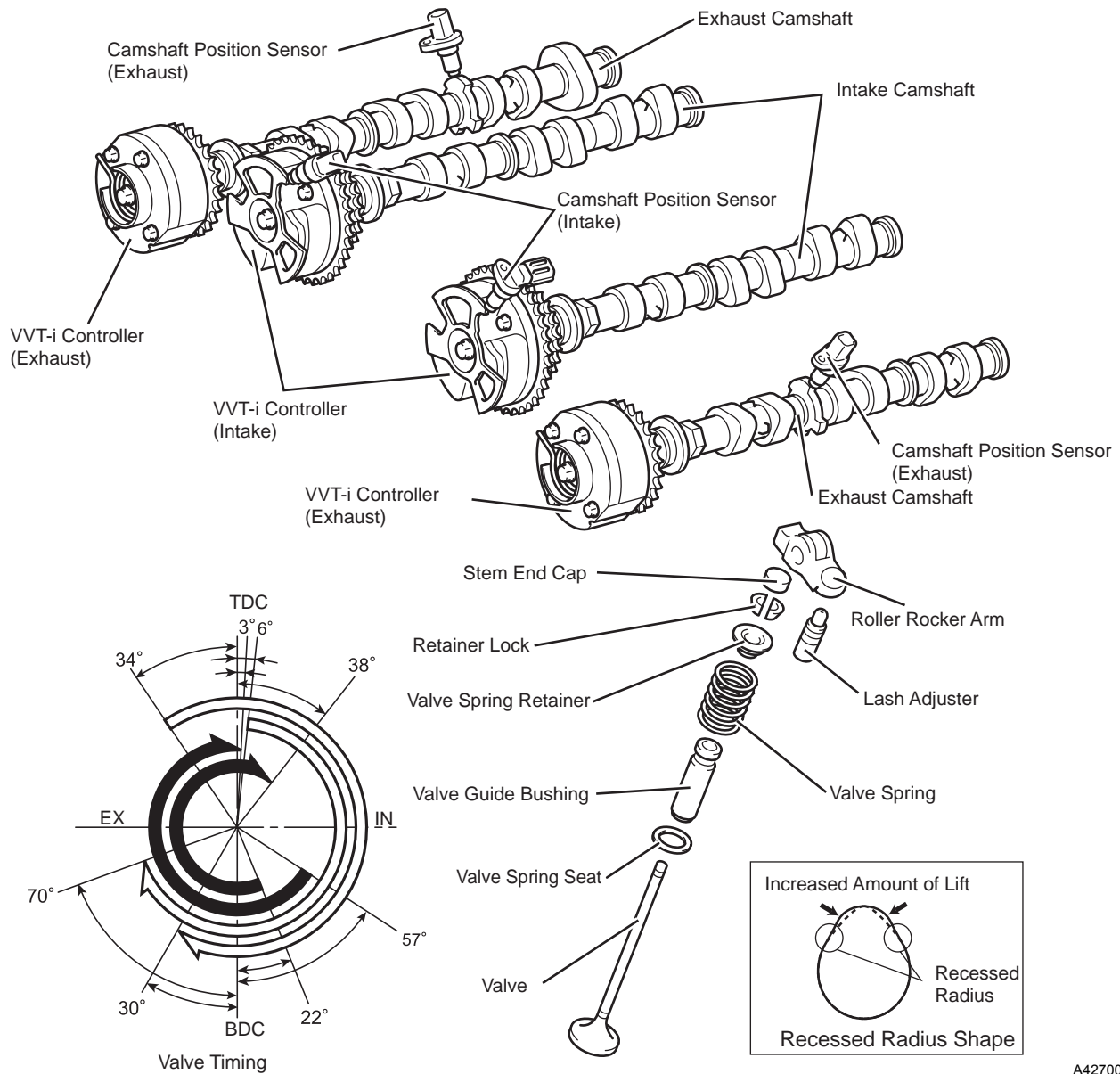

A4270064P

Camshaft

	Intake	Exhaust
Cam Lift Amount [mm (in.)]	5.99 (0.236)	6.14 (0.242)
Cam Lobe Width [mm (in.)]	15.35 (0.604)	14.1 (0.555)



Valve

	Intake	Exhaust
Overall Length [mm (in.)]	105.65 (4.159)	111.5 (4.390)
Face Diameter [mm (in.)]	34.5 (1.358)	29.0 (1.142)
Stem Diameter [mm (in.)]	5.5 (0.216)	←

Valve Spring

Wire Diameter [mm (in.)]	3.3 (0.130)
Coil Inner Diamet [mm (in.)]	18.0±0.2 (0.709±0.08)
Free Length [mm (in.)]	46.51 (1.831)

## Roller Rocker Arm

- The rocker arm is made compact and lightweight with a stamped steel arm with built-in needle bearings. The roller is supported by needle roller bearings that dramatically reduce friction at the sliding area, which contributes to fuel economy.
- An oil delivery pipe system is used for supplying oil to the roller rocker arms. This system positively supplies oil from above the camshaft to the lubrication area to ensure reliability.

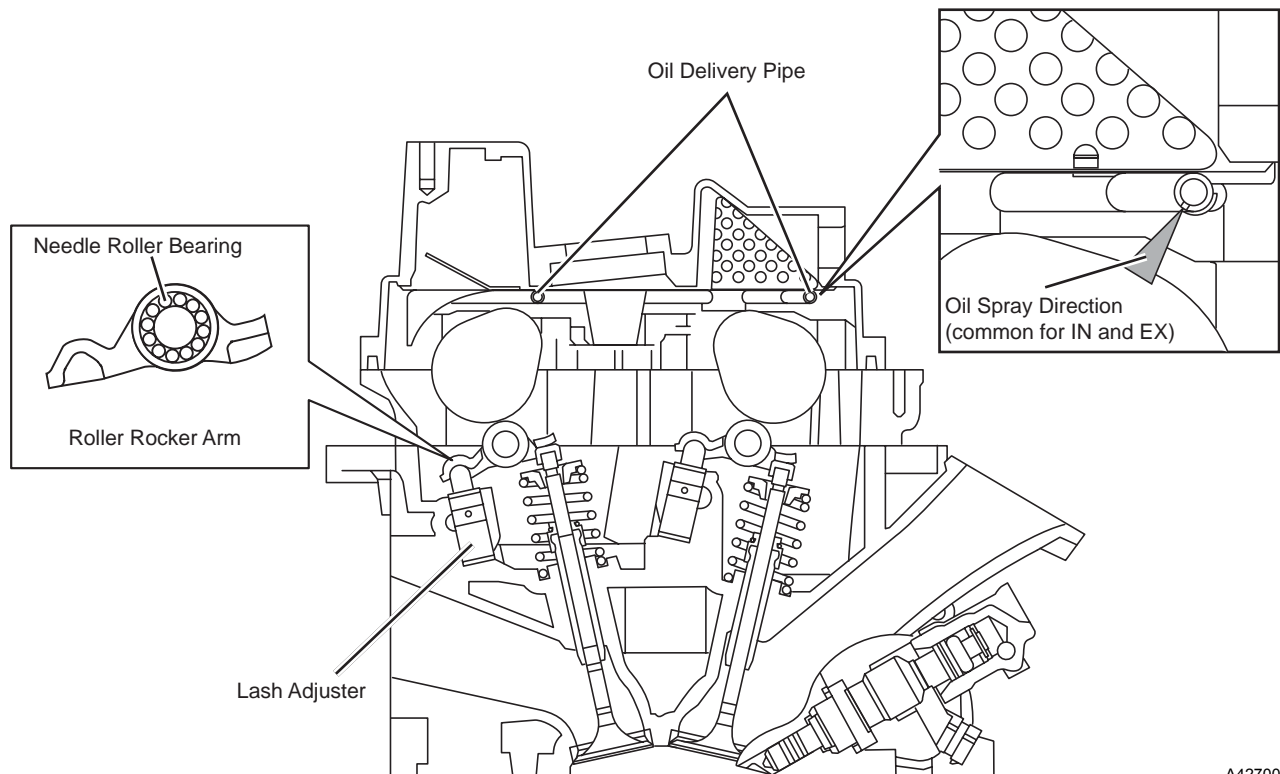

A4270065P

## Lash Adjuster

### Lash Adjuster Construction

- Compact, hydraulic lash adjusters are used to constantly eliminate the gap (clearance) between the cams and rocker arms, thus enhancing the quiet performance of the engine.
- The lash adjuster is placed at the fulcrum of the rocker arm at the opposite end of the valve, and uses the oil that is supplied by the cylinder

head as the operating fluid. The plunger in the lash adjuster body slides vertically due to the repulsion of the plunger spring or the hydraulic force in order to adjust the clearance.

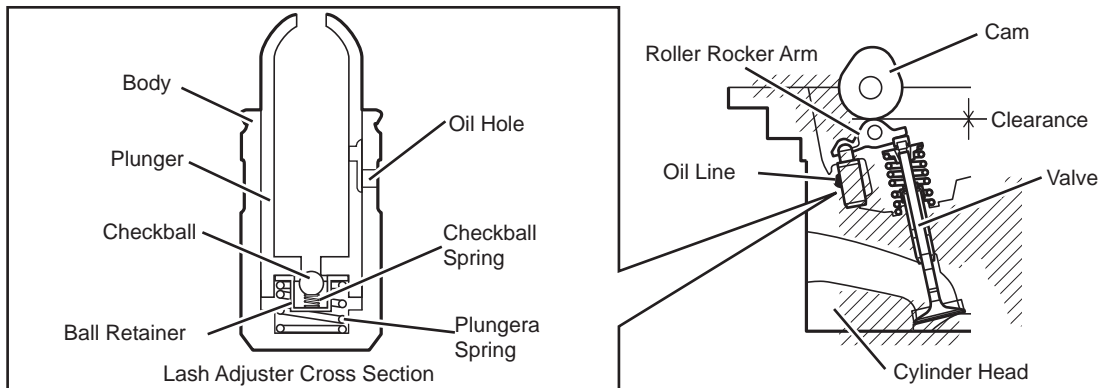

A4270066P

### Lash Adjuster Operation

- The camshaft rotates clockwise, causing the cam to push on the rocker arm (acting), and a load is applied to both the valve and the plunger. At this time, the plunger almost gets pushed in, but because the check ball closes, the plunger stops. This allows the rocker arm to tilt in the clockwise direction, using the top of the plunger as the fulcrum, thus pushing the valve down.
- When the cam gets past the apex, the force of the valve spring causes the rocker arm to start ascending. However, because the force of the valve spring also acts on the lash adjuster, the high pressure chamber maintains its hydraulic pressure.
- When the valve closes (action ended), the oil in the high-pressure chamber is released from the pressurized state. At this time, a valve clearance is about to be created. However, the force of the plunger spring causes the plunger to push the rocker arm upward in order to maintain a constant zero valve clearance. At the same time, the capacity of the high-pressure chamber increases, creating a pressure difference between the high-pressure and low-pressure chambers. When this pressure difference becomes greater than the force of the check ball spring, the check ball moves downward to provide an oil passage. This allows the oil to flow from the low-pressure chamber to the high-pressure chamber in preparation for the next movement (standby state).

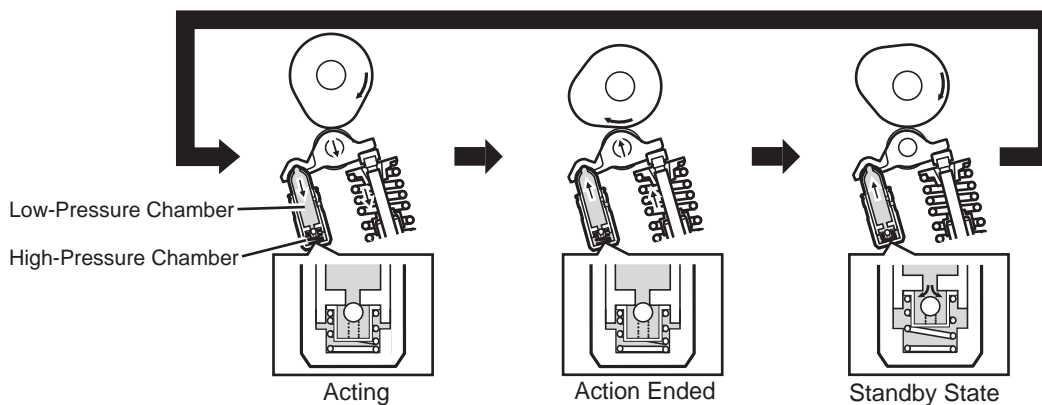

A4270067P

### Dual VVT-i Controller

- The VVT-i controller is a vane type that has low friction and is highly efficient while it is being driven.
- The VVT-i controller for the intake is a 3-vane type, and a 4-vane type for the exhaust. When the engine is stopped, a lock pin locks the vanes for the intake in the most retarded position and the vanes for the exhaust in the most advanced position.
- The VVT-i for the exhaust is provided with an advance assist spring that provides a torque assist in the advance direction so that the lock

pin engages securely when the engine is stopped.

- Based on the signals provided by the sensors, the ECM controls the hydraulic pressure that acts on the advance chamber and retard chamber in the VVT-i controller, via an OCV (Oil Control Valve) that is mounted on the cylinder head cover. Thus, it continuously varies the phases of the intake and exhaust camshafts.

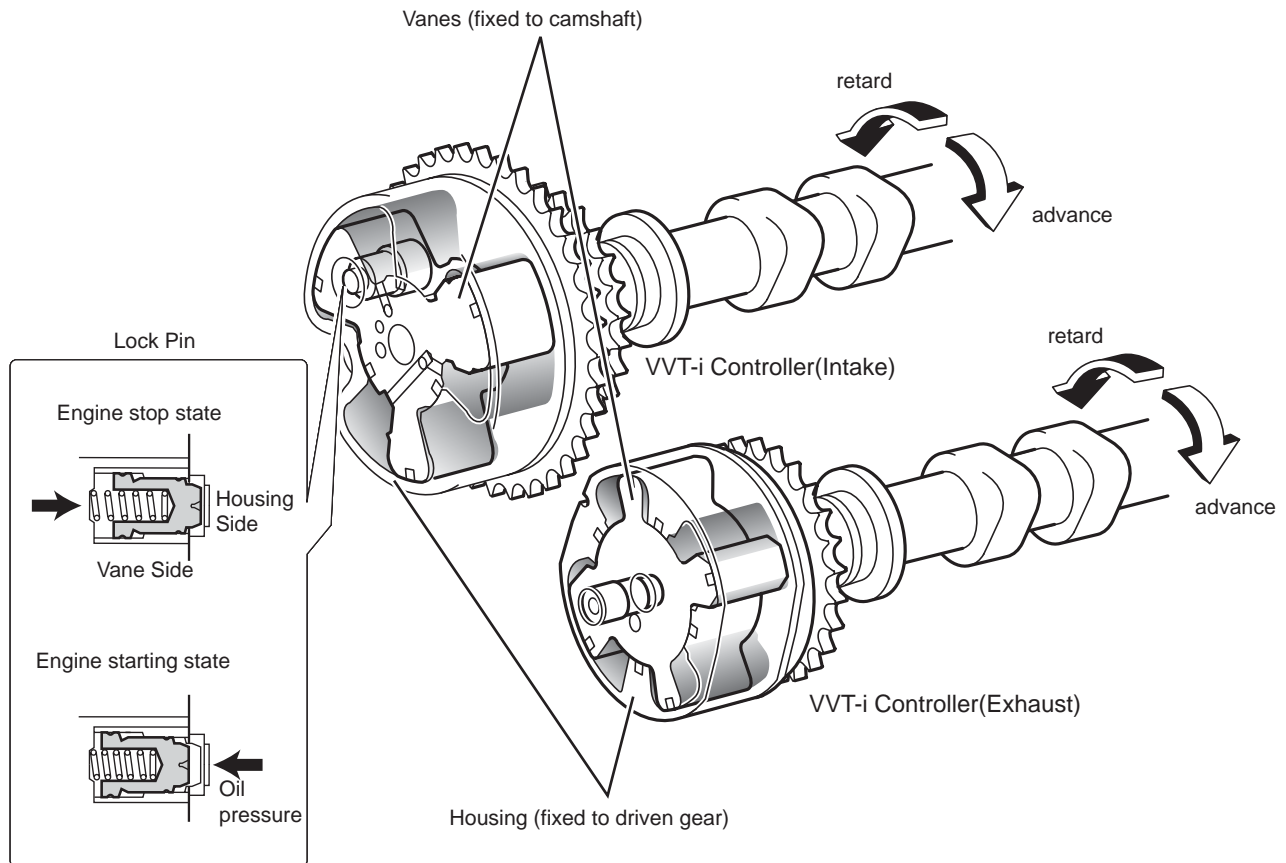

\*The drawing shows the VVT-i controller for the intake in the retarded state and the VVT-i controller for the exhaust in the advanced state.

A4270068P

### Effects of Dual VVT-i

- By advancing and retarding the intake and exhaust valves, the Dual VVT-i provides the following effects.

Low temperature operation  
Starting the engine  
Running at idle  
Light load operation

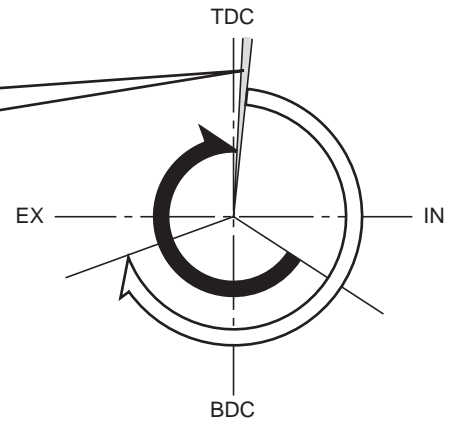
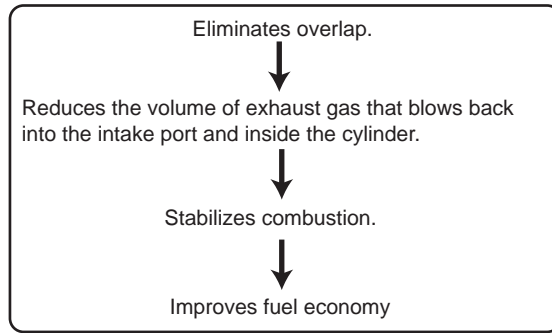

Medium load range

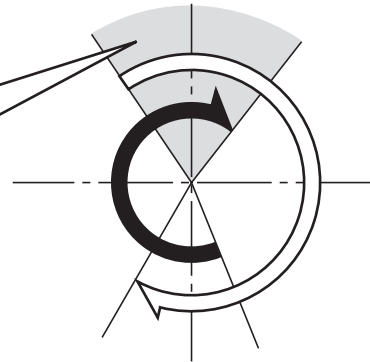
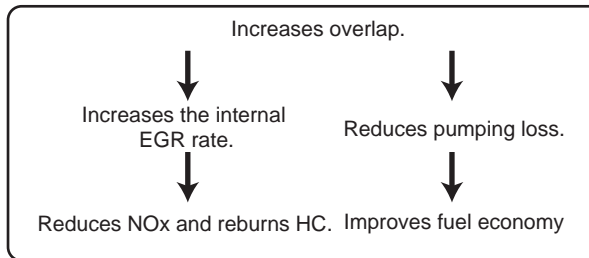

High load range, low- to medium-speed

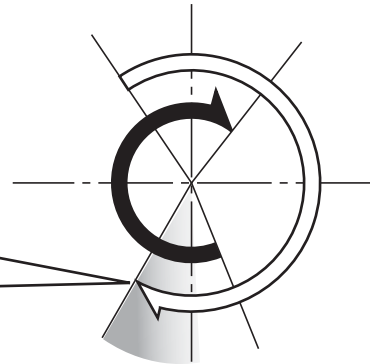
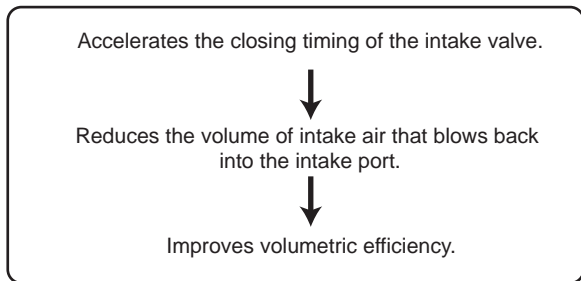

High load range, high speed

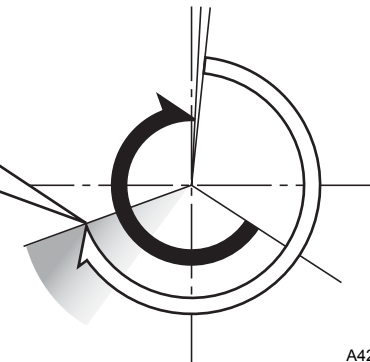
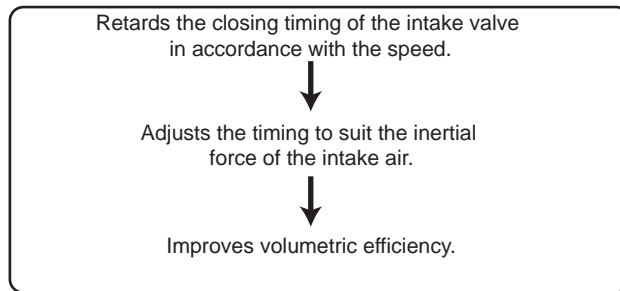

A4270069P

### Camshaft Timing Oil Control Valve

- In accordance with the duty cycle signals received from the ECM, this OCV controls the position of the spool valve in order to constantly

achieve optimal valve timing. When the engine is stopped, the force of a spring keeps the intake side of the spool valve in the most retarded state, and the exhaust side to the most advanced state, in order to ready the valves for the subsequent starting.

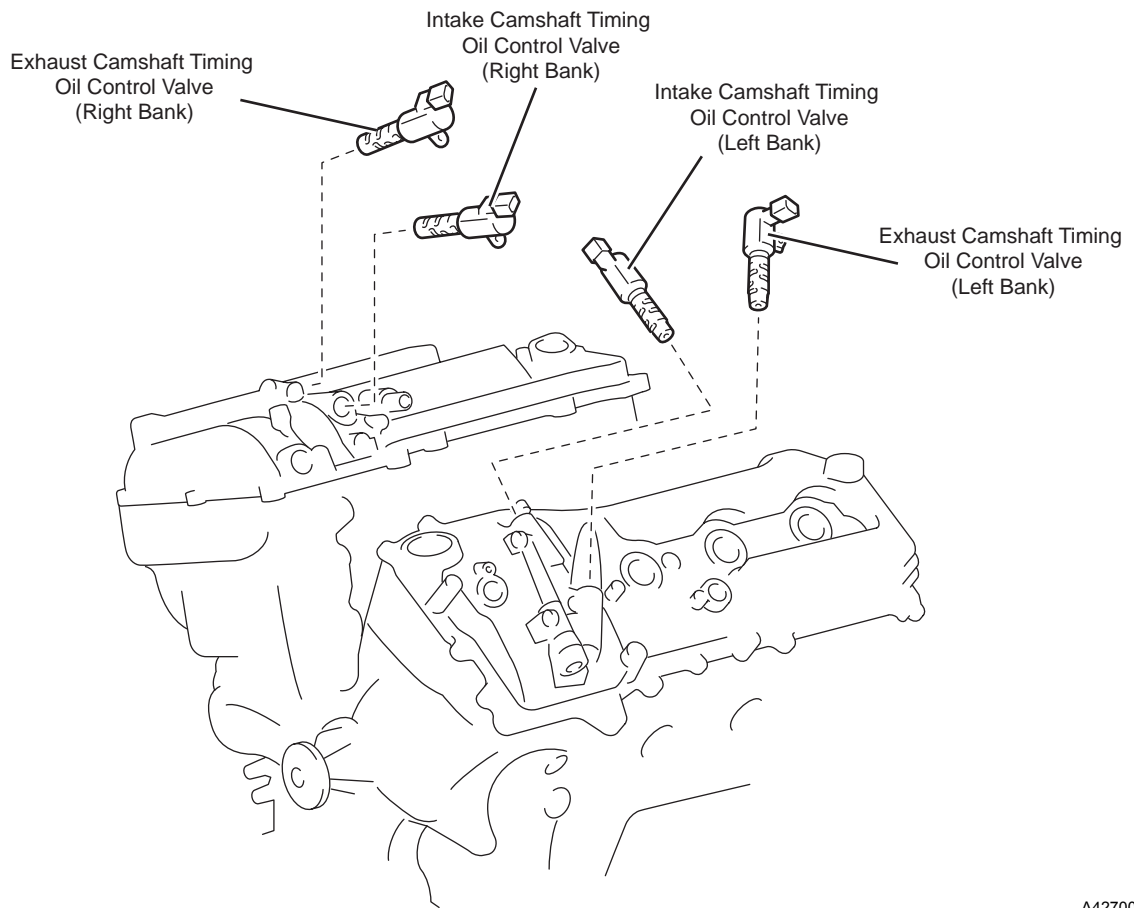
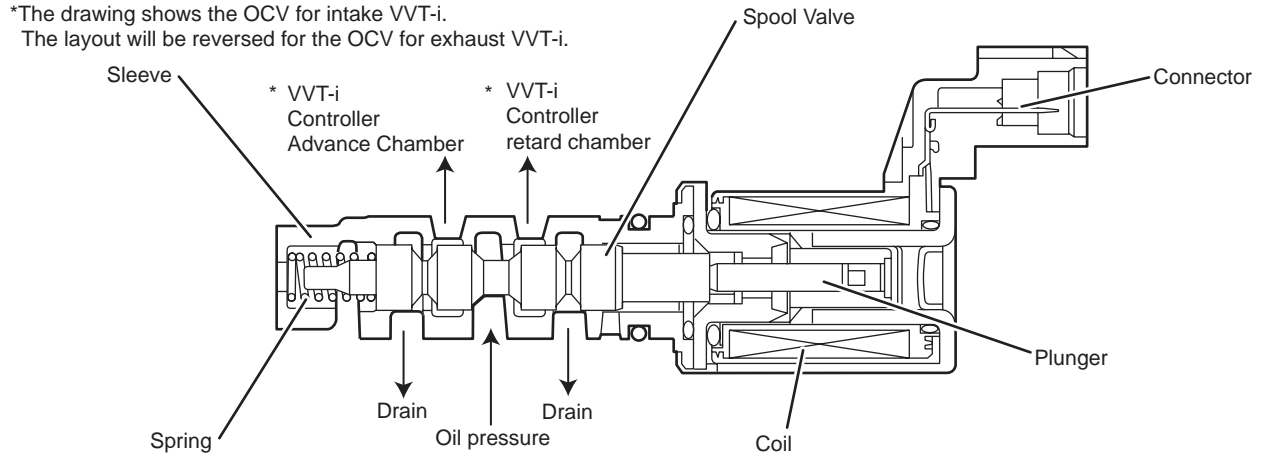

A4270029P

## Dual VVT-i Operation

- The Dual VVT-i controls the advance, retard, and holding states as illustrated below, in accordance with the driving conditions.

Outline of Intake VVT-i Operation

The spool valve of the OCV reaches the position shown in the drawing, as a result of receiving a signal from the ECM. Then, hydraulic pressure is applied to the hydraulic pressure chamber for advance, causing the intake camshaft to rotate towards advance.

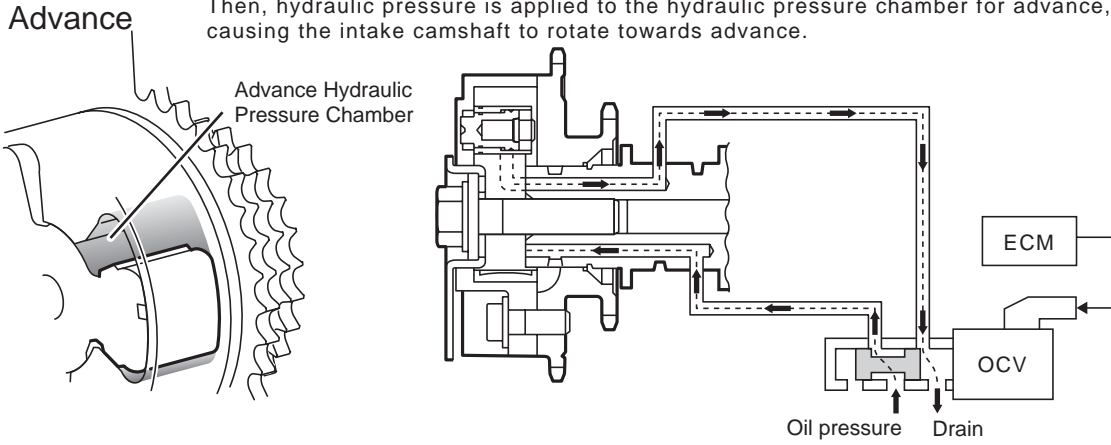

The spool valve of the OCV reaches the position shown in the drawing, as a result of receiving a signal from the ECM. Then, hydraulic pressure is applied to the hydraulic pressure chamber for retard, causing the intake camshaft to rotate towards retard.

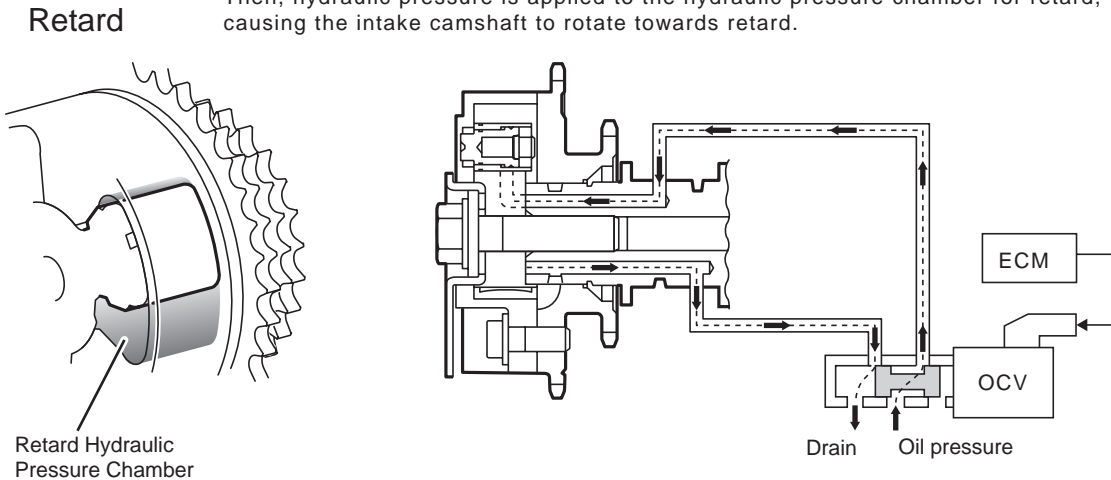

The ECM effects control by calculating the target degree of advance in accordance with the driving conditions. After reaching the target timing, the ECM maintains the timing by setting the OCV to neutral, provided that the driving conditions do not change. As a result, the valve timing can be set to any target position.

Hold

At the same time, the engine oil is prevented from flowing out needlessly.

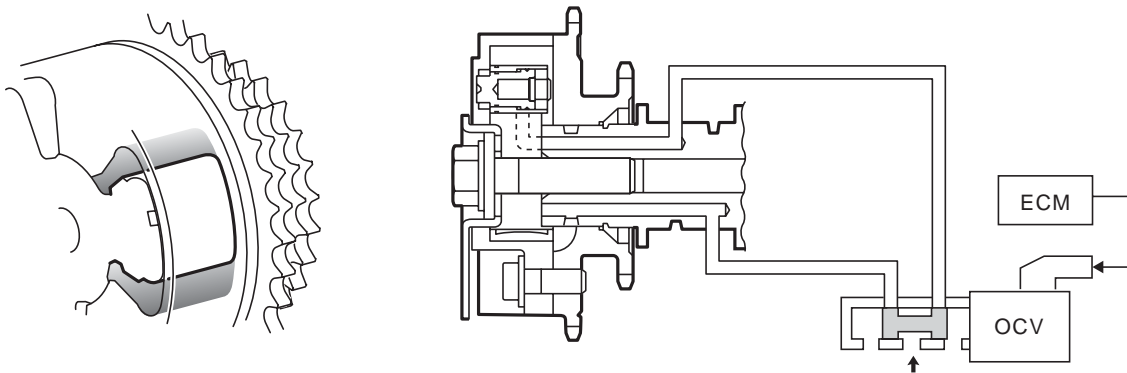

## Outline of Exhaust VVT-i Operation

### Advance

The spool valve of the OCV reaches the position shown in the drawing, as a result of receiving a signal from the ECM. Then, hydraulic pressure is applied to the hydraulic pressure chamber for advance, causing the exhaust camshaft to rotate towards advance.

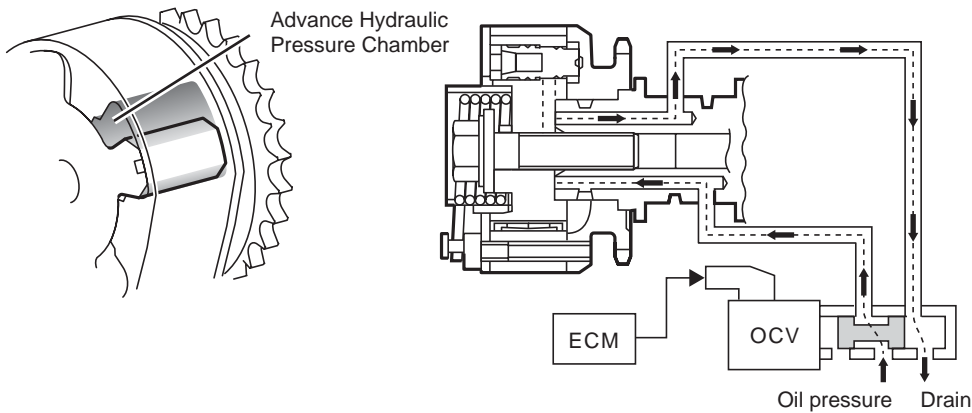

### Retard

The spool valve of the OCV reaches the position shown in the drawing, as a result of receiving a signal from the ECM. Then, hydraulic pressure is applied to the hydraulic pressure chamber for retard, causing the exhaust camshaft to rotate towards retard.

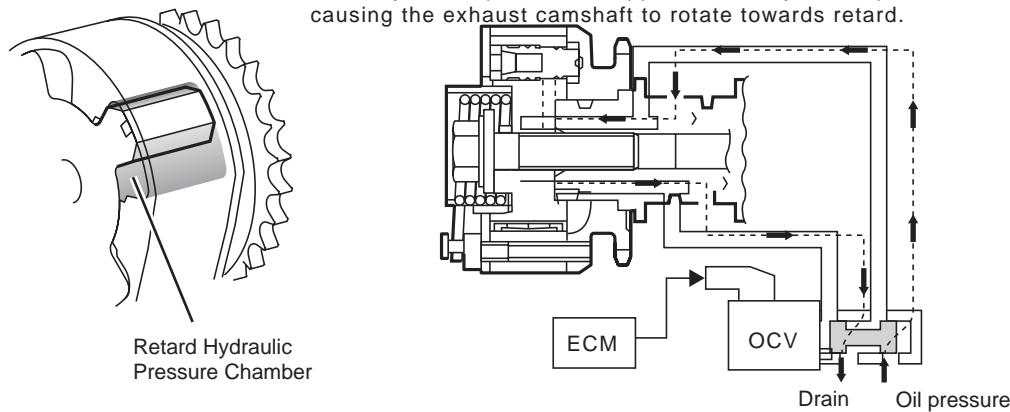

The ECM effects control by calculating the target degree of advance in accordance with the driving conditions. After reaching the target timing, the ECM maintains the timing by setting the OCV to neutral, provided that the driving conditions do not change. As a result, the valve timing can be set to any target position. At the same time, the engine oil is prevented from flowing out needlessly.

### Hold

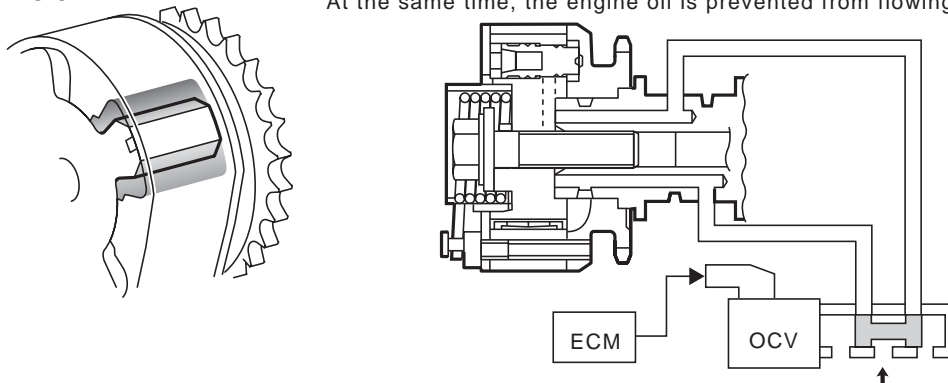

## Piston and Crankshaft

- The pistons are made of a lightweight and highly rigid aluminum alloy.

- The connecting rods are made of highly rigid, sintered forged steel that ensures a high level of reliability.
- The crankshaft, which is made of forged steel, is a type that has 4 journals and 5 balance weights. It is lightweight and the balance weights are placed optimally to reduce vibration and noise. The crank pin width and the journal fillet have been made narrower to shorten the length of the crankshaft, in order to realize both high rigidity and low friction. The fillets have been induction hardened to ensure ample strength.
- The connecting rod bearings and the crankshaft bearings have been made narrower to reduce friction. The bearing lining is made of an aluminum alloy to realize both wear resistance and seizure resistance.
- The crankshaft pulley is provided with a torsional damper to reduce vibration and noise.

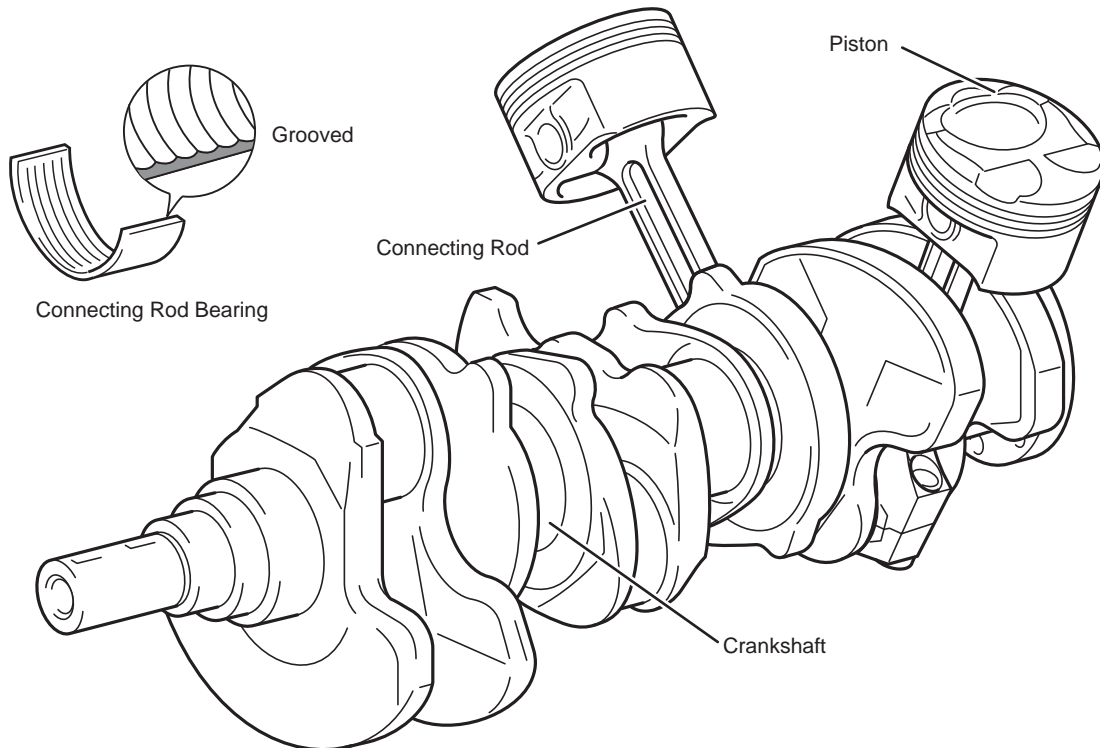

A4270152P

#### Connecting Rod

Big End Inner Diameter	[mm (in.)]	56.0 (2.205)
Small End Inner Diameter	[mm (in.)]	22.0 (0.866)
Center Distance Between Big and Small Ends	[mm (in.)]	147.5 (5.807)

#### Crankshaft

Journal Diameter	[mm (in.)]	61.0 (2.402)
Crank Pin Diameter	[mm (in.)]	53.0 (2.087)
Crank Pin Stroke Radius	[mm (in.)]	41.5 (1.634)

## Piston

- The pistons have been made lightweight with a short compression height and a short skirt. The piston skirt has a streak finish and a plastic coating that excel in seizure resistance, in order to reduce noise and friction.
- A compact combustion chamber is provided on top of the piston to realize stable combustion. Together with the pentroof type combustion



chamber on the cylinder head, this realizes a high compression ratio, resulting in both high performance and fuel economy.

- Each piston ring is made thinner and with low tension to reduce friction.

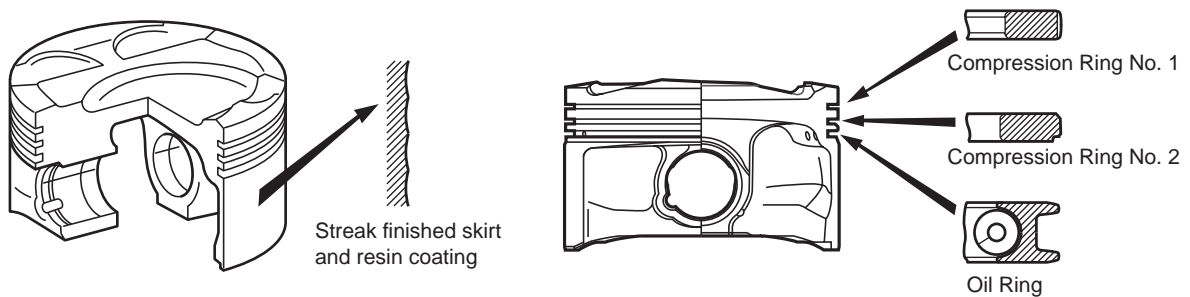

A4270070P

#### Piston

Basic Diameter	[mm (in.)]	87.465 (3.444)
Pin Hole Offset	[mm (in.)]	0.5 (0.020)
Compression Height	[mm (in.)]	31.05 (1.222)

#### Piston Pin

Outer Diameter	[mm (in.)]	22.0 (0.866)
Inner Diameter	[mm (in.)]	12.7 (0.5)
Length	[mm (in.)]	56.0 (2.205)

#### Piston Ring

	Compression Ring No. 1	Compression Ring No. 2	Oil Ring
Material	Stainless Steel	Steel	Steel
Shape	Barrel Face	Tapered Face + Undercut	Combination
Width [mm (in.)]	1.2 (0.047)	1.2 (0.047)	2.0 (0.079)
Thickness[mm (in.)]	2.7 (0.106)	2.7 (0.106)	2.75 (0.108)
Surface Treatment	PVD (Physical Vapor Deposition) (Periphery)	Anti-Corrosion	Gas Nitriding

## Serpentine Belt Drive System

- A serpentine drive system, which uses a single V-ribbed belt to drive all accessories, is used in order to shorten the overall length of the engine and make it lightweight.
- An auto tensioner is used for the V-ribbed belt to ensure the long life of the belt and accessories, make them maintenance free, and improve serviceability by facilitating the removal and reinstallation of the belt.

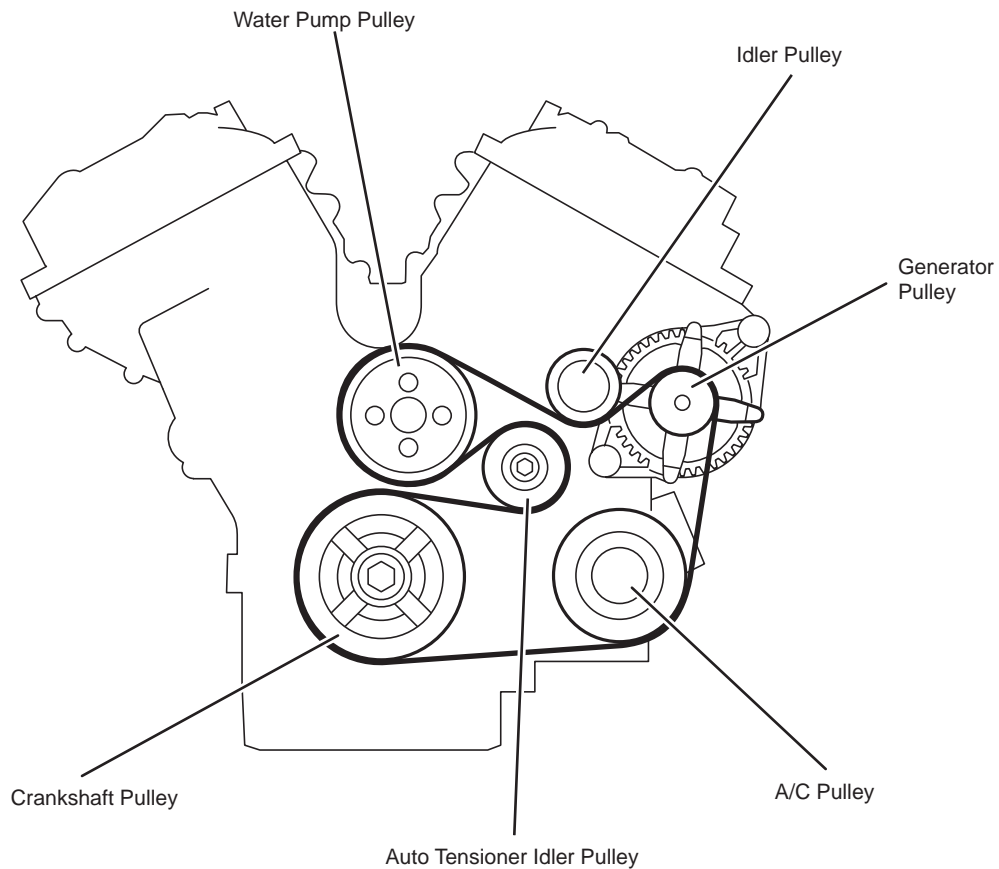

A4270071P

Pulley Specifications

	Pulley Diameter [mm (in.)]
Crankshaft Pulley	140 (5.512)
Auto Tensioner Idler Pulley	70 (2.756)(driven from back face)
A/C Pulley	115(4.528)
Idler Pulley	70 (2.756)(driven from back face)
Water Pump Pulley	120 (4.724)
Generator Pulley	52.5 (2.067)

V Ribbed Belt Specifications

Width [mm]	24.92 (0.981)
Length [mm]	1550 (61.024)
Number of Ribs	7

**Blowby Gas Reduction System**

- A PCV hose and a PCV valve are provided to forcefully feed the blowby gas into the intake system for combustion, in order to prevent the blowby gas, which includes a large amount of HC, from being discharged into the atmosphere. A new air circulating system is used wherein

fresh air from the air cleaner hose is introduced via the right bank head cover and the blowby gas is discharged into the surge tank via the left bank head cover.

- Under light load conditions, the intake manifold vacuum causes the blowby gas to be drawn via the PCV valve into the intake manifold, to be combusted. The internal pressure is regulated in the crankcase, where fresh air is introduced from the cylinder head cover.
- Under high load conditions, the intake manifold vacuum forcefully introduces the blowby gas into the intake system, where it is combusted. This prevents the blowby gas, which contains a large amount of HC, from being released to the atmosphere.
- A dedicated oil return passage and a blowby gas passage are provided in the cylinder block and the cylinder head to enhance the oil return function and minimize the volume of oil that is taken away.

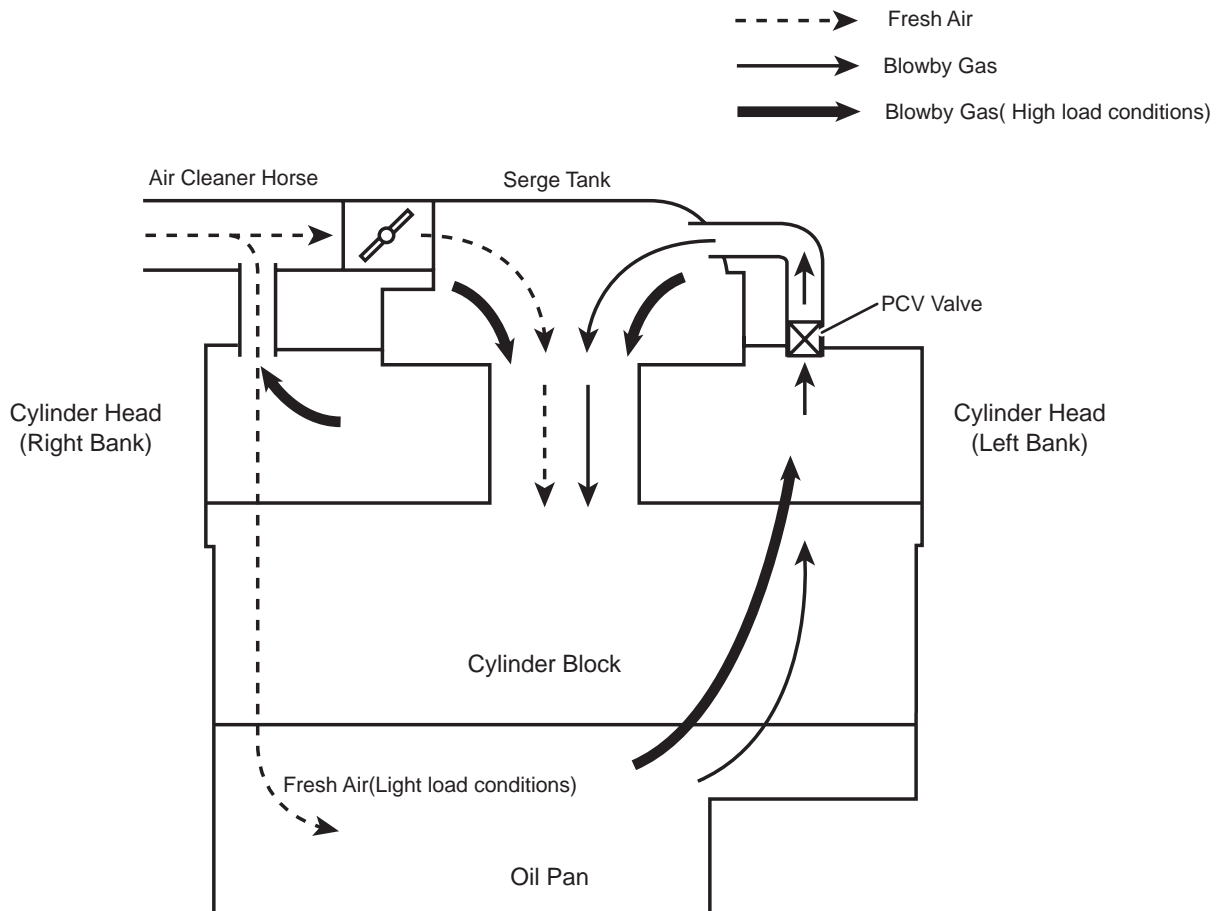

Conceptual operation image of the blowby reduction system

A4270072P

## Engine Mounts

- The front engine mounts are installed on the upper area of the cylinder block where the vibration is minimal. In addition, the brackets have been angled more moderately to reduce vibration and noise in all operating ranges. The brackets are made of cone-shaped aluminum alloys to reduce weight, vibration, and noise.
- The front engine mount uses a liquid-filled double-orifice mount insulator to reduce vibration and noise in the operating range of the engine. On the 4WD model, the mount is shaped elliptically to save space for the installation surface.
- The die shape for the rear engine mount has been optimized to reduce vibration in the operating range.

