

SUSPENSION AND AXLE

■ SUSPENSION

1. General

- A double-wishbone type suspension is used in the front.
- A multi-link type suspension is used in the rear.

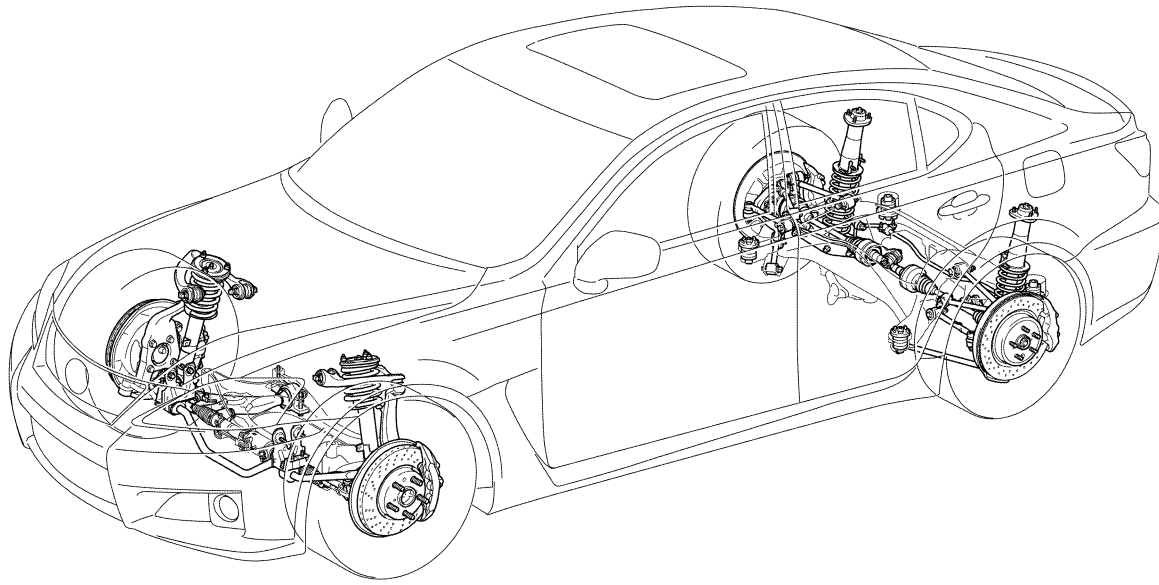

08D0CH111Z

► Specifications ◀

Front Suspension Type		Double-wishbone
Front Wheel Alignment	Tread*	mm (in.)
	Caster*	
	Camber*	
	Toe-in*	mm (in.)
	King Pin Inclination*	
Rear Suspension Type		Multi-link
Rear Wheel Alignment	Tread*	mm (in.)
	Camber*	
	Toe-in*	mm (in.)

*: Unloaded Vehicle

2. Front Suspension

General

- High-mounted front suspension upper arms are used for the double-wishbone type suspension.
- High-rate front coil springs are used to reduce roll when cornering and reduce nose-dive when braking.
- The adoption of large-diameter front stabilizer bars increases roll rigidity and optimizes roll posture.
- The adoption of high strength, lightweight forged aluminum steering knuckles reduces unsprung mass.
- The steering gear is placed forward of the axle. During cornering, this changes the steering angle to toe-out in accordance with the lateral force. As a result, a smoother response has been realized during high-speed driving.
- The suspension components are optimally allocated to increase the steering angle of the wheels. As a result, the minimum turning radius is reduced and excellent maneuverability is realized.

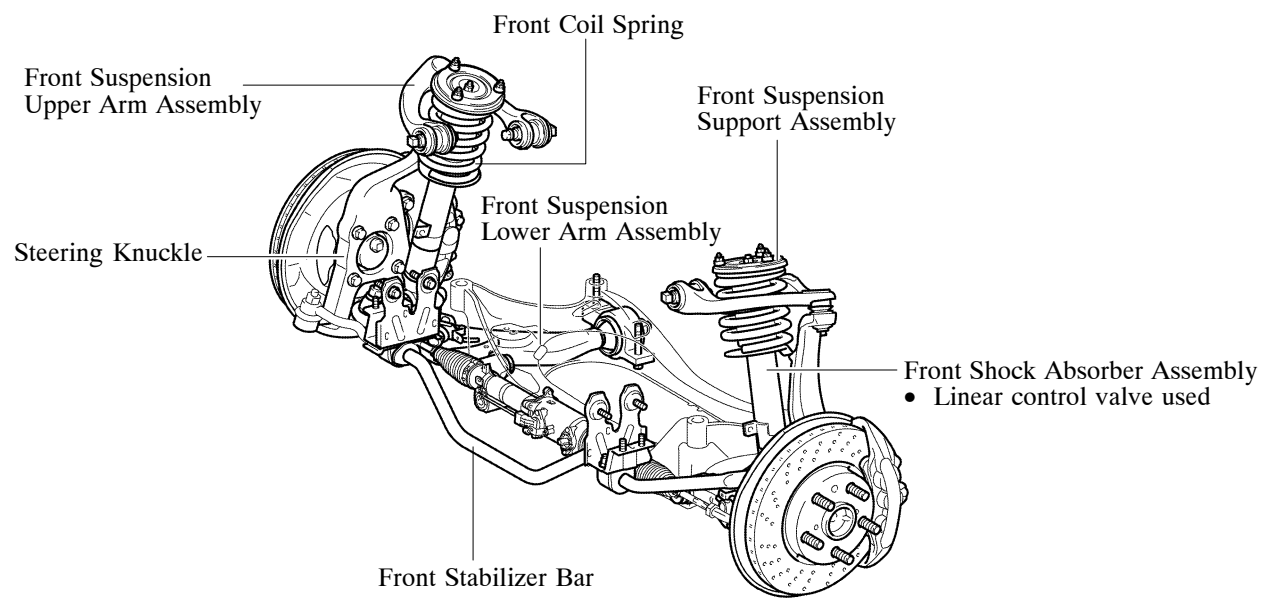

Optimized Roll Center

When roll is occurring, a difference in the change in the height of the center of gravity is created geometrically depending on the setting of the roll center height and its rate of change. For this reason, the arms have been placed appropriately to achieve an optimal setting. As a result, the height of the center of gravity is kept low and excellent roll posture is ensured.

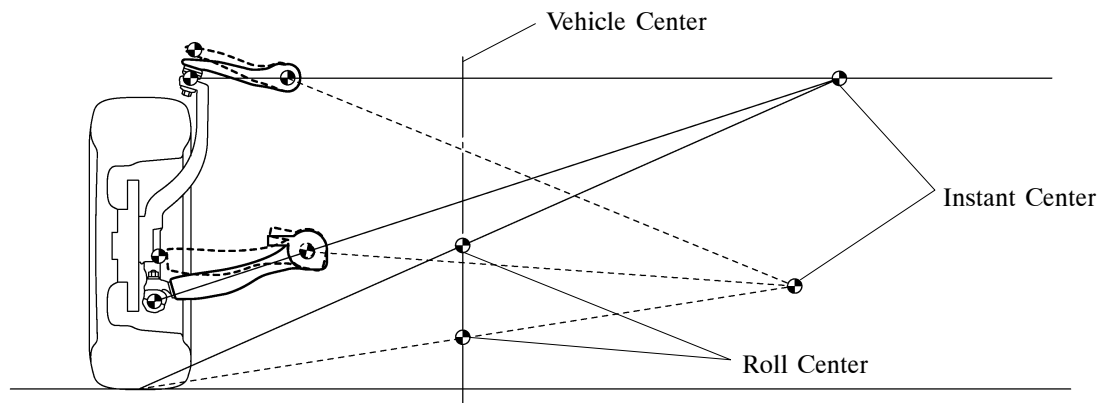

281CH17

Braking Understeer Characteristics

- During braking, the load of the vehicle moves to the front wheels. If the direction of the wheels during a turn is constant, the tire will exhibit the behavior of rolling inward of the turn, due to the nature of the forces on the wheels. To gain the appropriate understeer (thus reducing the steering angle of the wheels) during braking, the suspension components have been appropriately allocated so that the wheels will change to toe out during braking.
- This ensures the proper stability and longitudinal compliance, as well as superior ride comfort.

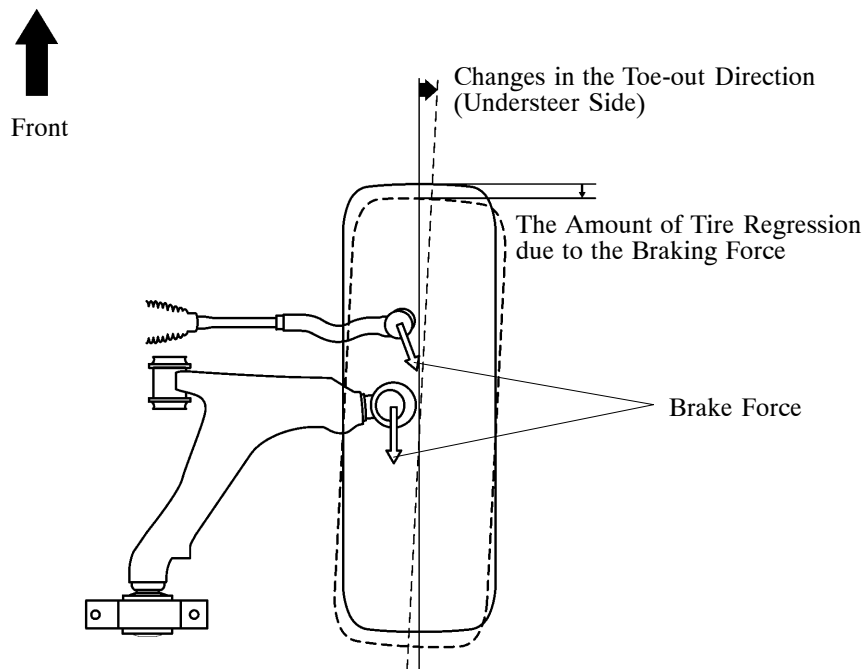

0140CH57Z

Optimized King Pin Offset

By adopting high-mount type front suspension upper arms, the offset between the tire center and the king pin is reduced at the axle center height. This reduces the moment (forces) around the king pin axis and suppresses the generation of flutter.

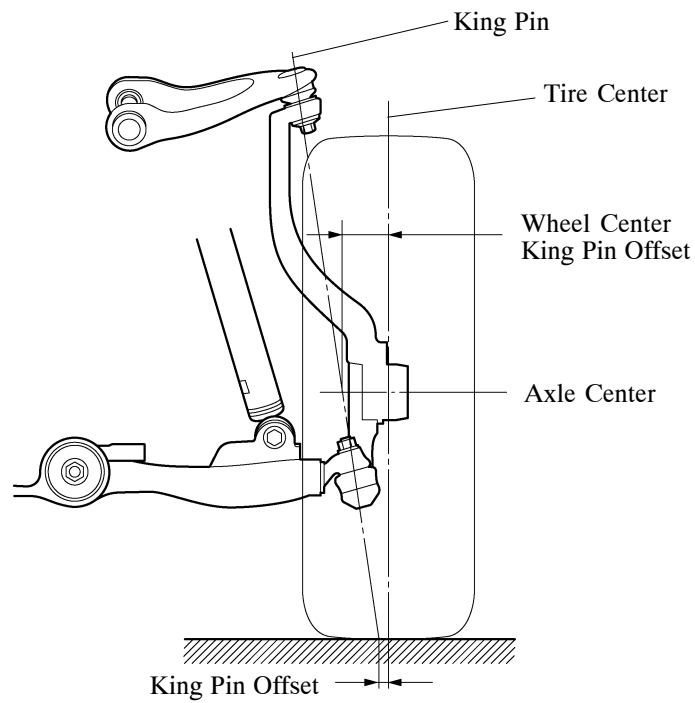

281CH18

Optimized Camber

Both the initial camber and the camber change rate have been optimized to ensure excellent driving stability.

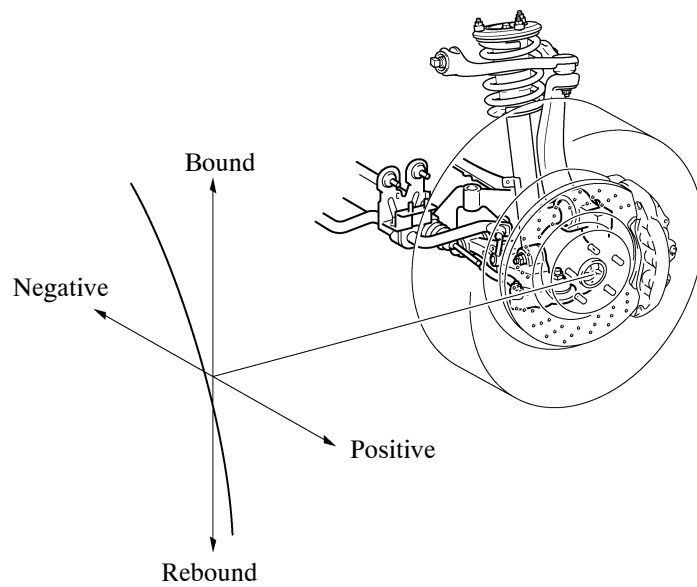

08D0CH82C

Anti-dive Geometry

- The front suspension lower arm is mounted to the body higher at the back than at the front, and the rear of the front suspension upper arm is set lower. As a result, the intersecting point “OF”, to which the lines extend geometrically from the lower and upper arms, has been set higher than the road surface.
- The intersecting point OF is in a position in which the vehicle body sustains the braking force BF that acts on the front wheels during braking. For this reason, the braking force BF generates the following components: the force BF1 that acts on the intersecting point OF, and the force BF2 that acts in the direction of the ground surface. The direction and the intensity of the force BF2 that acts in the direction of the ground surface vary by the position of the intersecting point OF. Thus, by setting the intersecting point OF at a position higher than the road surface, the increase in the front wheel load that is increased by the inertia during braking can be suppressed geometrically.

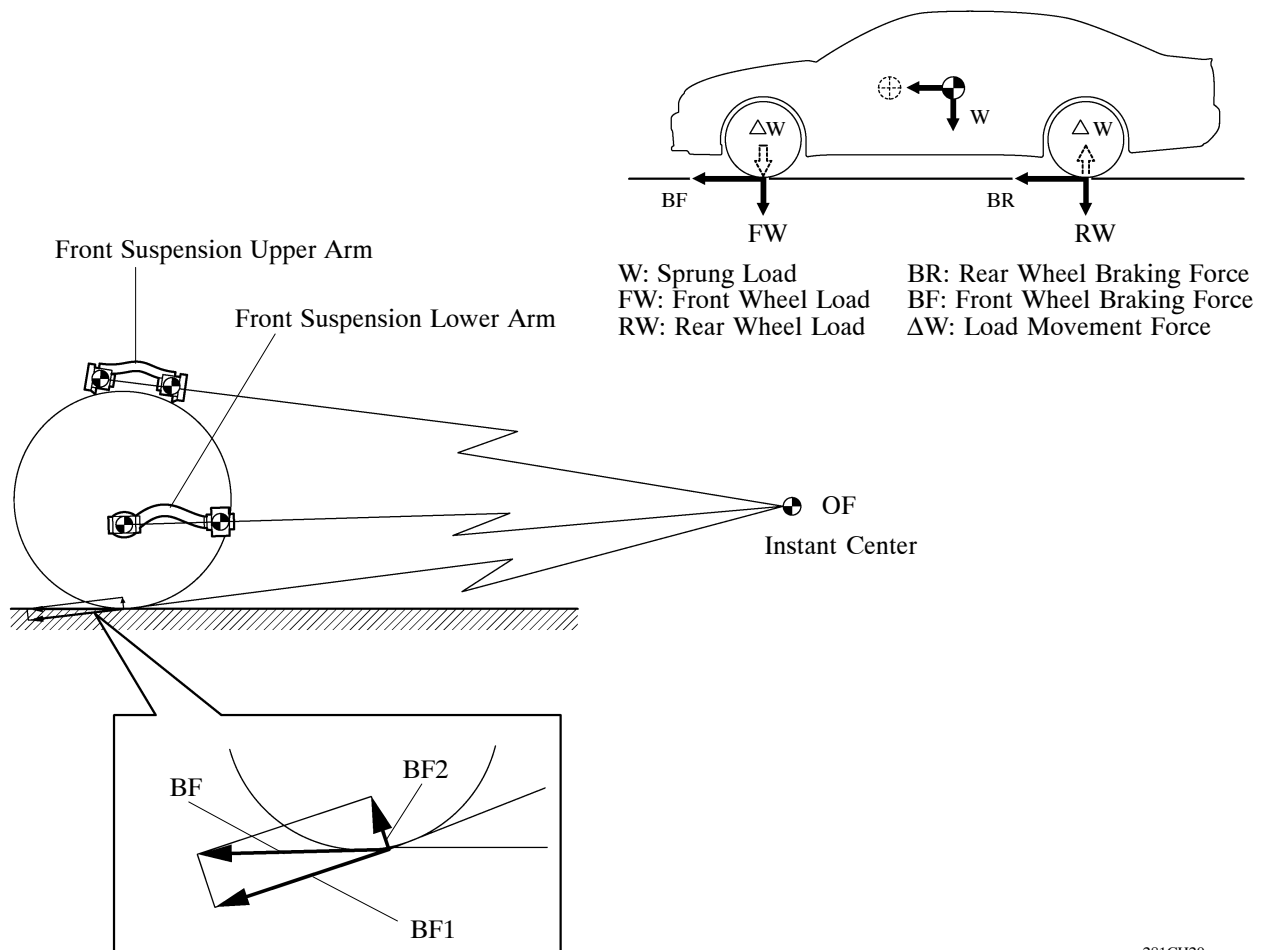

Front Suspension Upper Arm Assembly

The front suspension upper arm is made of high-strength sheet steel for weight reduction. The area that fits into the bushing has been burred, without a weld, to simplify the construction and reduce the weight.

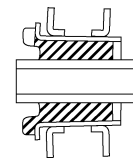
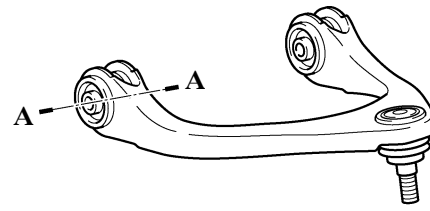

A - A Cross Section

08D0CH83C

Front Suspension Lower Arm Assembly

- The front suspension lower arms are made of high tensile sheet steel for weight reduction.
- A two-way split construction is used in the bushing in lower arm No.1. A preload pressure is applied axially to the rubber flange to increase its rigidity in the longitudinal direction.
- A large diameter liquid filled type bushing is used for the lower arm No.2 bushing for optimal vibration and harshness control.

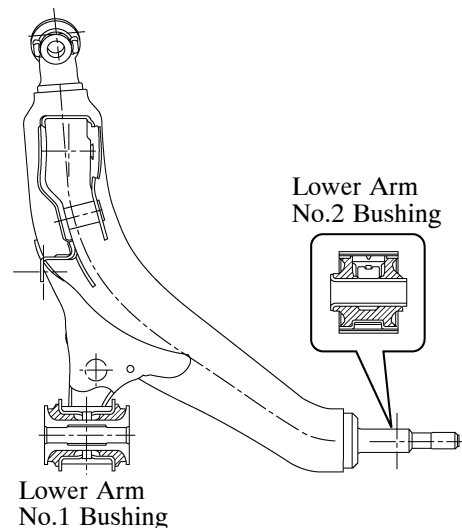

Lower Arm
No.1 Bushing

281CH21

Front Suspension Support Assembly

- The front suspension support assembly has adopted a load input dispersion construction. This provides support while dispersing the input loads from the front shock absorber, front coil spring and front spring bumper thus improving ride comfort and reducing noise and vibration.
- The front spring bumper comes into play early on in the compression stroke, working alongside the action of the spring to reduce roll angle when cornering and reduce nose-dive when braking.

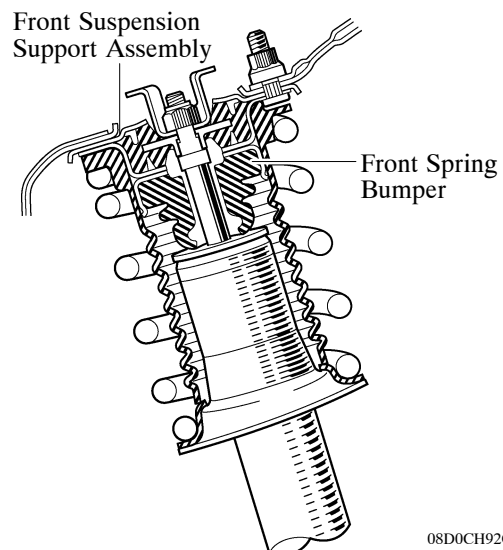

08D0CH92C

Front Shock Absorber Assembly

- A mono-tube type front shock absorber with a rebound spring and a multi-leaf type linear control valve is used.
- This front shock absorber generates a damping force starting with an extremely low piston speed range. Thus, it realizes a natural and linear vehicle behavior in response to driving maneuvers and a flat ride comfort. Furthermore, the proper response and continuity of the front shock absorber damping force have been ensured. This minimizes useless unsprung movement to ensure the proper road tracking capability and ride comfort.

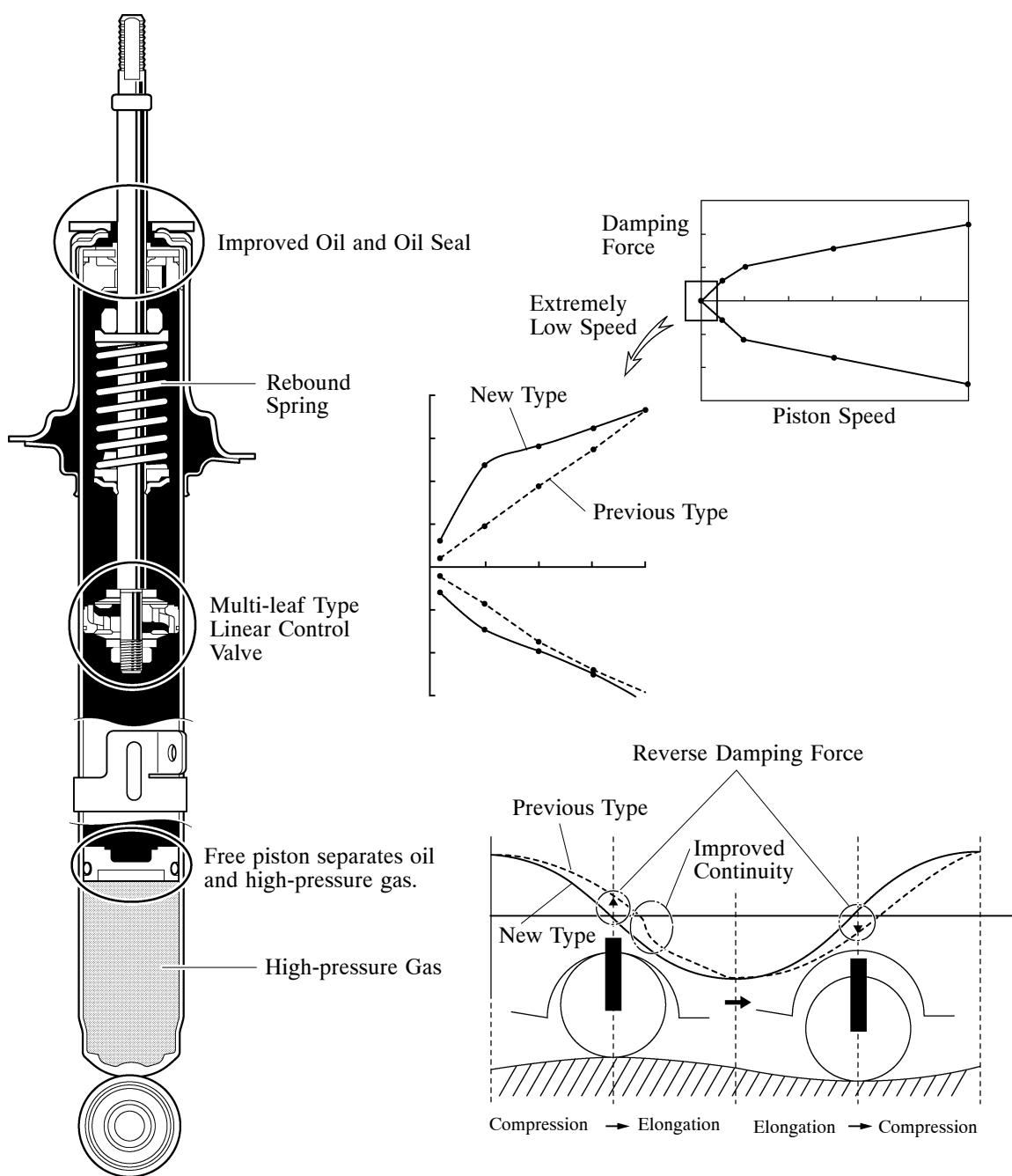

Front Stabilizer Bar

The front stabilizer bar is made of a hollow bar, reducing the weight. A ball joint is used between the front stabilizer link and the front stabilizer bar, and between the front stabilizer link and the front suspension lower arm. This helps reduce suspension friction and increase link rigidity.

As a result, the ball joints perform effectively even for slight roll forces, maintain stable roll feeling.

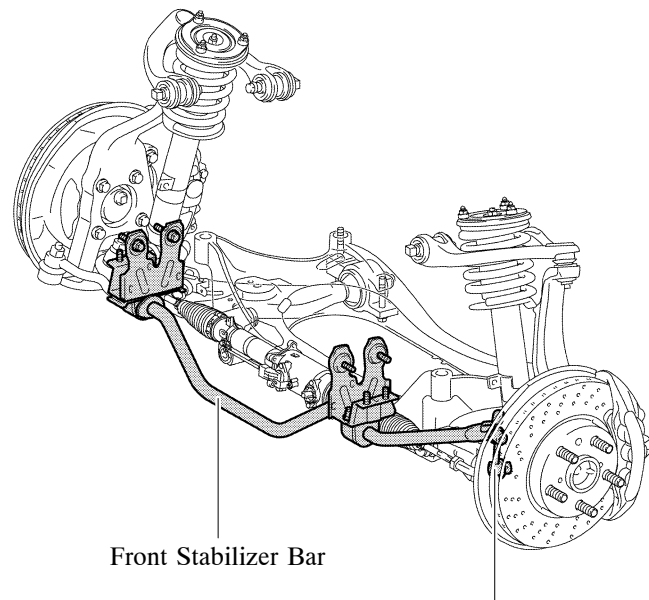

Front Stabilizer Bar

Front Stabilizer Link Assembly

08D0CH85Z

3. Rear Suspension

General

- A multi-link type rear suspension that consists of two upper control arms, two lower suspension arms and a toe control link.
- High-rate rear coil springs are used to reduce roll when cornering and reduce nose-dive when braking.
- The pressure of the gas inside the rear shock absorbers has been increased, ensuring good linear response during the initial damping stage.
- Cast-aluminum rear axle carriers are used for weight reduction.
- The length of rear upper No.1 and No.2 control arms has been changed, optimizing alignment and enhancing tire grip when driving.
- The characteristics of the toe control link bushings have been tuned to offer optimum toe variation when cornering.
- The rear suspension member cushions have been stiffened, reducing sway and ensuring stability when braking and accelerating. In addition, the position at which the suspension member is installed has been raised to optimize roll posture.

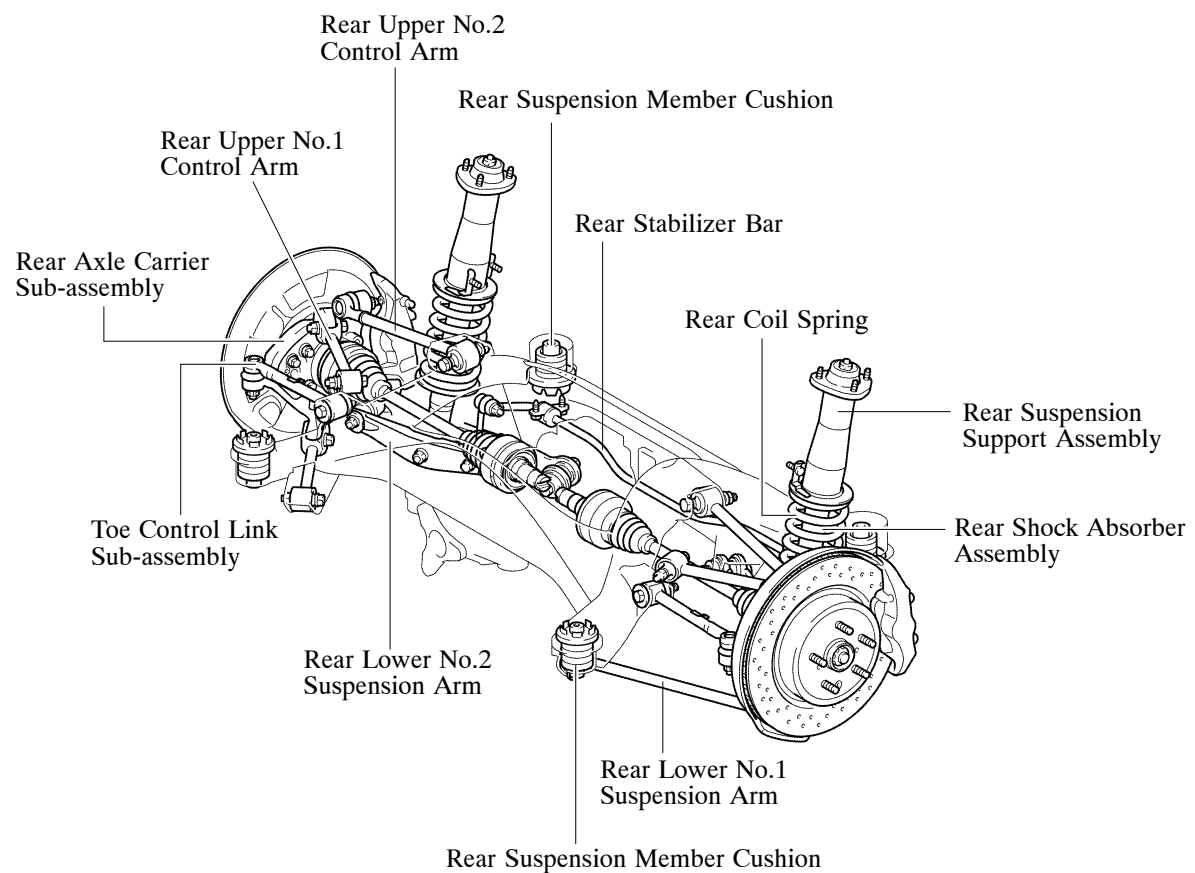

Optimized Roll Center

During a roll, a difference in the change in the height of the center of gravity is created geometrically depending on the setting of the roll center height and its rate of change. For this reason, the arms have been placed appropriately to achieve an optimal setting. As a result, the change in the height of the center of gravity is minimized and an excellent roll posture is ensured.

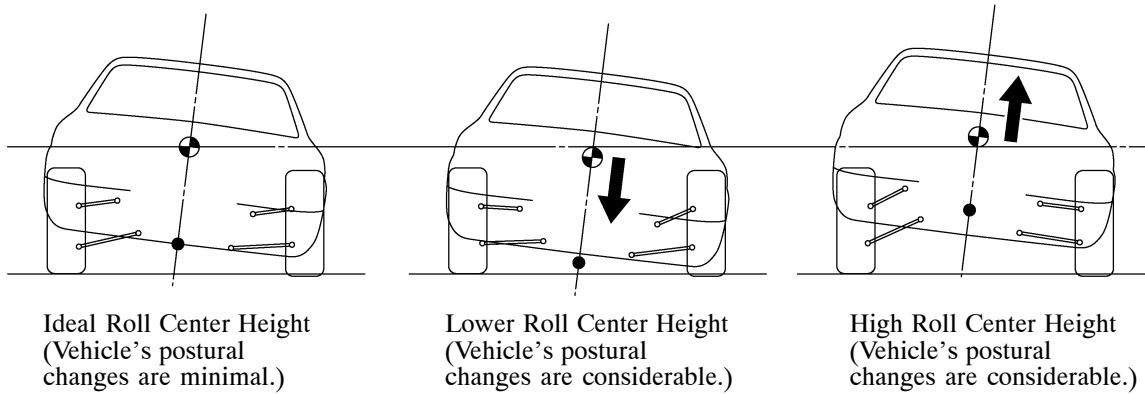

⊕ : Vehicle's Center of Gravity

● : Roll Center

199CH105

Optimized Camber

Both the initial camber and the camber change rate have been optimized to ensure excellent driving stability.

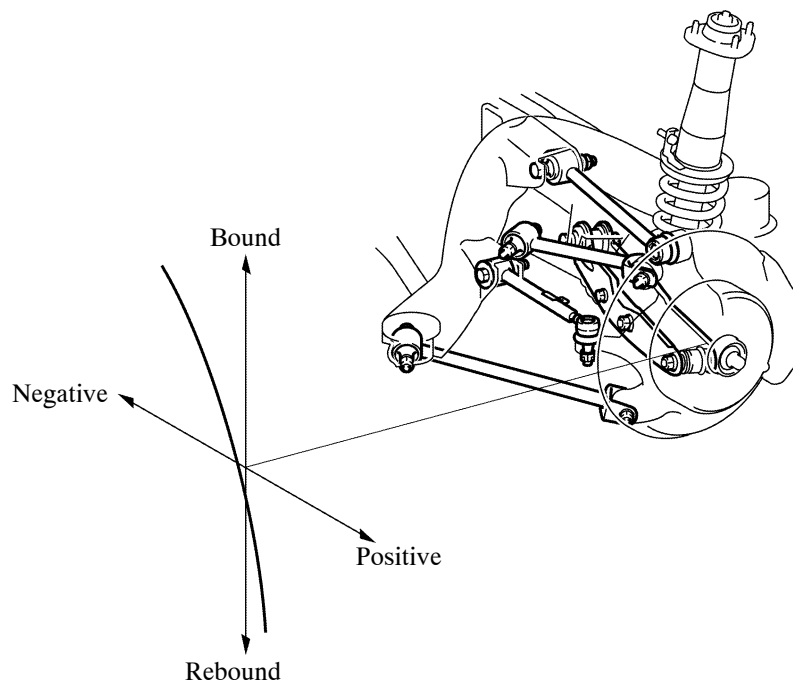

08D0CH91Z

Anti-lift

- During braking, the inertial force causes the center of gravity of the vehicle body to move, and reduces the load on the rear wheels. As a result, the back of the rear end of the vehicle lifts up.
- The vehicle body attempts to use the geometric intersecting point OR of the suspension to sustain the braking force that is generated at the road surface. Then, the braking force BF generates the following components: the force BF1 that acts on the intersecting point OR, and the force BF2 that acts in the direction of the ground surface. The direction and the intensity of this force, which acts in the direction of the ground surface, can be changed by changing the height of the intersecting point OR. Thus, by setting it at a position higher than the road surface, it acts in the opposite direction of the load movement ΔW , and suppresses the lifting of the rear end of the vehicle.

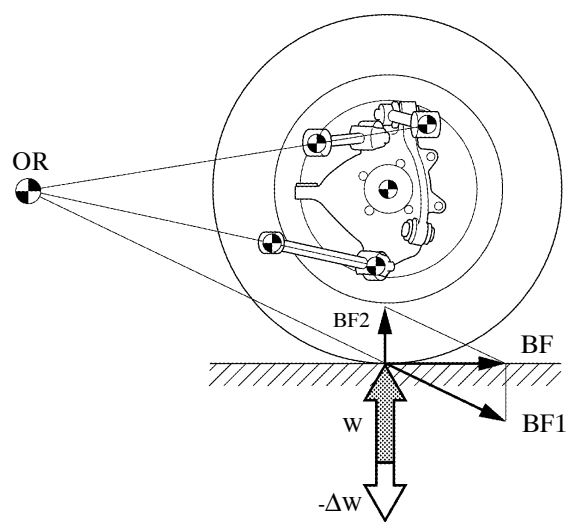

0140CH64Z

Anti-squat

- During start off or acceleration, the inertial force causes the center of gravity of the vehicle body to move. This increases the load on the rear wheels, causing the rear end of the vehicle to squat.
- The vehicle body uses the geometric intersecting point OR of the suspension to sustain the drive force that acts on the axle center. Then, the drive force T generates the following components: the force T1 that acts in the direction of the intersecting point, and the force T2 that acts in the direction of the ground surface. By setting the intersecting point OR at a position higher than the axle center, the force that acts in the direction of the ground surface will cancel out the load ΔW that increases with the start off or acceleration. As a result, it suppresses the squatting of the rear end of the vehicle.

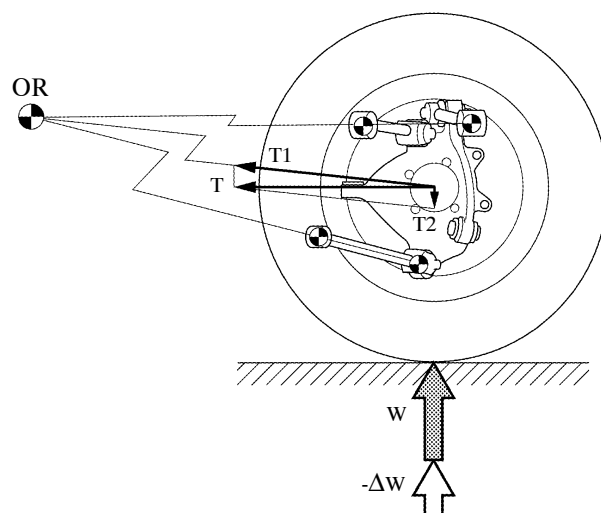

0140CH65Z

Optimizing Longitudinal Compliance

When the vehicle goes over a bump on the road, a load is input to the axle center in the rear direction of the vehicle. The longitudinal movement of the axle in response to the load that is input from the road surface at this time is called “longitudinal compliance”. The ride comfort can be improved by setting a large compliance. For this reason, the spring constant of the bushing in rear upper No.1 control arm, which bears a small input load during braking, is reduced to ensure ample longitudinal compliance. Furthermore, the spring constant of the rear lower suspension arm bushing is increased to suppress the changes in the toe angle during a braking load. As a result, both excellent ride comfort and high levels of driving stability are realized.

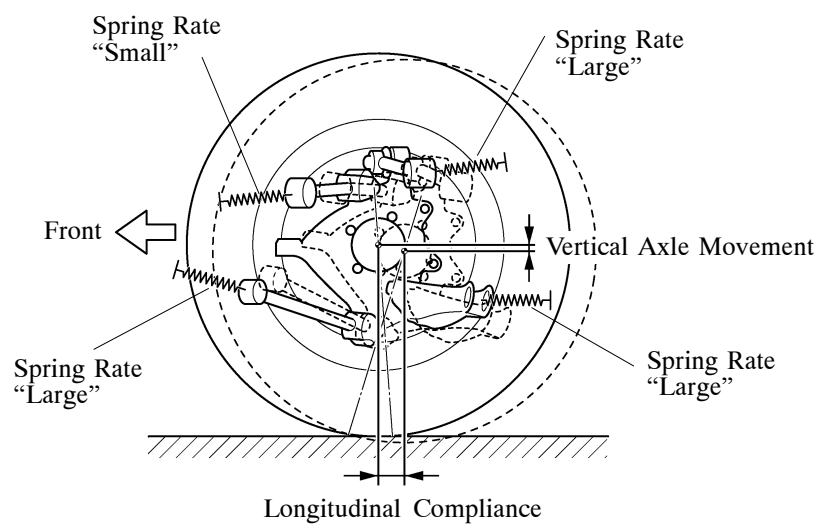

Rear Upper Control Arm, Rear Lower Suspension Arm and Toe Control Link Sub-assembly

- A rear upper No.1 control arm and rear lower No.1 suspension arm made of high-strength pipe material are used to ensure high rigidity and weight reduction.
- A rear upper No.2 control arm and toe control link made of high-strength pipe material and a ball joint at one end are used to ensure high rigidity and weight reduction.
- A rear lower No.2 suspension arm made of stamped high-strength sheet steel is used to ensure high rigidity. On the rear suspension member side, a bushing with an external cylinder is used, and on the rear axle side, a pillow ball bushing is used to realize high support rigidity and excellent ride comfort.

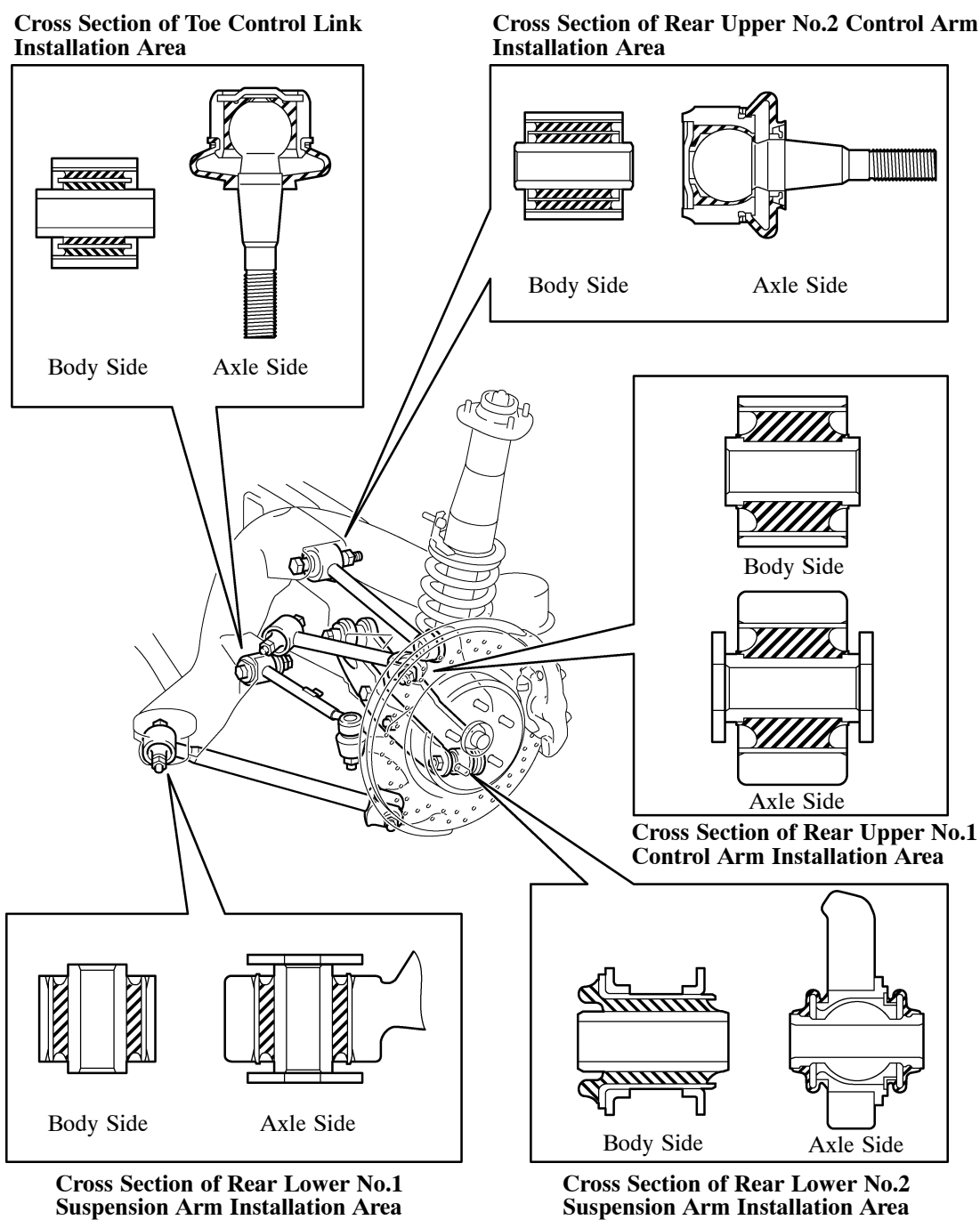

Rear Suspension Support Assembly, Rear Coil Spring and Rear Shock Absorber Assembly

- A rear suspension support assembly with separate inputs is used to realize both excellent ride comfort and driving stability.
- A horizontal force is created by the deviation of the center axis at the landing point or the angle of the spring seat during the contraction or elongation of the rear coil spring. This force is separate from the vertical force, which is the primary movement of the spring. Thus, by positioning the spring seat in the lower area of the rear shock absorber, the rear shock absorber can slide smoothly to ensure excellent ride comfort.
- Along with the low position of the rear coil springs, a cylindrical, rear suspension support assembly (upper spring seat) is used.
- The shape of the rear spring bumper made of urethane is optimized to realize both excellent ride comfort and driving stability. Furthermore, the rear spring bumper comes into play early on in the compression stroke, working alongside the action of the spring to reduce roll angle when cornering.
- A mono-tube type rear shock absorber is used to optimize the damping characteristics.
- A rear upper coil spring insulator is provided in the upper spring area to ensure stability to counter disturbance.
- A rear lower coil spring insulator is provided at the bottom of the spring to reduce noise and vibration.

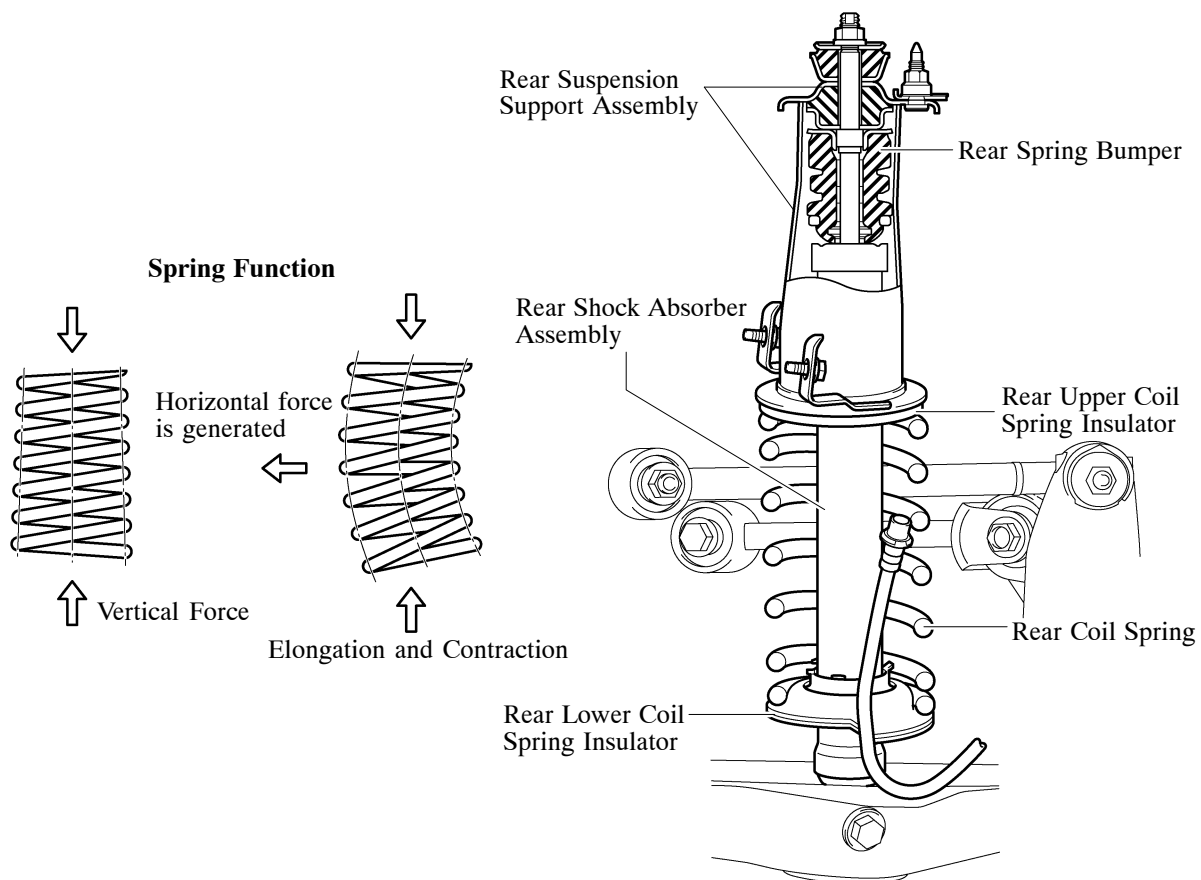

Rear Stabilizer Bar

- A highly rigid, solid type rear stabilizer bar is used.
- A ball-joint type rear stabilizer link assembly is used to ensure excellent response and rigidity.

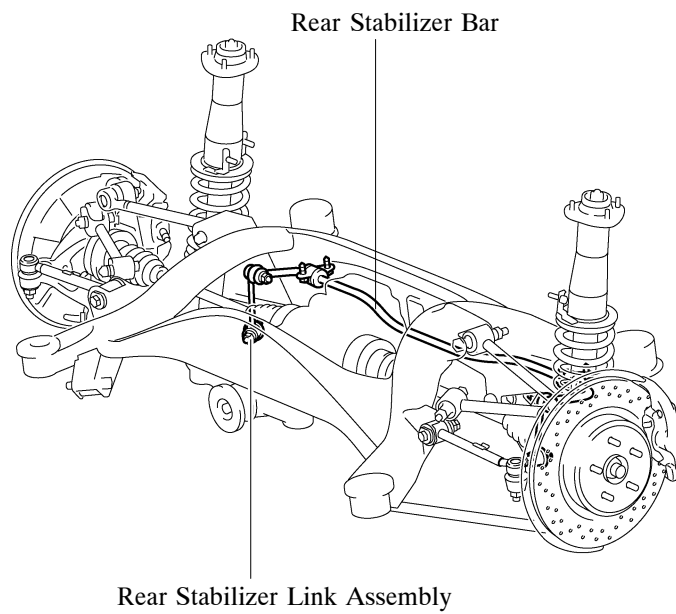

08D0CH89C

■ AXLE

1. Front Axle

- A compact and highly rigid double-row angular ball bearing is used on the front axle. The double-row angular ball bearing and the axle hub have been integrated to ensure high rigidity, thus realizing excellent driving stability and braking stability. In addition, the bearing races have been optimized in consideration of high Gs experienced when turning while driving in a sporty manner, ensuring reliability.
- An active type speed sensor, which is capable of detecting extremely low rotation speeds, is used. The active speed sensor and the magnet type rotor are a built-in type.

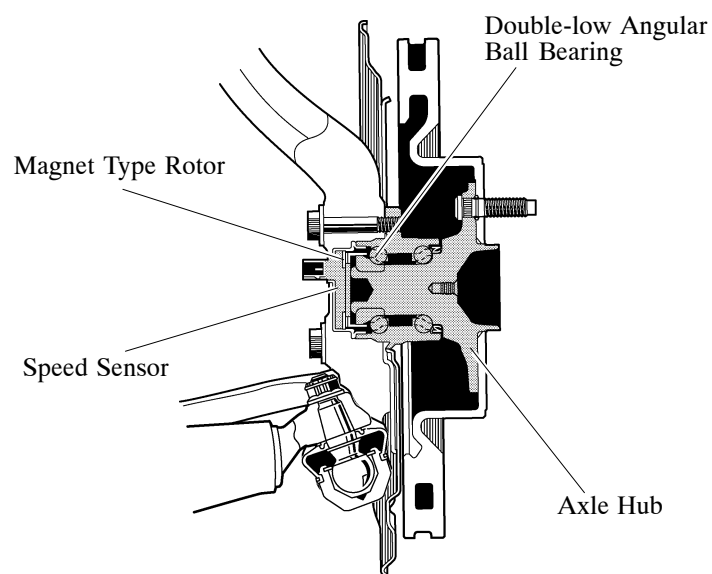

08D0CH90C

2. Rear Axle

- The rear axle uses compact and highly rigid double-row angular ball bearings. The bearings and the axle hub have been integrated to ensure high rigidity, thus realizing excellent driving and braking stability.
- A 12-point lock nut is used and staked in order to ensure that the axle hub is properly secured. Once removed, this nut cannot be reused.

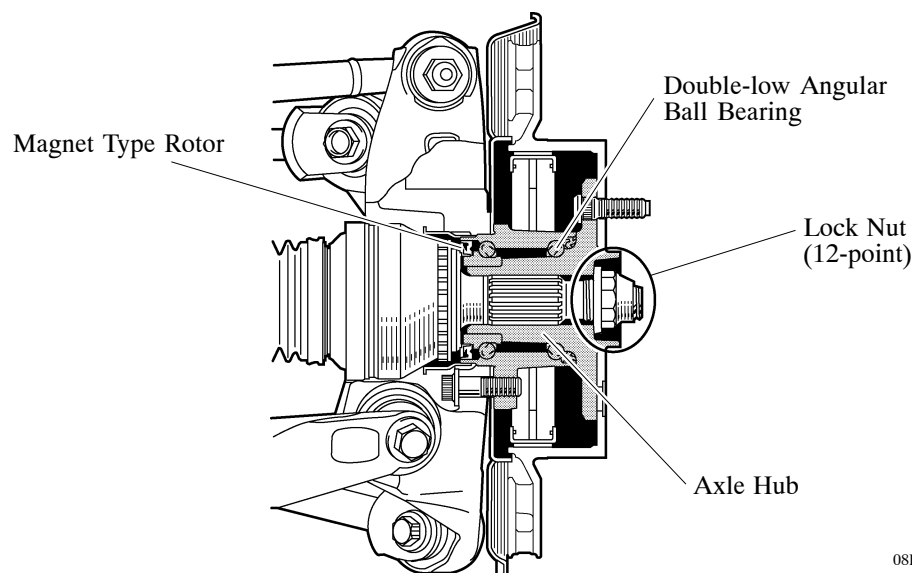

08D0CH116C