

Last Modified: 7-13-2007		1.6 A
Service Category: Vehicle Exterior	Section: Exterior Panels/Trim	
Model Year: 2008	Model: ES350	Doc ID: RM000000MNG00GX
Title: EXTERIOR: ROOF DRIP SIDE FINISH MOULDING: INSTALLATION (2008 ES350)		

INSTALLATION

1. INSTALL ROOF DRIP SIDE FINISH MOULDING CLIP

NOTICE:

If installing new clips, remove the double-sided tape remaining where the clips will be installed on the body and clean the body with a non-residue type solvent.

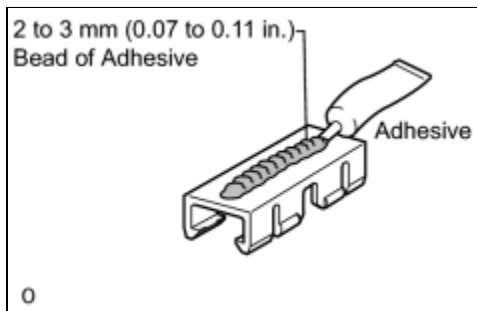

(a) Apply a 2 to 3 mm (0.07 to 0.11 in.) bead of adhesive (3M DP-105 or equivalent) to new roof drip side finish moulding clips.

HINT:

Adhesive strength (tensile strength): 13.7 MPa (140 kgf/cm²) or more (when the temperature is 23°C)

(b) Install the roof drip side finish moulding clips to the positions on the roof panel shown in the illustration. Determine the locations and firmly press and install the roof drip side finish moulding clips after lightly rubbing up adhesive (3M DP-105 or equivalent).

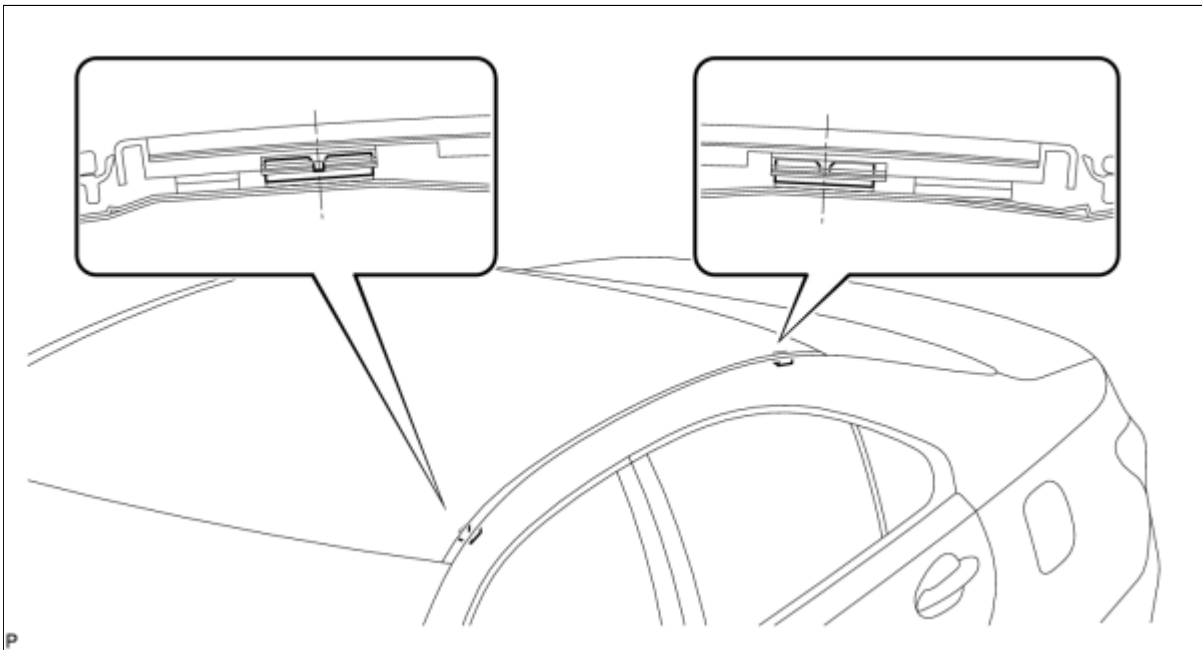

HINT:

- Initial hardening time: 20 minutes
- Complete hardening time: 48 hours

2. INSTALL ROOF DRIP SIDE FINISH MOULDING CENTER

HINT:

When installing the roof drip side finish moulding center, heat the vehicle body and roof drip side finish moulding center using a heat light.

Heating temperature:

ITEM	TEMPERATURE
Vehicle Body	40 to 60°C (104 to 140°F)
Moulding	20 to 30°C (68 to 86°F)

NOTICE:

Do not heat the vehicle body and roof drip side finish moulding center excessively.

- (a) Clean the vehicle body surface.
 - (1) Using a heat light, heat the vehicle body surface.
 - (2) Remove the double-sided tape from the vehicle body.
 - (3) Wipe off any tape adhesive residue with cleaner.
- (b) Clean the roof drip side finish moulding center. (If reusing the roof drip side finish moulding center)

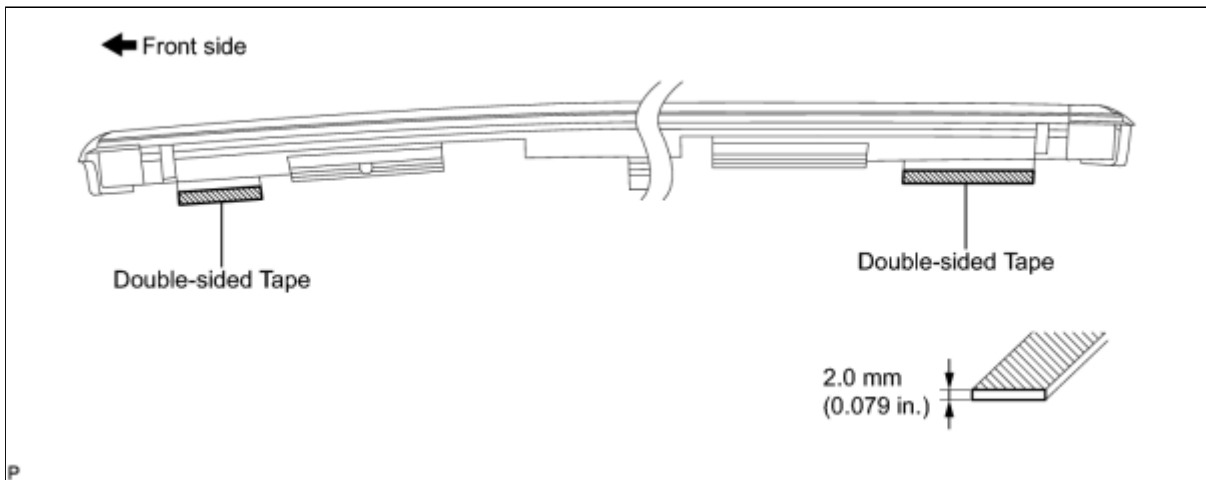

- (1) Using a heat light, heat the roof drip side finish moulding center.
 - (2) Remove the double-sided tape from the roof drip side finish moulding center.
 - (3) Wipe off any tape adhesive residue with cleaner.
 - (4) Apply new double-sided tape to the roof drip side finish moulding center.
- (c) Install the roof drip side finish moulding center.

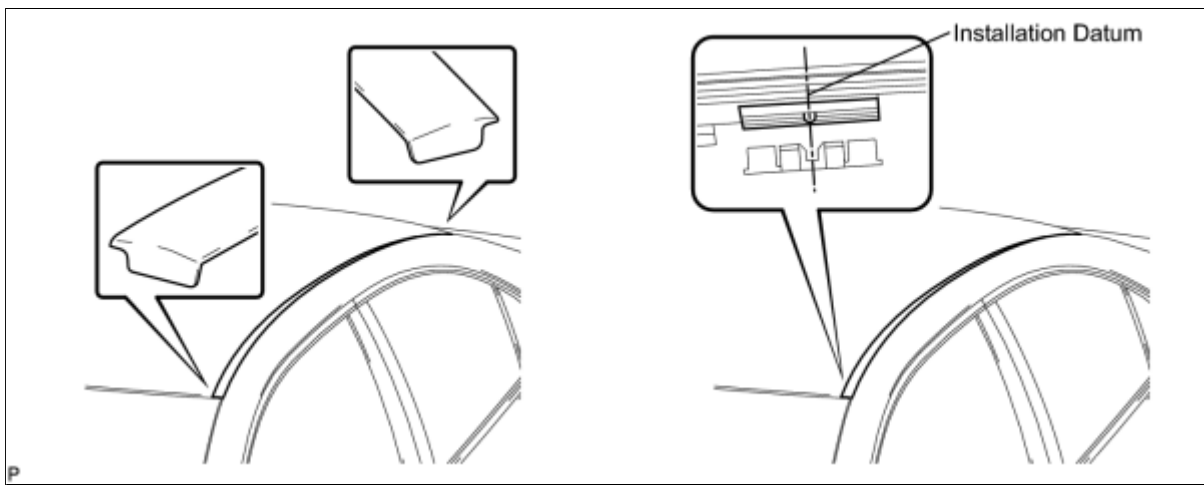

- (1) Using a heat light, heat the vehicle body and roof drip side finish moulding center.
- (2) Remove the release paper from the roof drip side finish moulding center.

HINT:

After removing the release paper, keep the exposed adhesive free from foreign matter.

- (3) Install the roof drip side finish moulding center when 20 minutes or more have elapsed after pressing and installing the roof drip side finish moulding clips.

NOTICE:

- Install the roof drip side finish moulding center in the proper direction.
- Set the front clip to the installation datum. Make sure that the front clip and roof drip side finish moulding center are fit each other.

