

Last Modified: 7-13-2007		1.7 K
Service Category: Vehicle Interior	Section: Heating/Air Conditioning	
Model Year: 2008	Model: ES350	Doc ID: RM0000027DV000X
Title: AIR CONDITIONING: BLOWER UNIT: COMPONENTS (2008 ES350)		

[COMPONENTS](#)

[ILLUSTRATION](#)

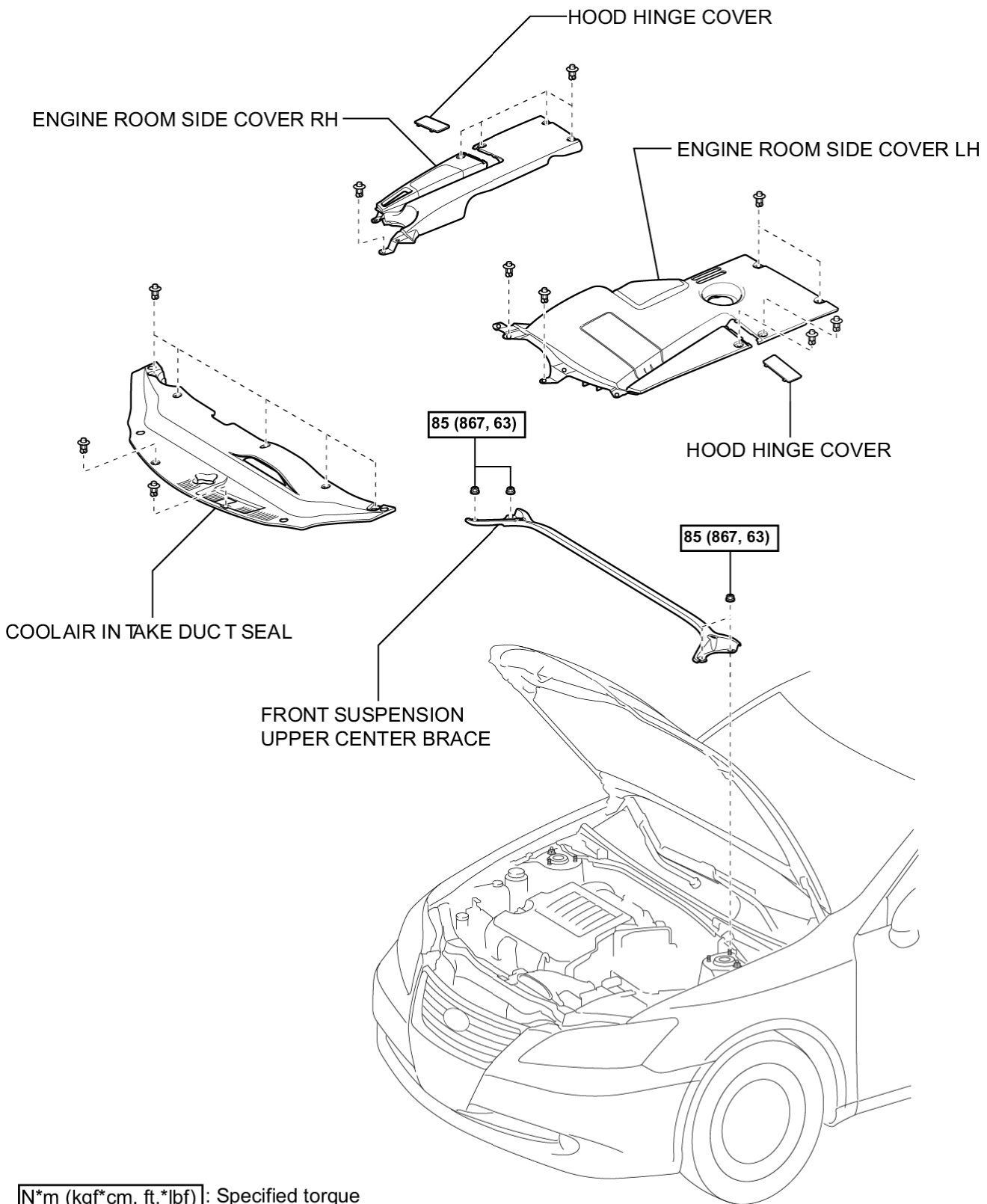

N*m (kgf*cm, ft.*lbf): Specified torque

c

ILLUSTRATION

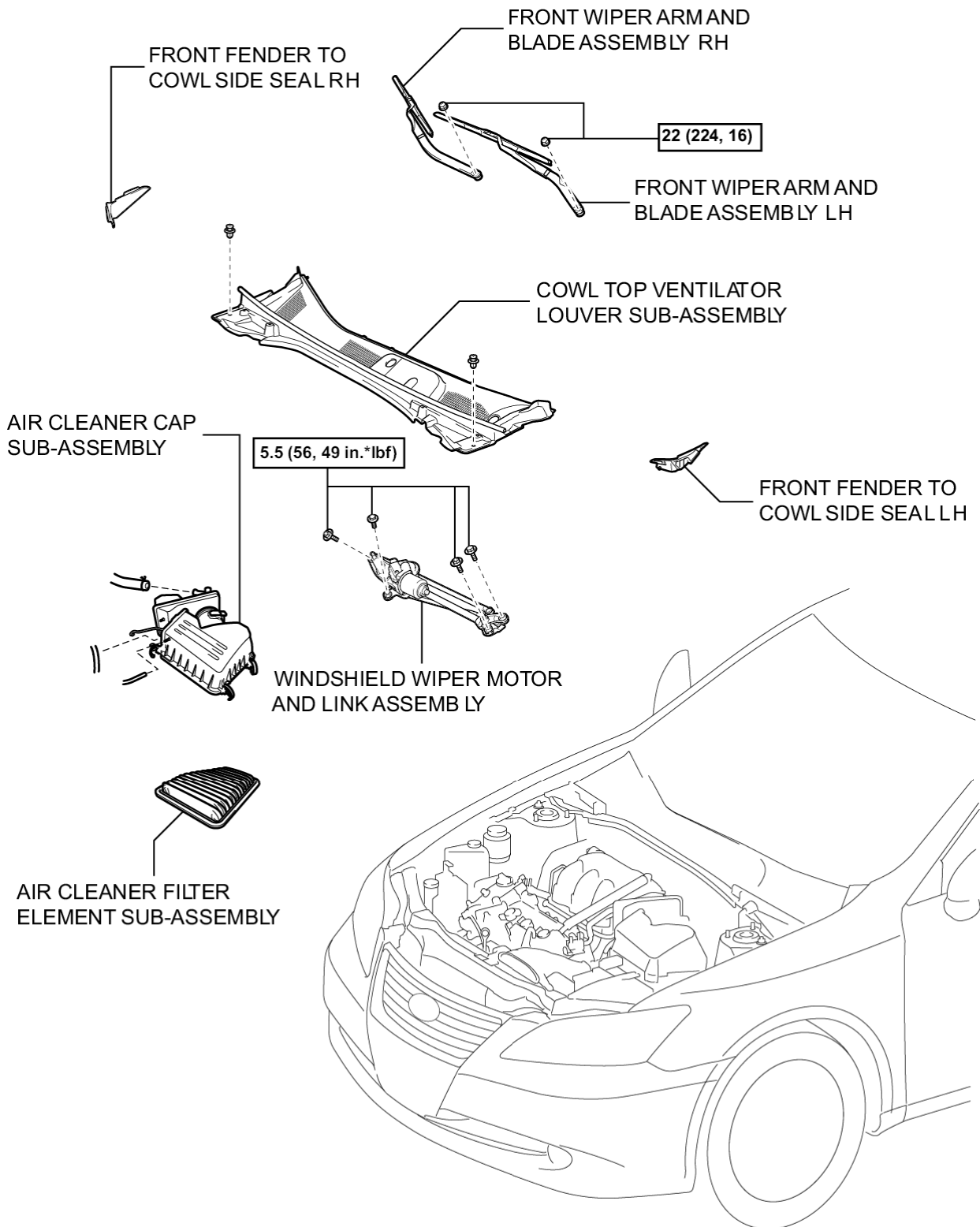

N*m (kgf*cm, ft.*lbf) : Specified torque

P

ILLUSTRATION

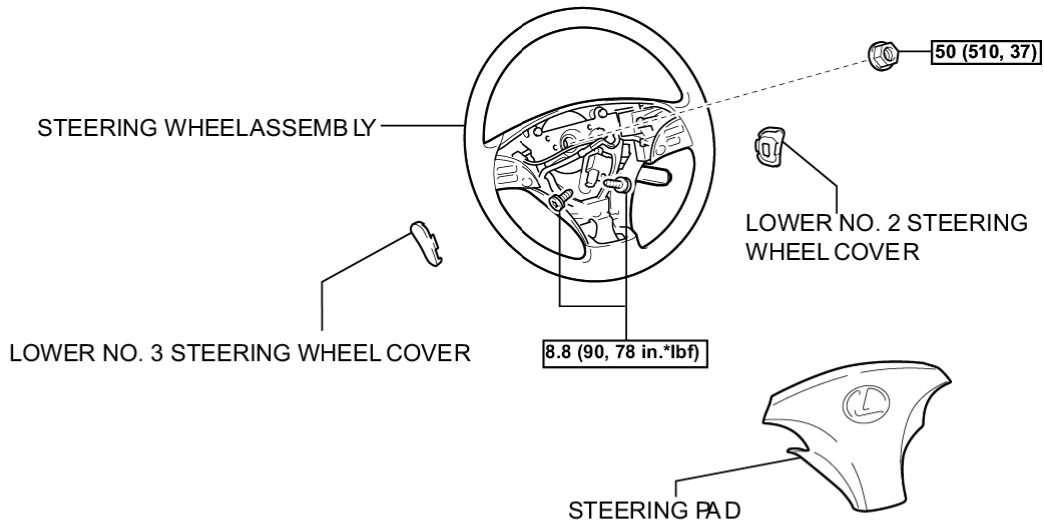
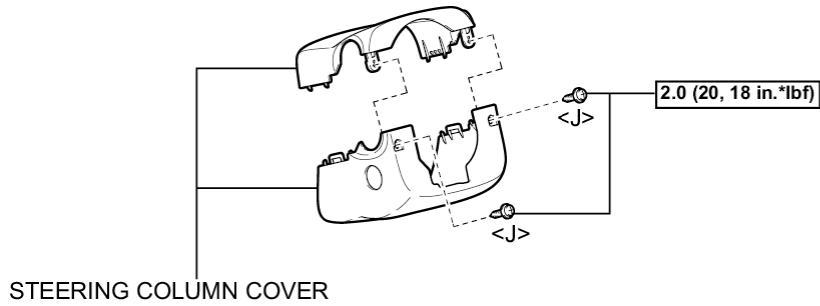
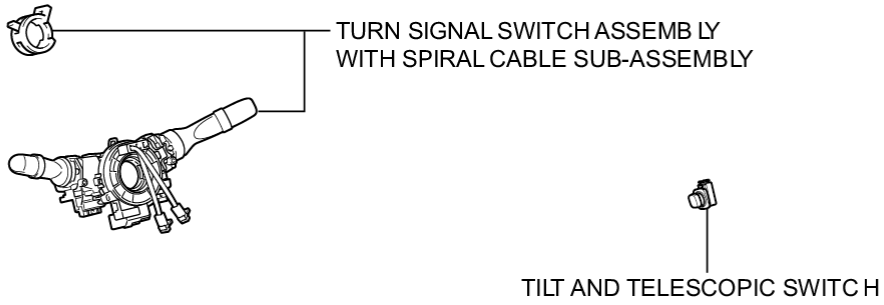

N*m (kgf*cm, ft.*lbf) : Specified torque

P

ILLUSTRATION

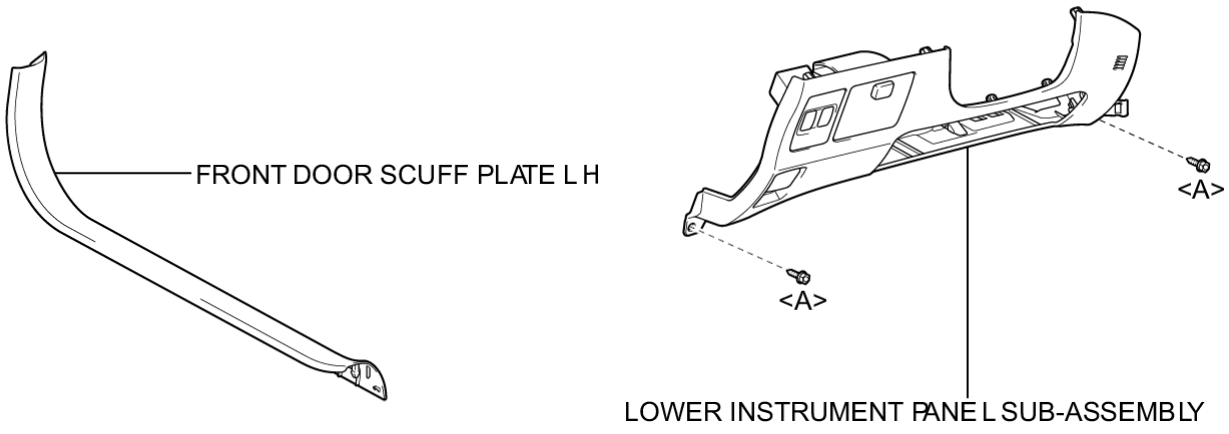
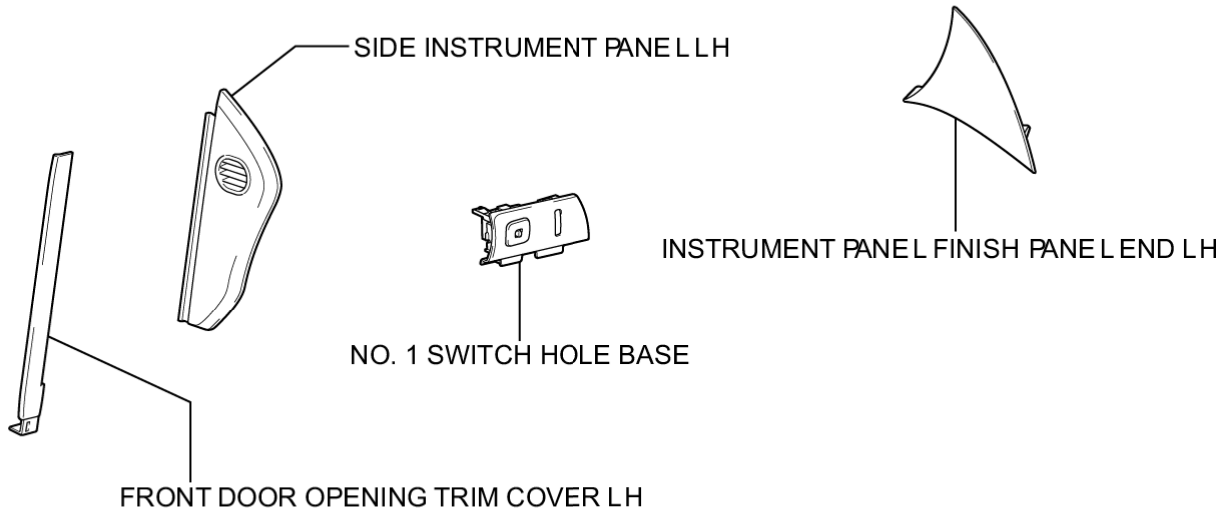
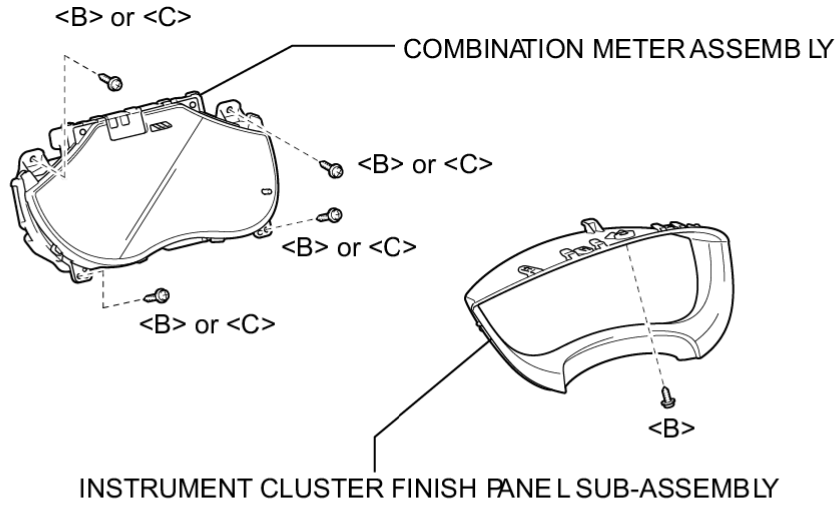

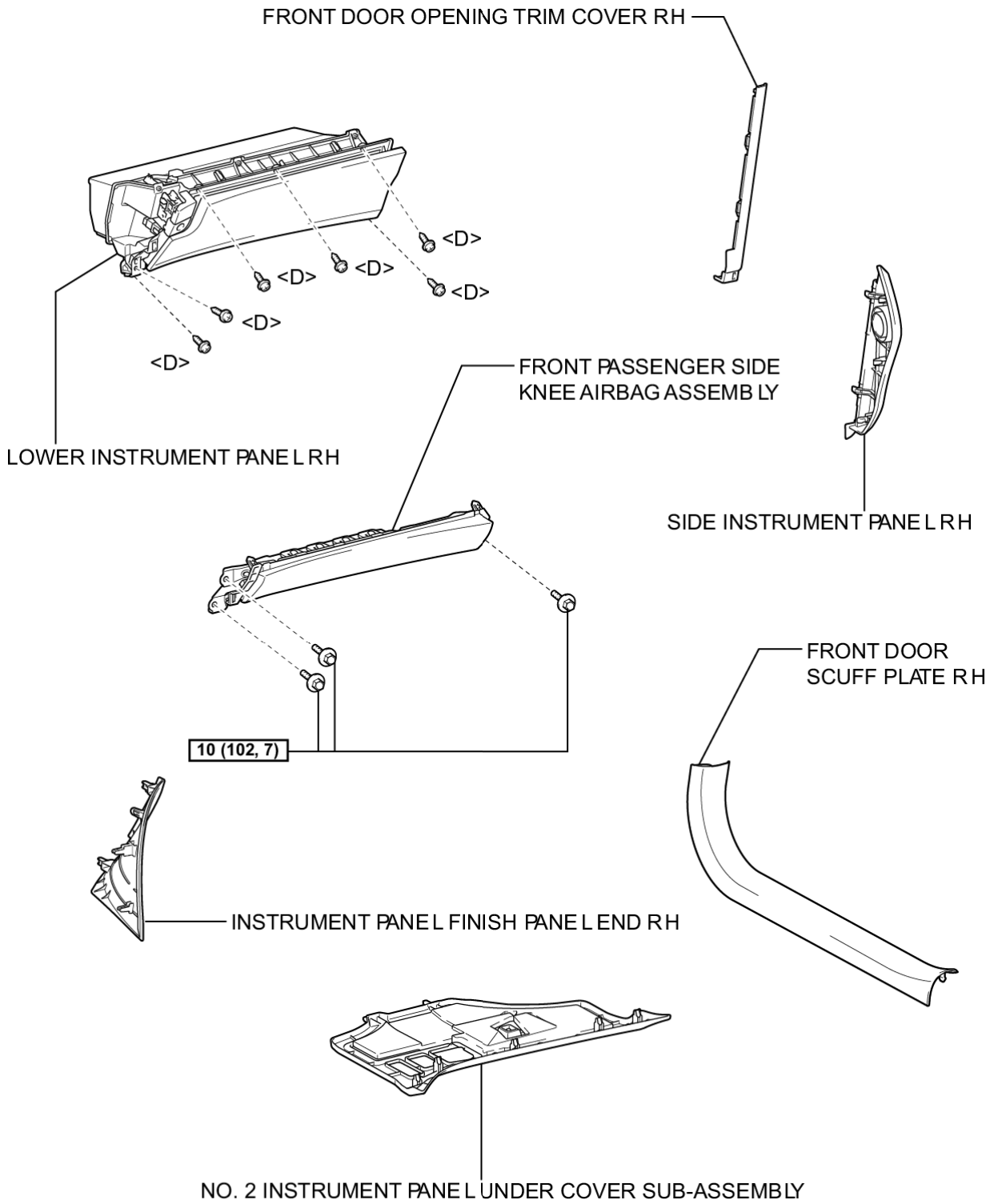

N*m (kgf*cm, ft.*lbf): Specified torque

ILLUSTRATION

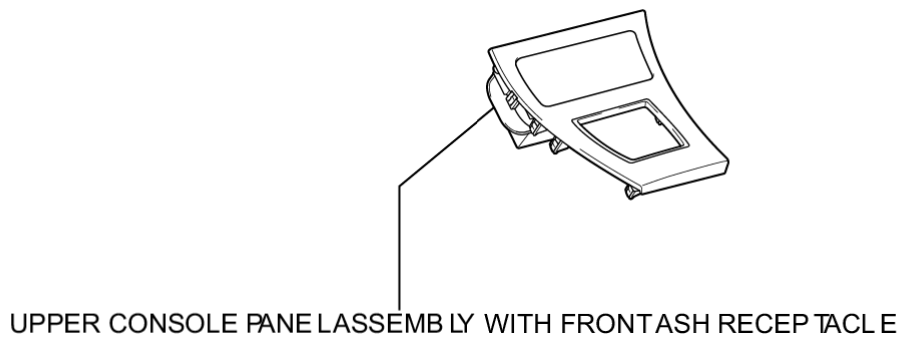
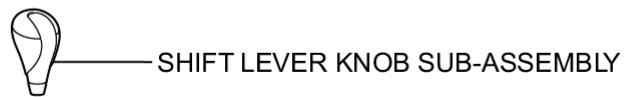
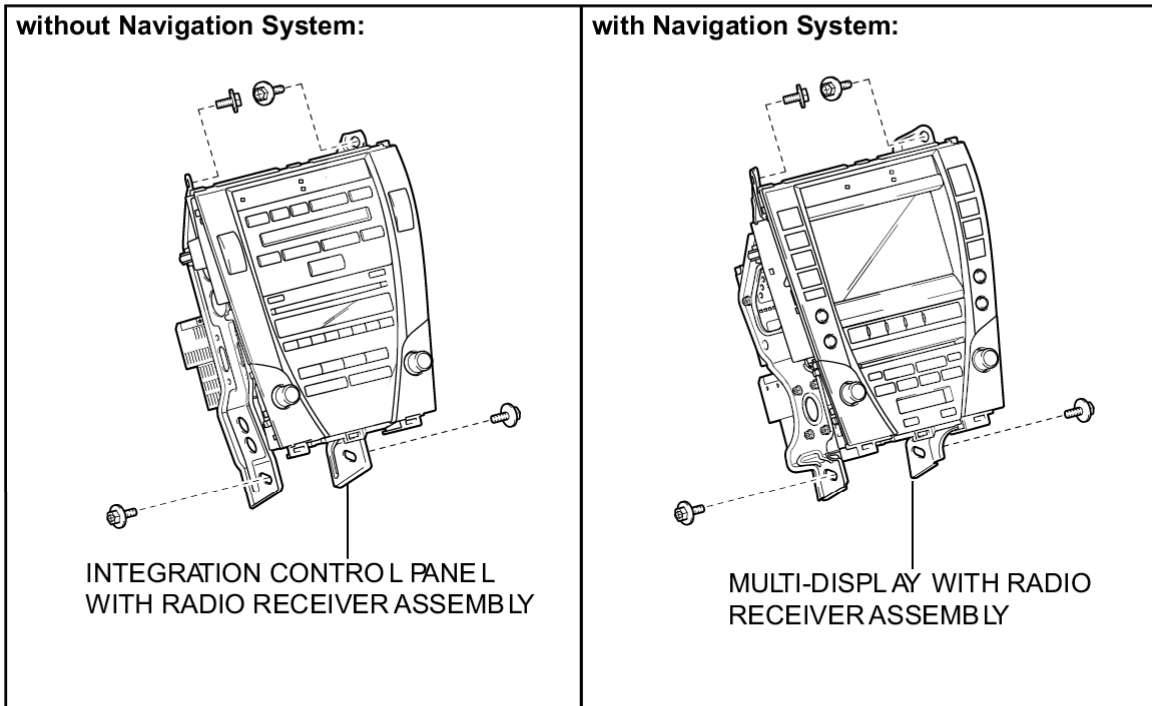
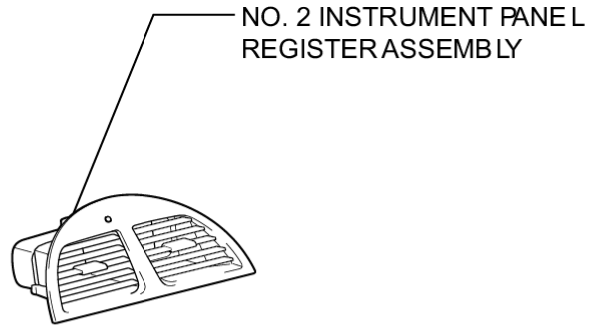

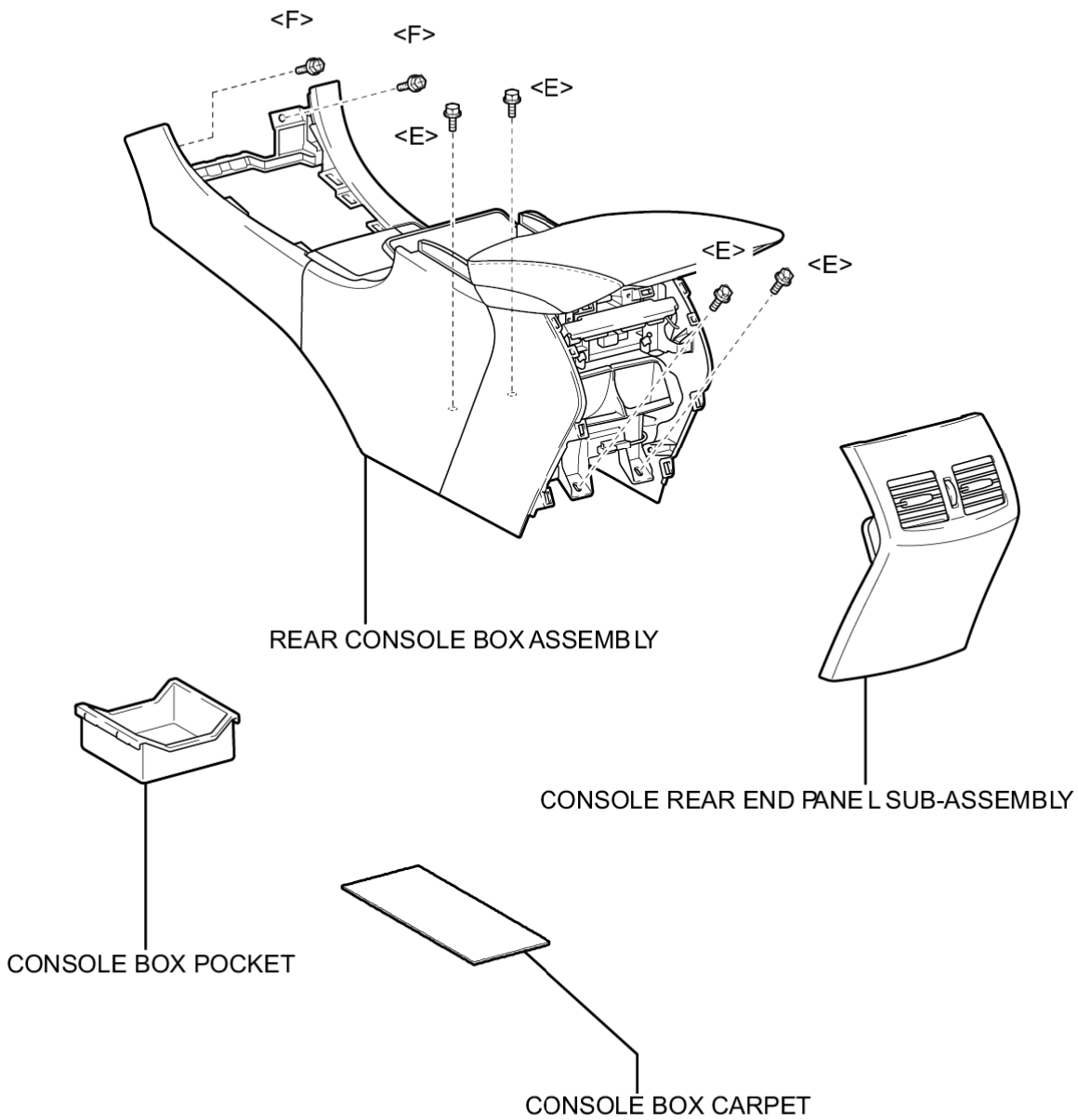
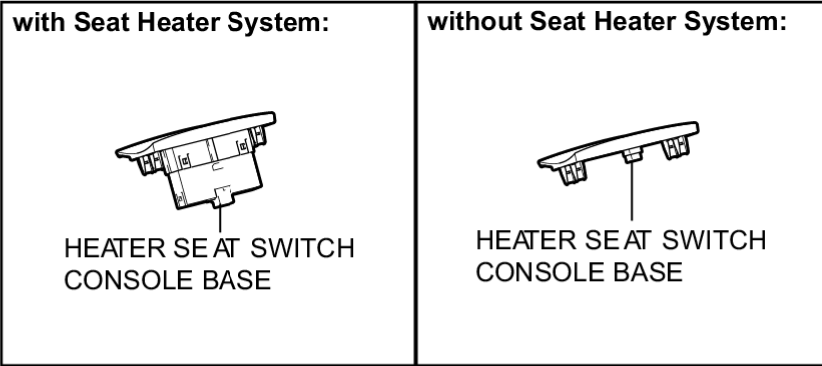

ILLUSTRATION

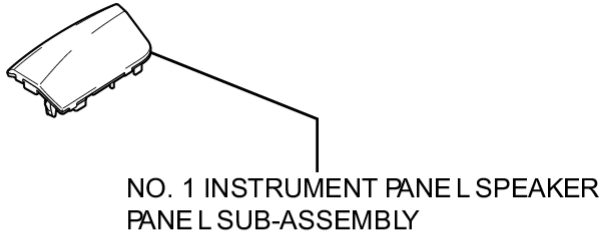

without Rear Header Speaker:

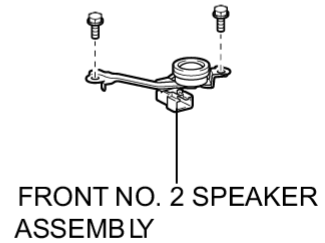
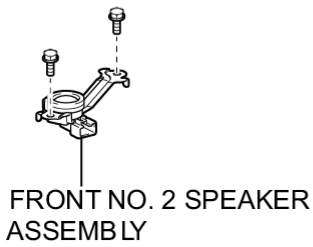

with Rear Header Speaker:

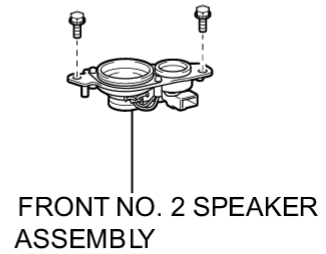
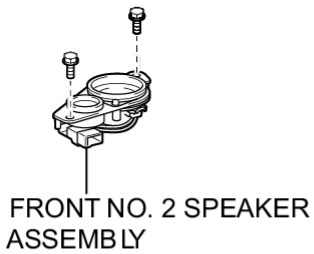

● FRONT PILLAR GARNISH CLIP

● FRONT PILLAR GARNISH CLIP

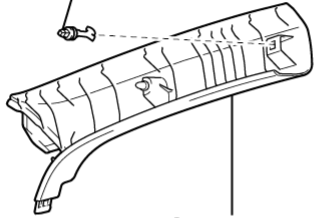

FRONT PILLAR GARNISH LH

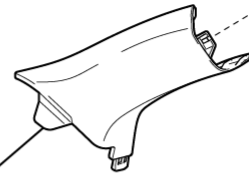

FRONT PILLAR GARNISH RH

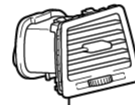

NO. 3 INSTRUMENT PANEL REGISTER ASSEMBLY



NO. 1 INSTRUMENT PANEL REGISTER ASSEMBLY

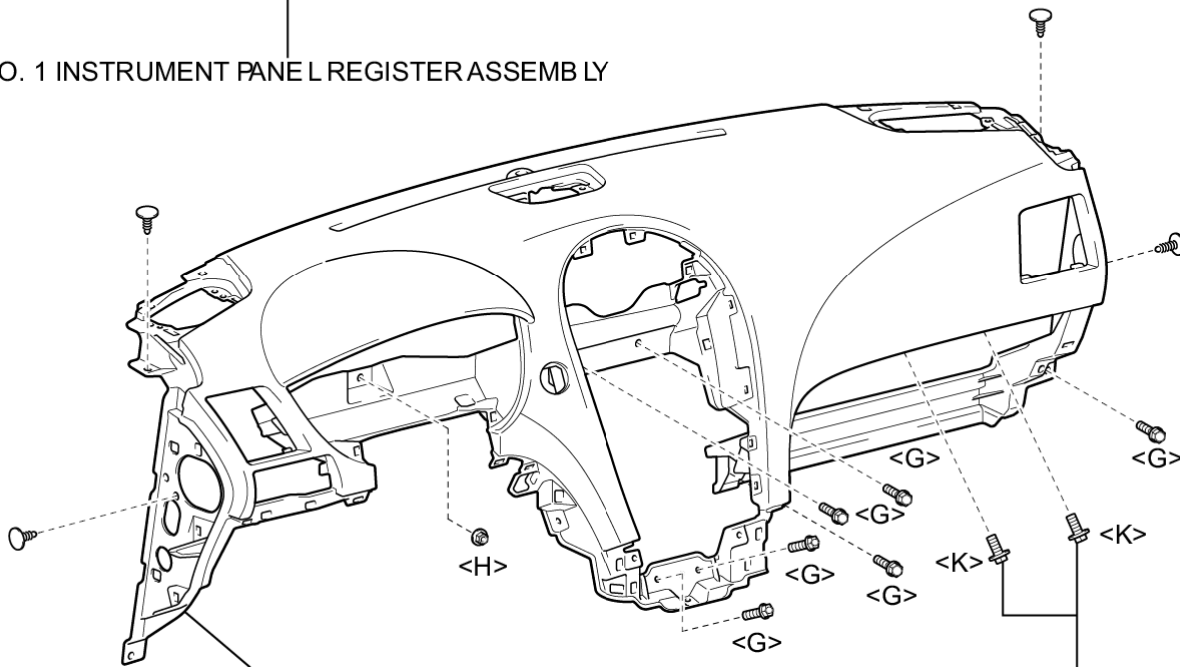

INSTRUMENT PANEL SAFETY PAD ASSEMBLY

PUSH START SWITCH

NO. 1 INSTRUMENT PANEL MOUNTING BRACKET

N*m (kgf*cm, ft.*lbf) : Specified torque

● Non-reusable part

ROOM TEMPERATURE SENSOR

ILLUSTRATION

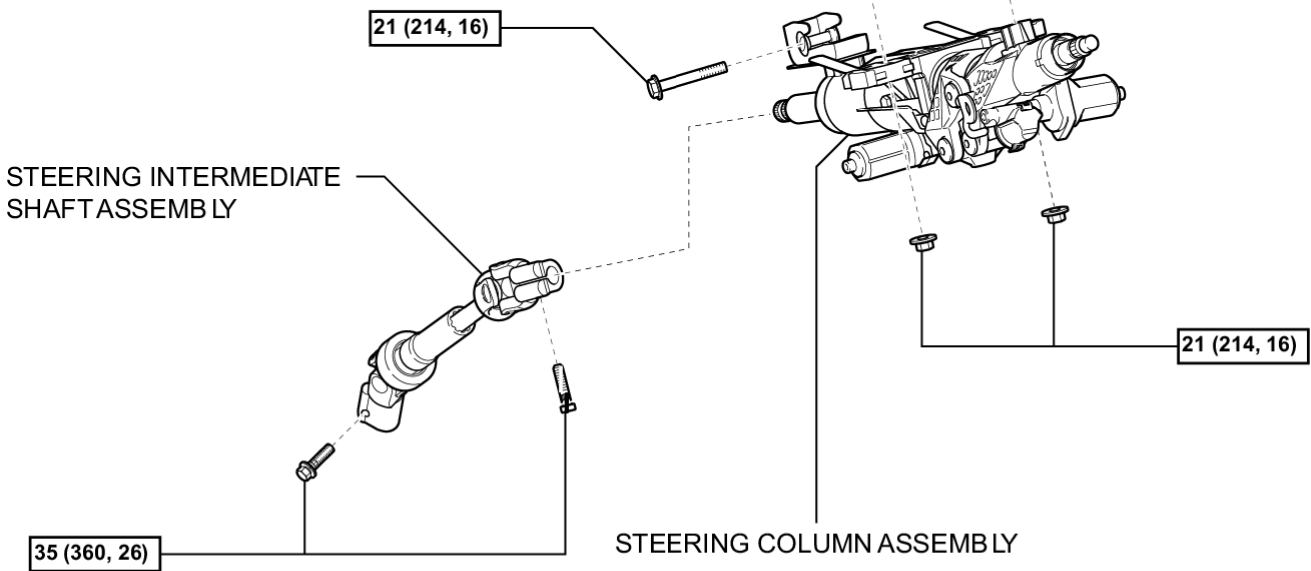
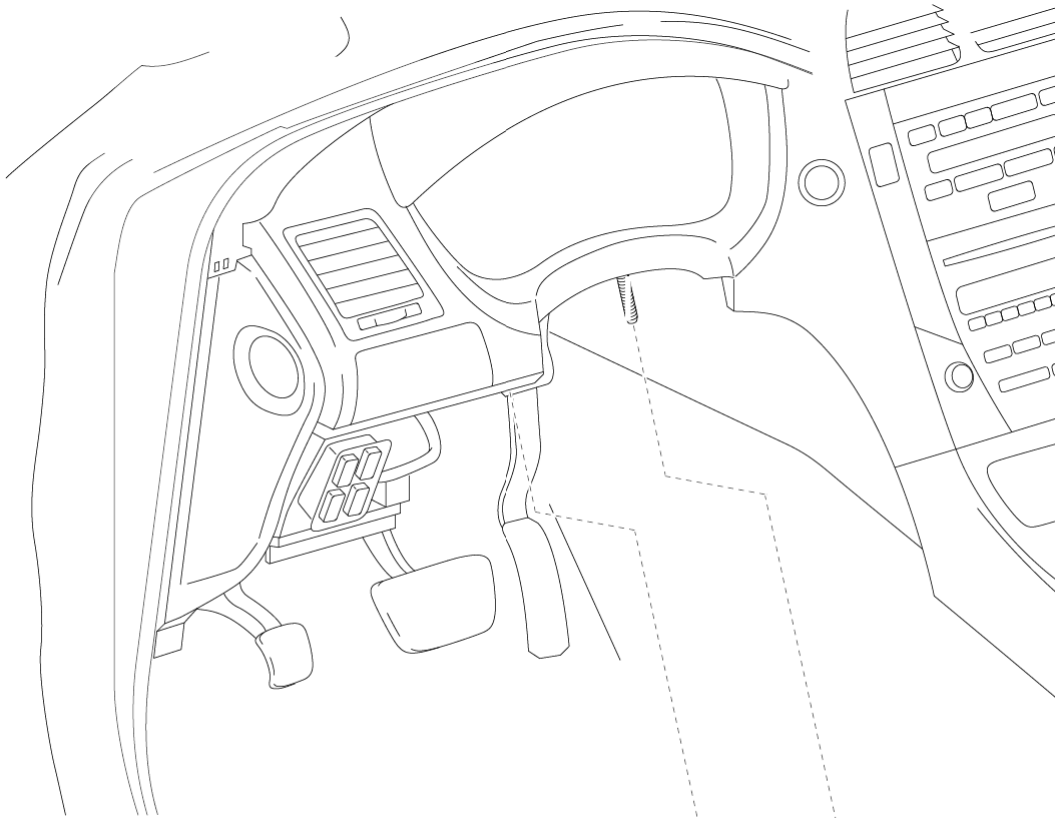

21 (214, 16) : Specified torque

ILLUSTRATION

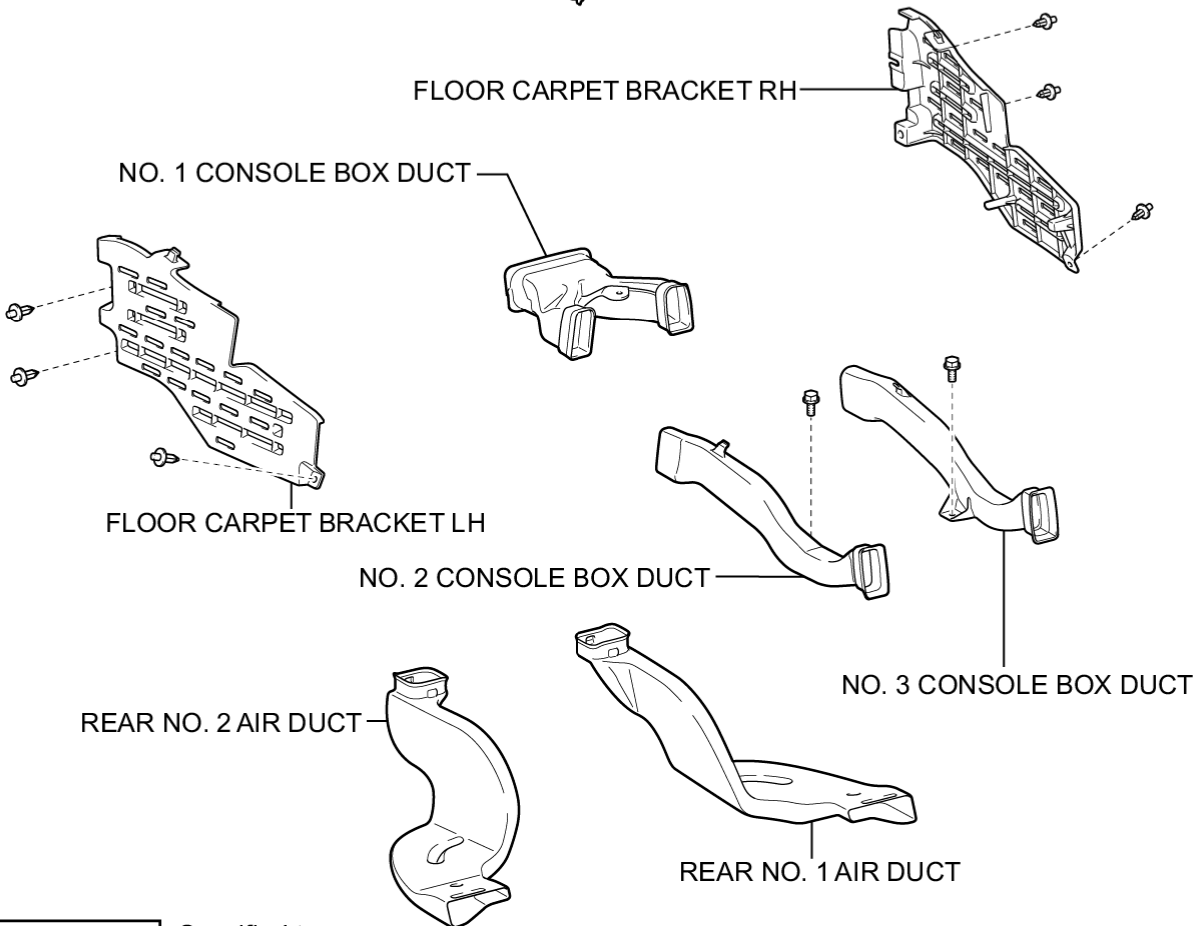
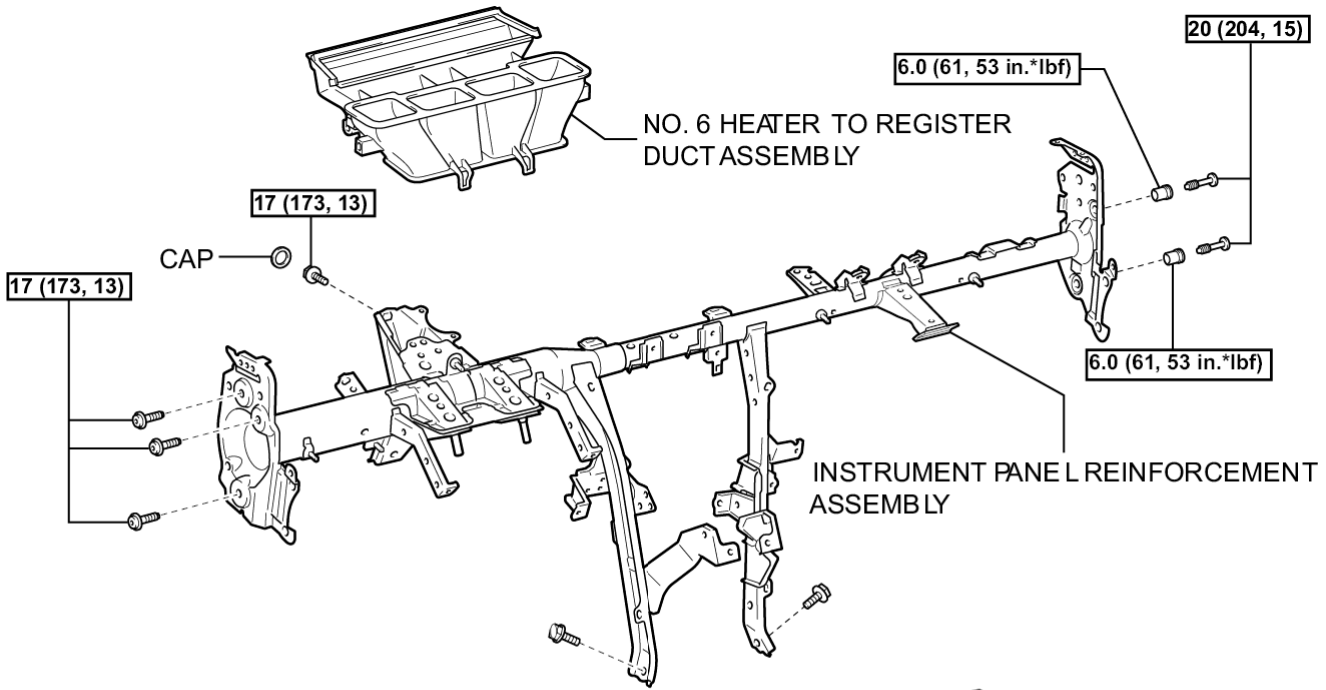

N*m (kgf*cm, ft.*lbf) : Specified torque

P

ILLUSTRATION

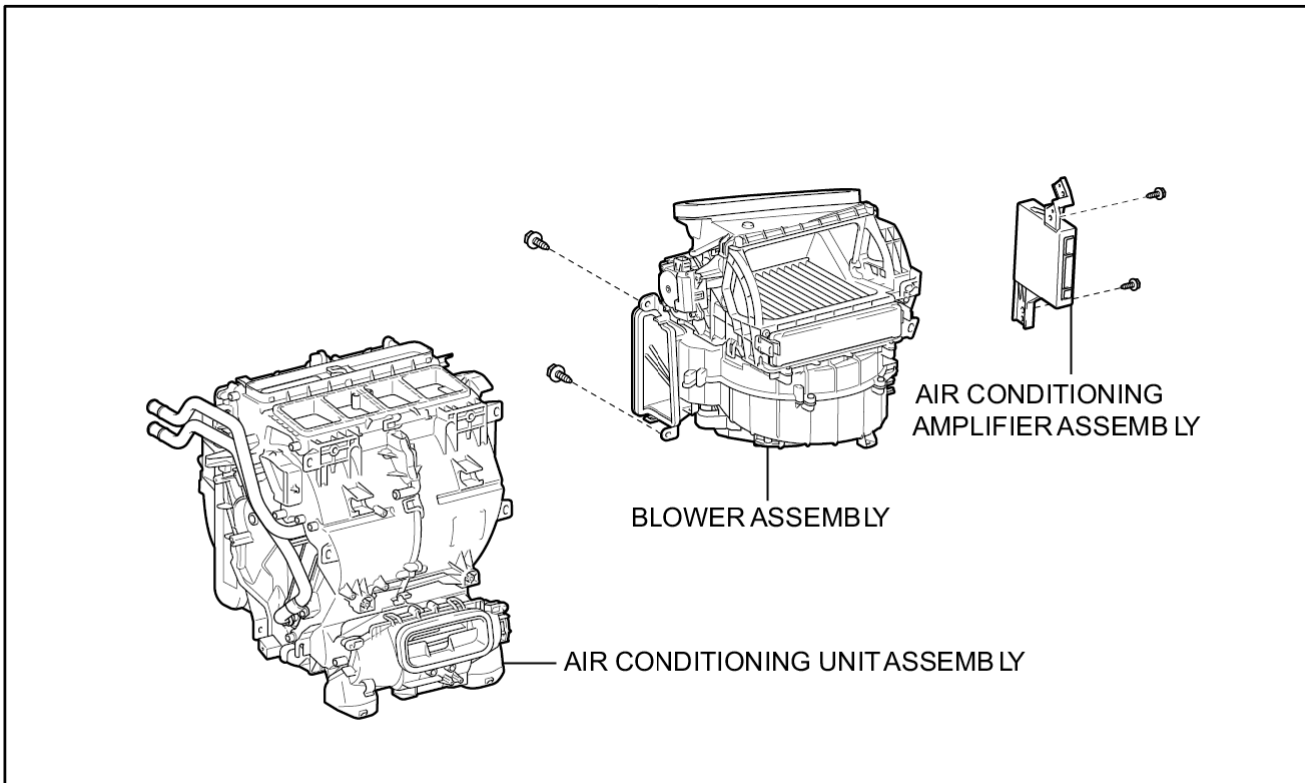
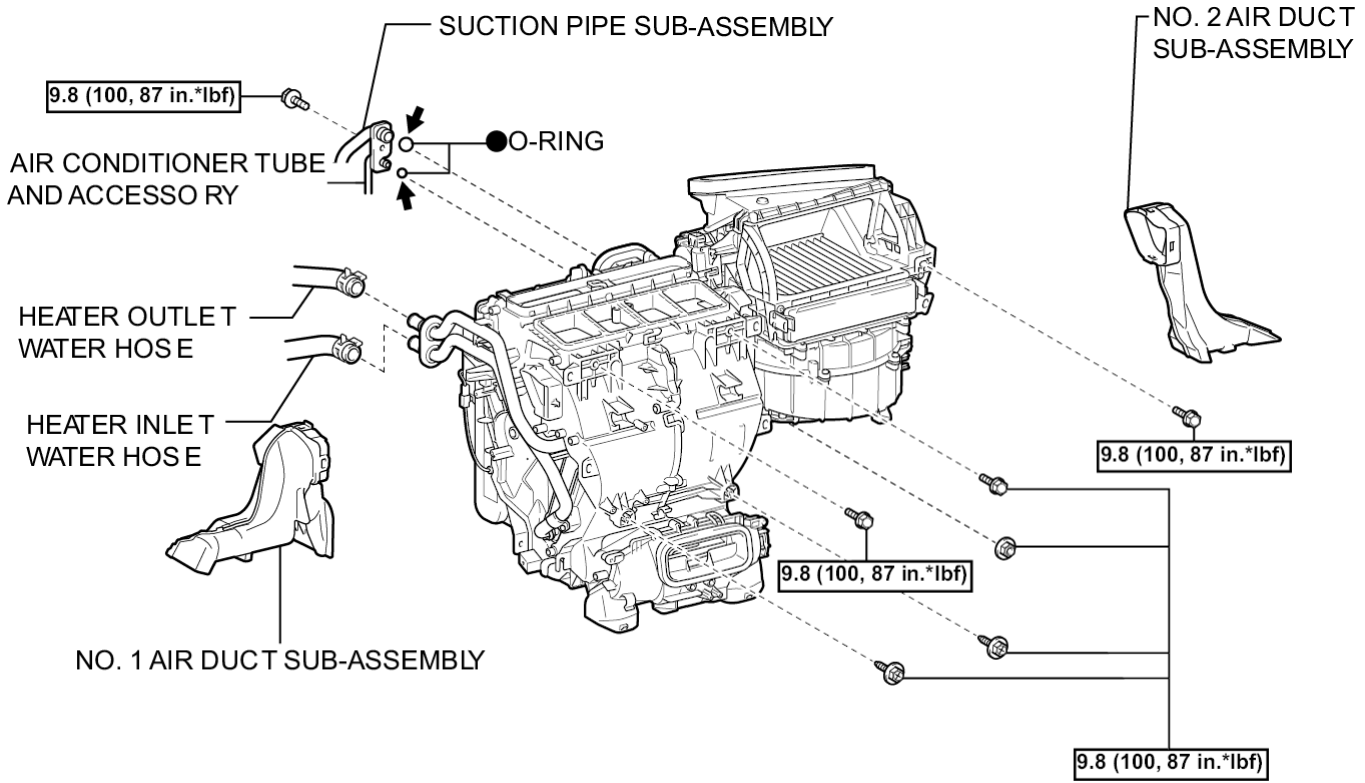

← Compressor oil ND-OIL 8 or equivalent

● Non-reusable part **9.8 (100, 87 in.*lbf)**: Specified torque

P

ILLUSTRATION

