

TERMINAL AND CONNECTOR REPAIR—TERMINAL REPLACEMENT

Step 4. Install the terminal into the connector.

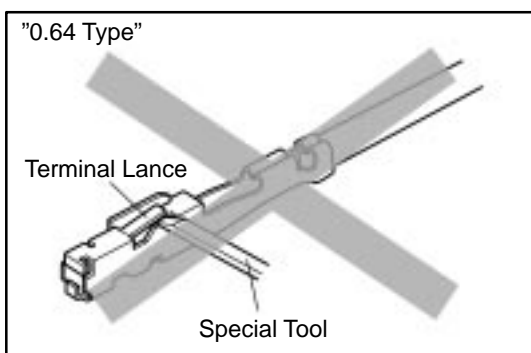
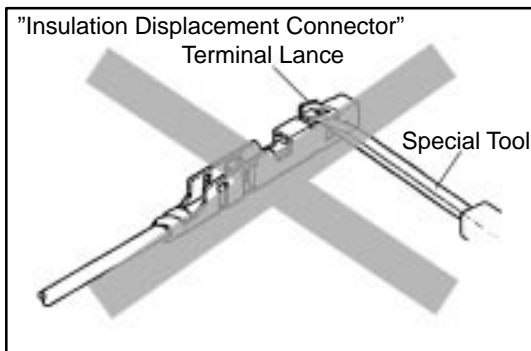
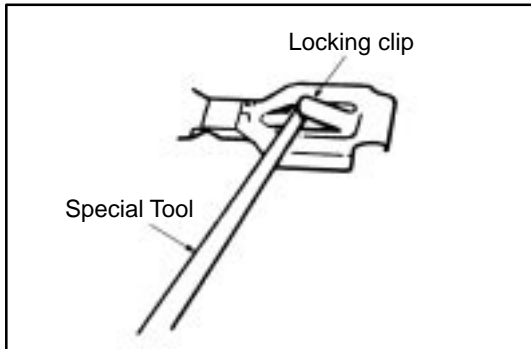
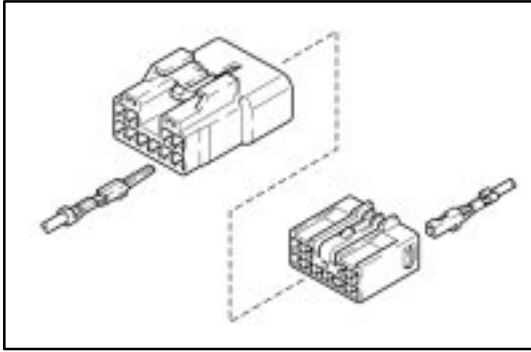

HINT:

- (a) Make sure the terminal is positioned correctly.
- (b) Insert the terminal until the locking clip locks firmly.
- (c) Insert the terminal with terminal retainer in the temporary lock position, if equipped.

NOTE: If reusing a terminal, check that the locking clip is still in good condition and in the proper position.

- (a) If it is on the terminal and not in the proper position, use the special tool to gently bend the locking clip back to the original shape.
- (b) Check that the other parts of the terminal are in their original shape.

NOTICE:

Do not readjust or reuse the terminal lance of the insulation displacement connector type terminal. Always change the wire with the repair wire.

NOTICE:

As for 0.64 type terminal, do not adjust the terminal lance with the special tool.

Splash Proof Type Connector

NOTICE:

- Removal of the terminal from housing cavity will cause damage to rubber plug material (the wire seal), deteriorating waterproofing performance. Be sure to replace the housing with a new one.
- Check the withdrawn terminal for the following if trying to use it again.
 - It is free of deformation and damage
 - It is free of adherents such as rubber plug material (wire seal)
 - Replace any deformed terminal.

TERMINAL AND CONNECTOR REPAIR-TERMINAL REPLACEMENT

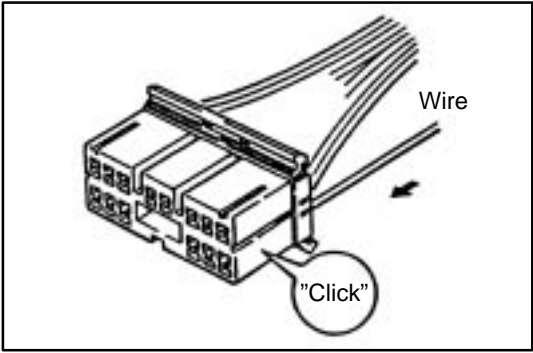

1. Push the Terminal into the Connector until you hear a "click".

NOTE: Not all terminals will give an audible "click".

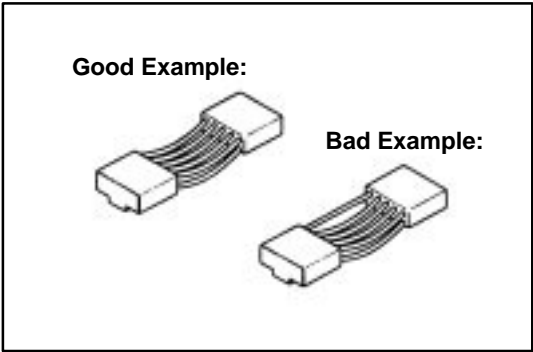
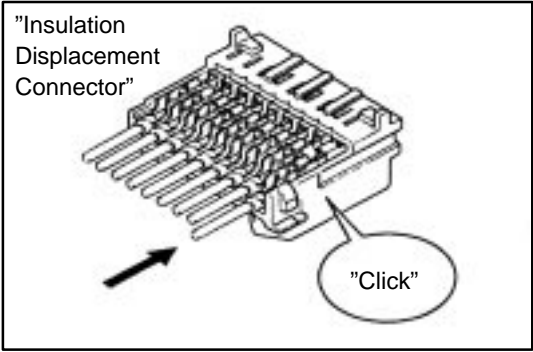
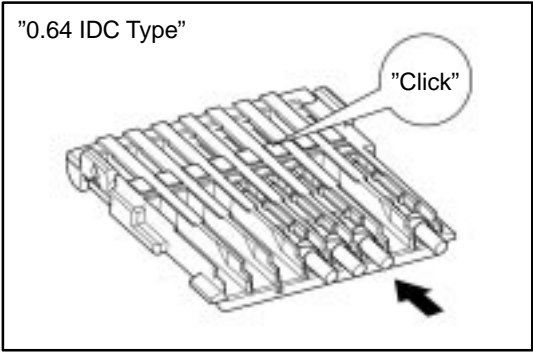

NOTICE:

- After repairing, never let only one harness stretch.
- In case that it becomes short, do over again using the repair wire.

**2. Double Locking Type Connector
(with terminal retainer or double locking device)**

The connector is fitted with a terminal retainer, or a double locking device, it is in the temporary lock position at insert the terminal.

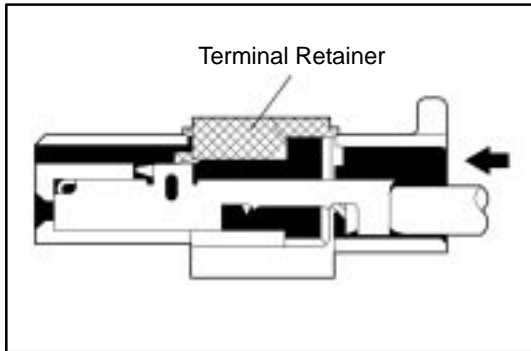

Type A (For 1.0, 1.0II, 1.3, 1.8, 2.3II 4.8 and 8.0 of Non-Waterproof Type Connector)

(a) Insert the terminal.

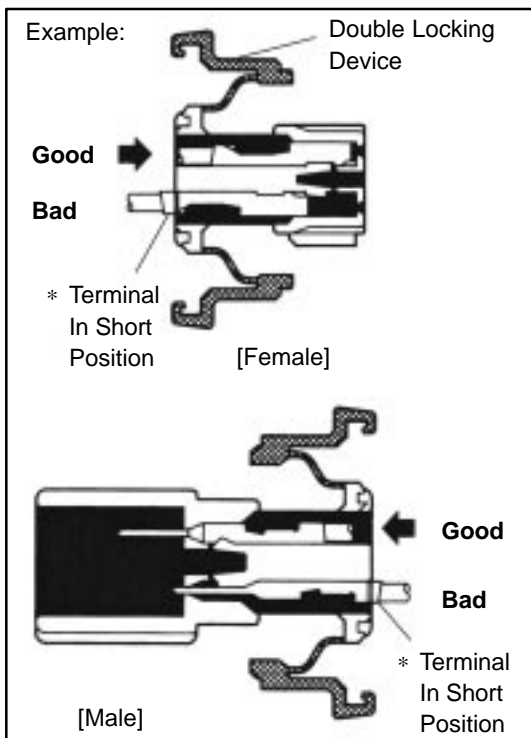

HINT:

1. Make sure the terminal is positioned correctly.
2. Insert the terminal with terminal retainer in the temporary lock position.

(b) Insert the terminal until the locking clip locks firmly.

HINT:

1. Pull the terminal back gently to check whether it is locked correctly.
2. If it cannot be inserted easily, check the terminal and the connector for damage.

NOTE: If the terminal to locking clip does not lock firmly, the double locking device cannot lock or terminal retainer does not lock at full lock position so the terminal backs out from connector.

(c) Close terminal retainer or double locking device.

The connector is fitted with a terminal retainer, or a double locking device, return it to the full lock position.

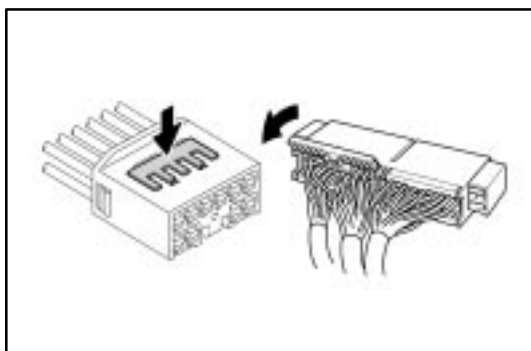

TERMINAL AND CONNECTOR REPAIR-TERMINAL REPLACEMENT

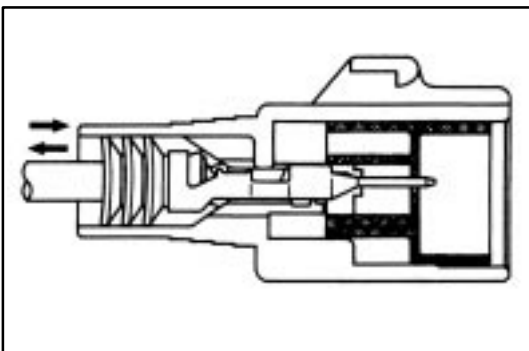
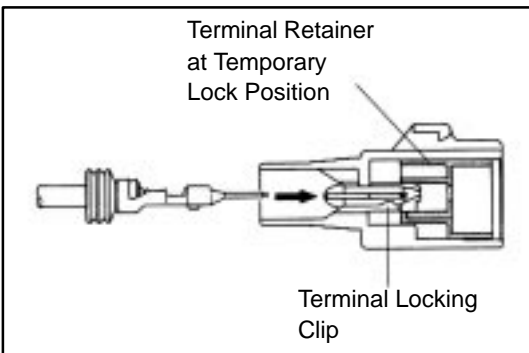
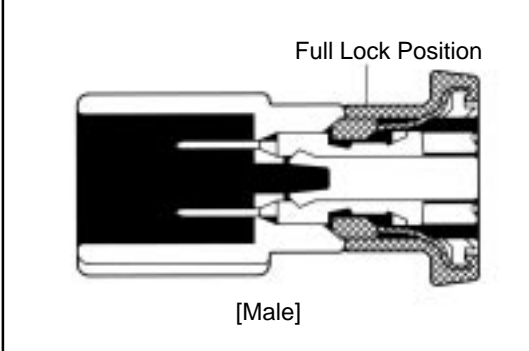
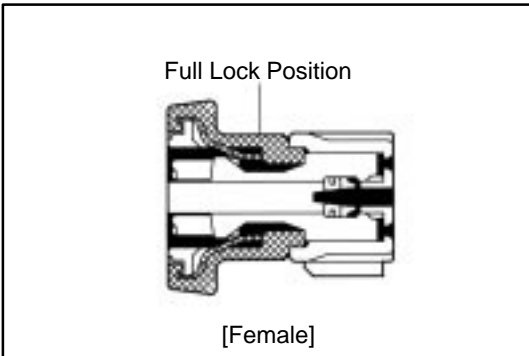
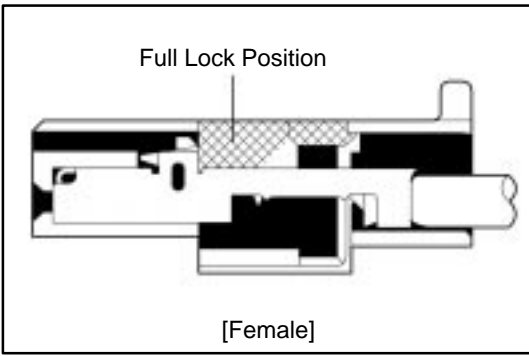

Type B (For 1.8, 2.3, 2.3II, 4.8, 6.3 and 8.0 of Waterproof Type)
(For Male Connector)

(a) Insert the terminal.

HINT:

1. Make sure the terminal is positioned correctly.
2. Insert the terminal with terminal retainer in the temporary lock position.

(b) Insert the terminal until the locking clip locks firmly.

HINT:

1. Pull the terminal back gently to check whether it is locked correctly.
2. If it cannot be inserted easily, check the terminal and the connector for damage.

TERMINAL AND CONNECTOR REPAIR-TERMINAL REPLACEMENT

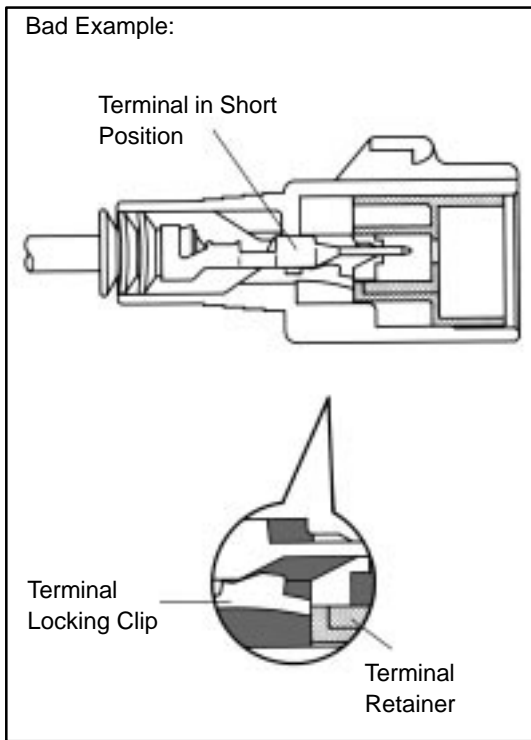

NOTE: If the terminal to locking clip does not lock firmly, terminal retainer can not lock at full lock position so the terminal backs out from connector.

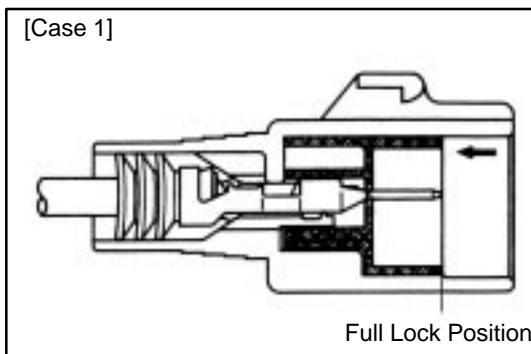

- (c) "For Case 1"
Push the terminal retainer in to the full lock position.

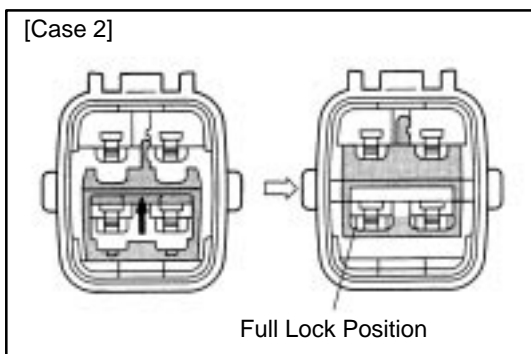

- "For Case 2"
Raise the terminal retainer up to the full lock position.

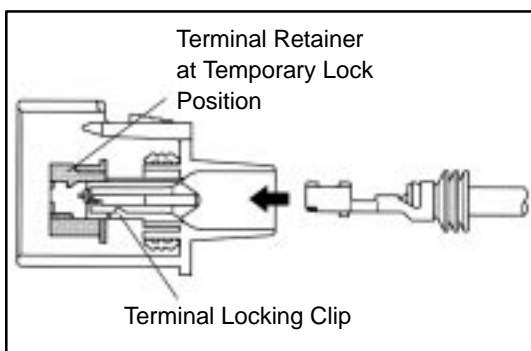

(For Female Connector)

- (a) Insert the terminal.
- HINT:
1. Make sure the terminal is positioned correctly.
 2. Insert the terminal with terminal retainer in the temporary lock position.

TERMINAL AND CONNECTOR REPAIR-TERMINAL REPLACEMENT

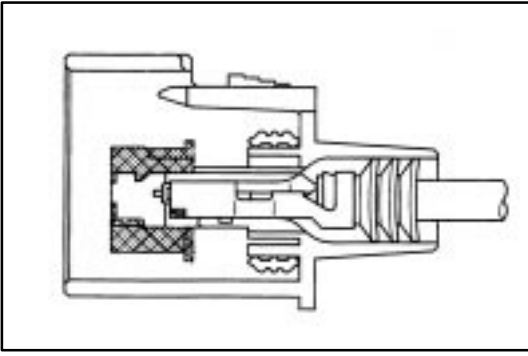

(b) Insert the terminal until the locking clip locks firmly.

HINT:

1. Pull the terminal back gently to check whether it is locked correctly.
2. If it cannot be inserted easily, check the terminal and the connector for damage.

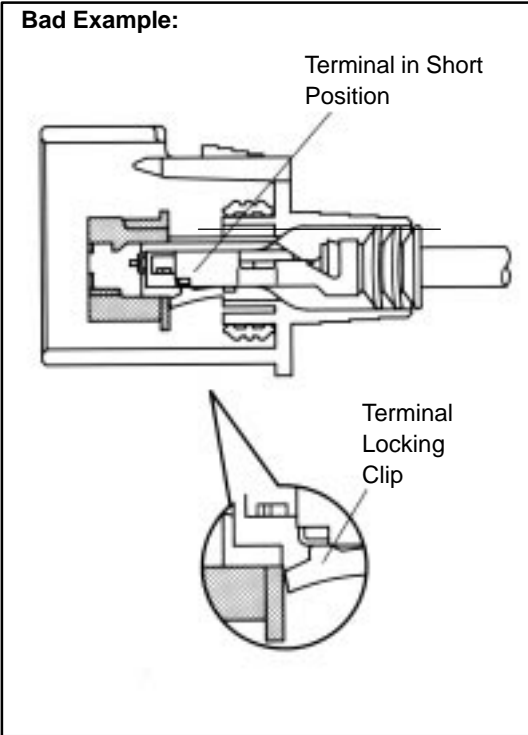

NOTE: If the terminal to locking clip does not lock firmly, terminal retainer can not lock at full lock position so the terminal backs out from connector.

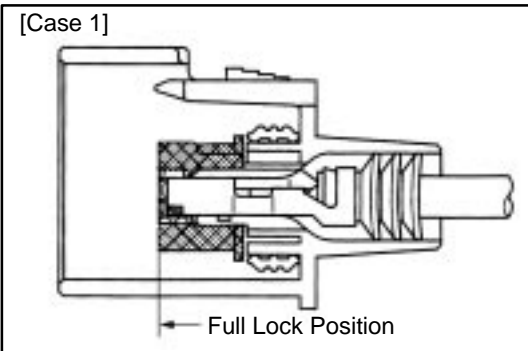

(c) "For Case 1"
Push the terminal retainer in to the full lock position.

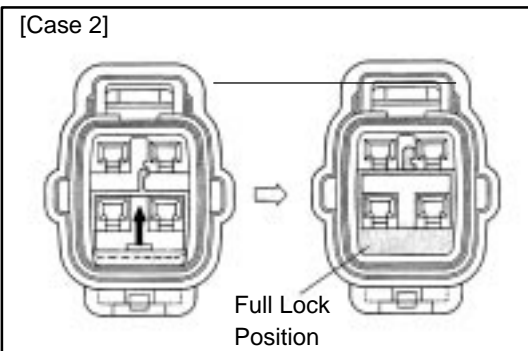

"For Case 2"
Raise the terminal retainer up to the full lock position.

TERMINAL AND CONNECTOR REPAIR—TERMINAL REPLACEMENT

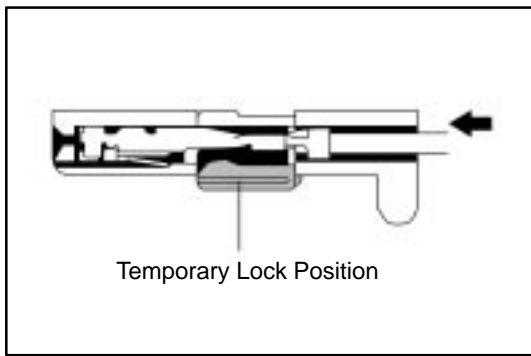

Type C (For 0.64 Type Connector)

- (a) Insert the terminal.

HINT:

1. Make sure the terminal is positioned correctly.
2. Insert the terminal with terminal retainer in the temporary lock position.

- (b) Insert the terminal until the terminal lance locks firmly.

HINT:

1. Pull the terminal back gently to check whether it is locked correctly.
2. If it cannot be inserted easily, check the terminal and the connector for damage.

NOTE: If the terminal to terminal lance does not lock firmly, the double locking device cannot lock or terminal retainer does not lock at full lock position so the terminal backs out from connector.

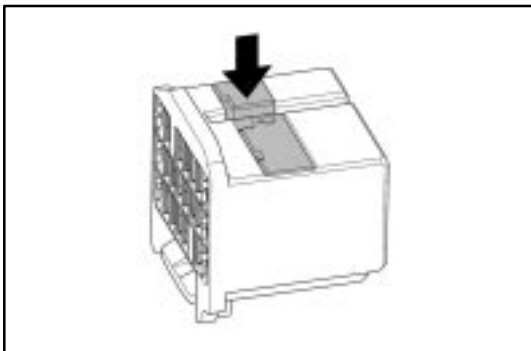

- (c) Close terminal retainer.

The connector is fitted with a terminal retainer, return it to the full lock position.

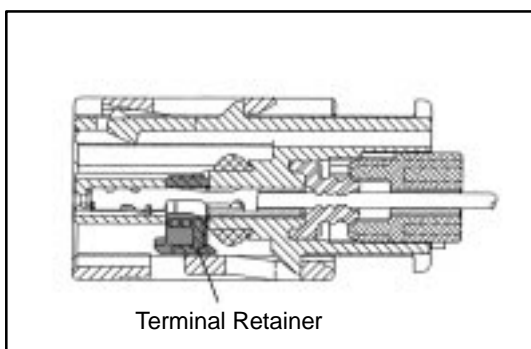
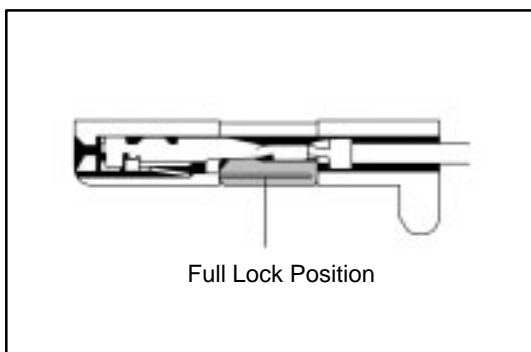

Type D (For 0.64 Splash Proof Type Connector)

- (a) Verify that the terminal retainer is at unlocked position.

TERMINAL AND CONNECTOR REPAIR—TERMINAL REPLACEMENT

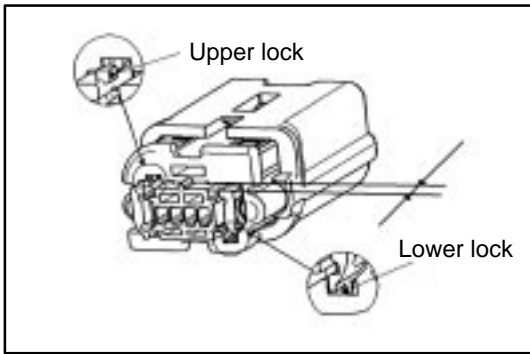

- (b) Verify that Rear Holder is at unlocked position.

NOTICE:

If Rear holder or wire seal has been removed, replace it with new one.

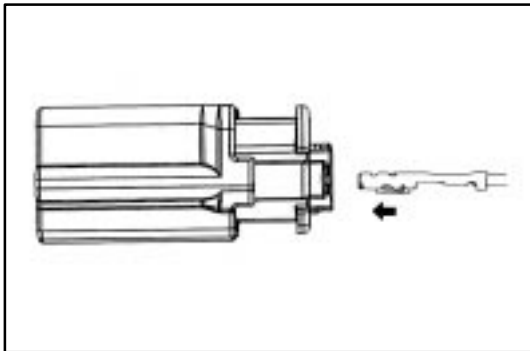

- (c) Insert the terminal fully into the housing until it is locked.

HINT: The terminal has a longer insertion stroke than conventional ones.

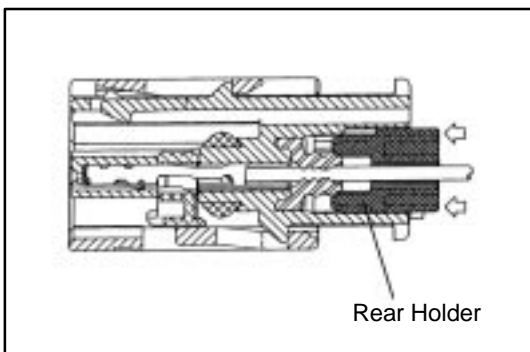

- (d) Set Rear holder to locked position. Push Rear holder in the direction of arrow until it is locked.

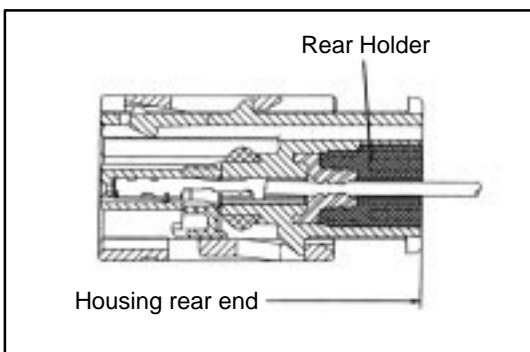

- (e) Verify that Rear holder is at the specified position. The rear end of Rear holder is flush with the rear end of Housing.

TERMINAL AND CONNECTOR REPAIR-TERMINAL REPLACEMENT

Verify that the lock (upper side) is at the specified position under locked status.

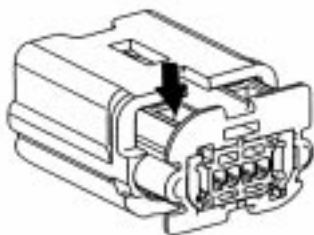

Lock check position, upper

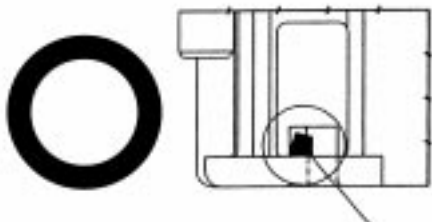

Lock normal engagement position

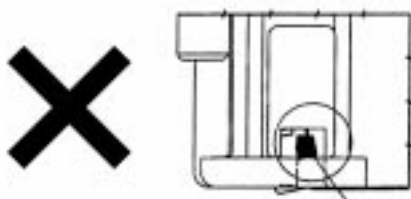

Incomplete lock engagement

TERMINAL AND CONNECTOR REPAIR-TERMINAL REPLACEMENT

Verify that the lock (lower side) is at the specified position under the locked status.

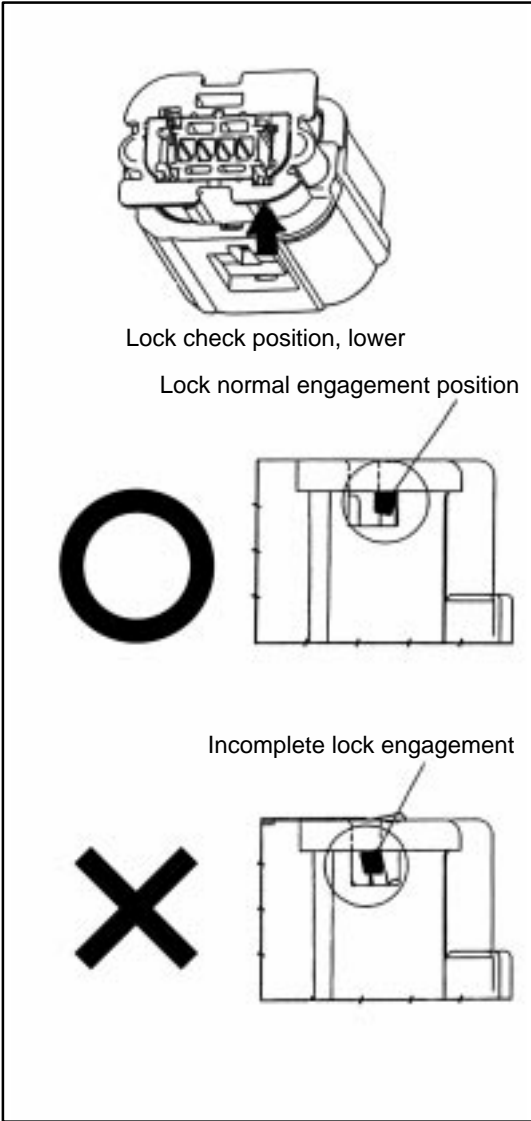

- (f) Set Terminal retainer to Lock position. Insert Special tool into the hole specified in the left and push Terminal retainer.

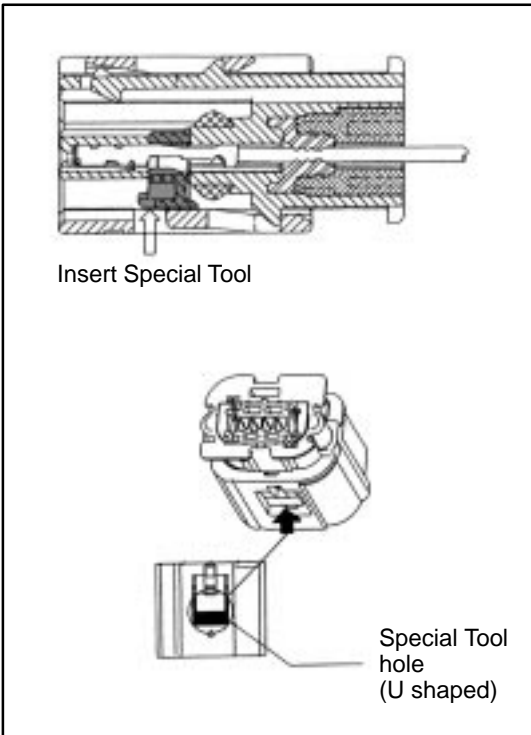

TERMINAL AND CONNECTOR REPAIR—TERMINAL REPLACEMENT

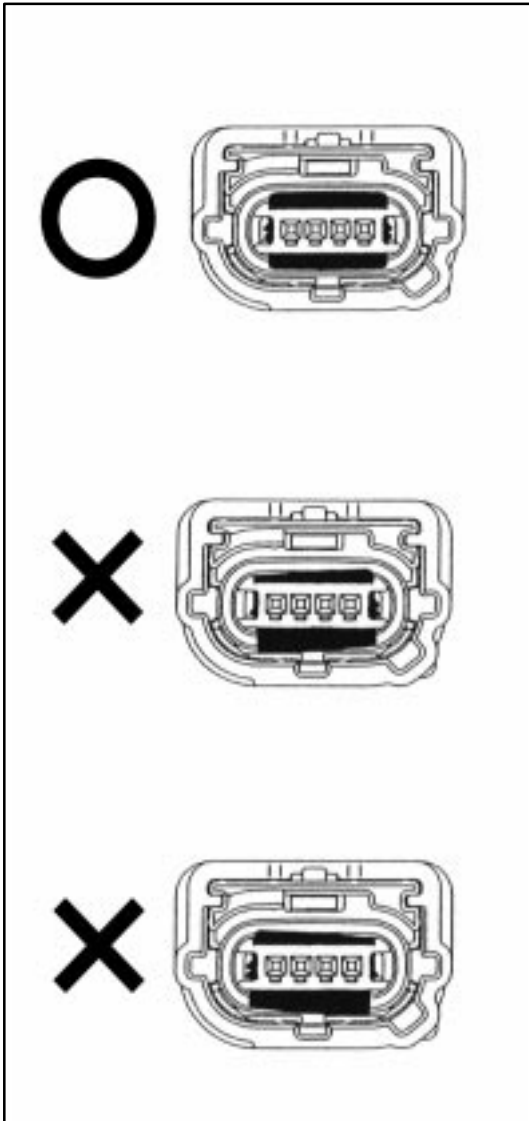

- (g) Verify that Terminal retainer is inserted to the specified position.

NOTICE:

If Terminal retainer is stopped at its middle of insertion, holding wire, push Terminal to help it for full insertion.

TERMINAL AND CONNECTOR REPAIR-TERMINAL REPLACEMENT

SPECIAL EXAMPLE

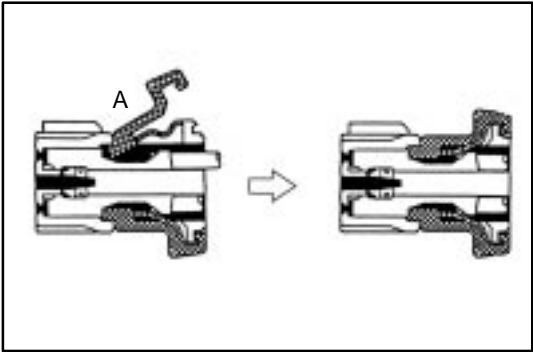

- First fit the section A.

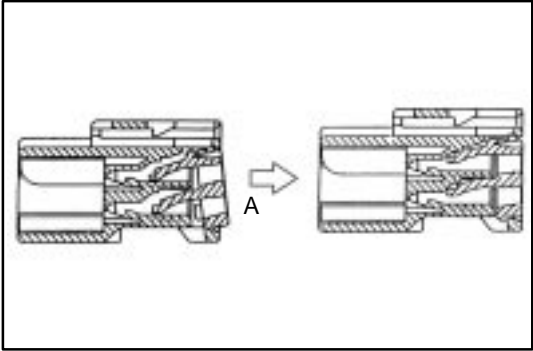

- Install the lock of the section A first.

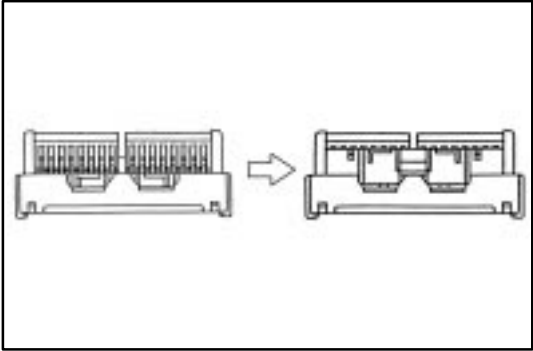

- Install the lock of the retainer and pull the white cover until you hear a click sound.

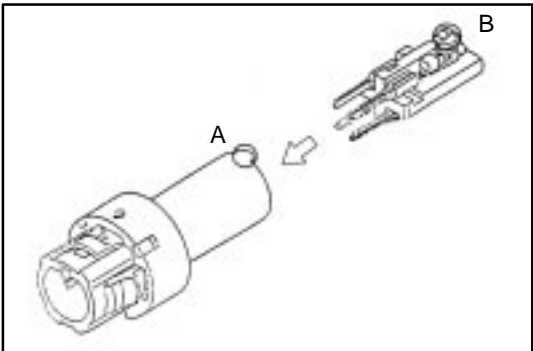

- Install the convex part (A) of the outer part correctly to the section B of the inner part.

TERMINAL AND CONNECTOR REPAIR—TERMINAL REPLACEMENT

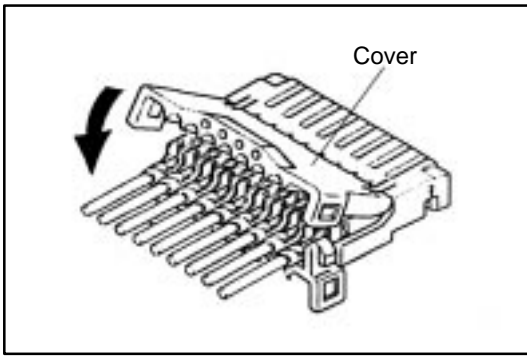

Insulation Displacement Connector

w/ Cover : **CLOSE COVER**

NOTICE:
Securely lock it

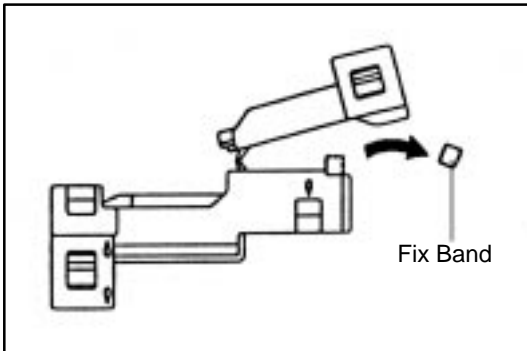

HINT:

When replacing it to a new connector, cut off the fixing band without leaving it.

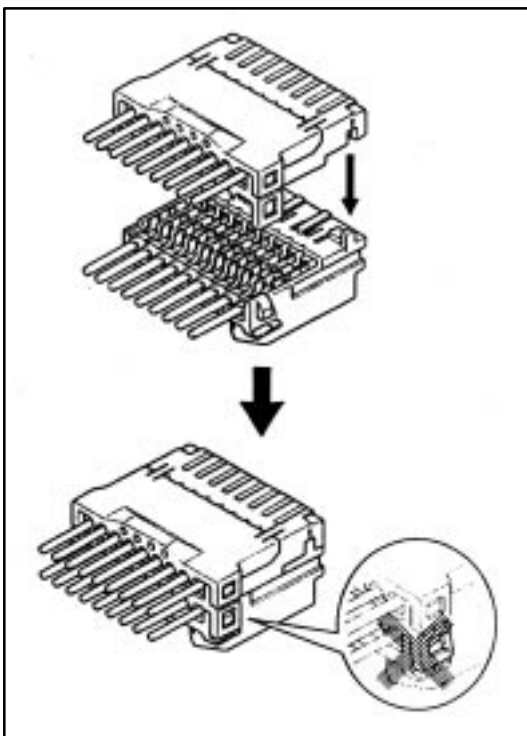

UNITE CONNECTOR

Make the projection of the front lock of the upper housing meet the ditch of the front lock of the lower housing and fix the rear lock.

NOTICE:

- After uniting, securely lock it for not leaving the rear lock arm deformed.
- Make sure that the terminals will not become loose by pulling the wires lightly.

TERMINAL AND CONNECTOR REPAIR—TERMINAL REPLACEMENT

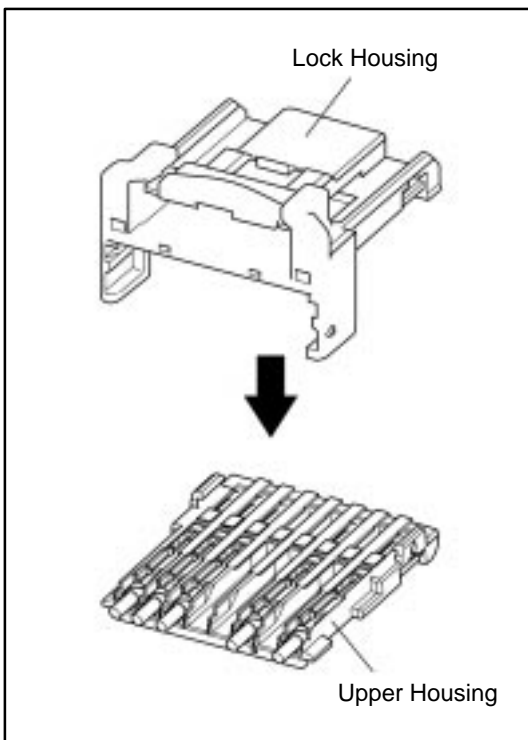

Insulation Displacement Connector (0.64 Type)

(a) Install the upper housing to the lock housing.

NOTICE:

- Securely Lock it.
- Be careful not to mistake the upper housing and lower housing when putting together.

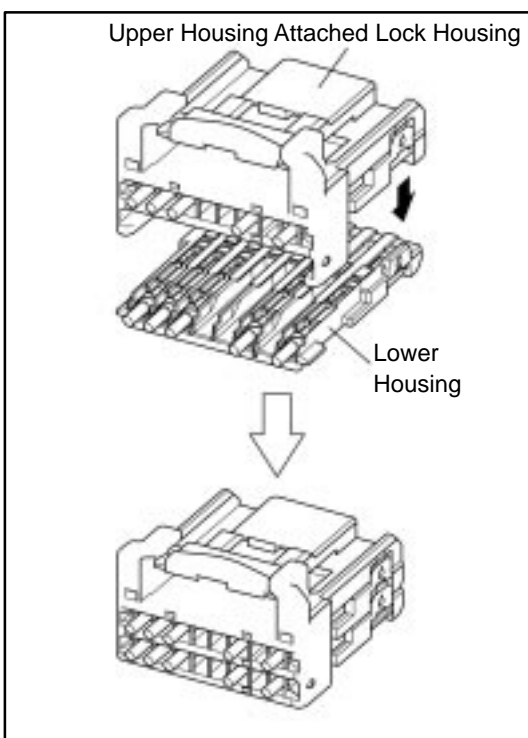

(b) Make the projection of the front lock of the upper housing attached lock housing meet the ditch of the front lock of the lower housing and fix the rear lock.

NOTICE:

- After uniting, securely lock it for not leaving the rear lock arm deformed.
- Make sure that the terminals will not become loose by pulling the wires lightly.
- Be careful not to mistake the upper housing and lower housing when putting together.

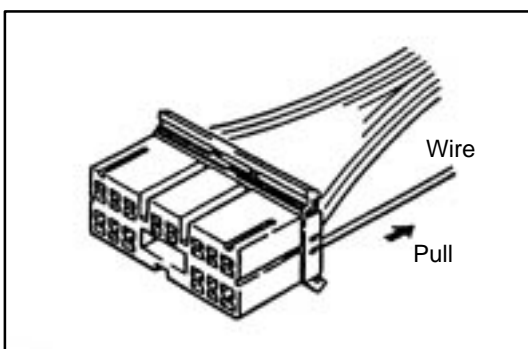

3. When properly installed, pulling gently on the wire lead will prove the terminal is locked in the connector.

TERMINAL AND CONNECTOR REPAIR—TERMINAL REPLACEMENT

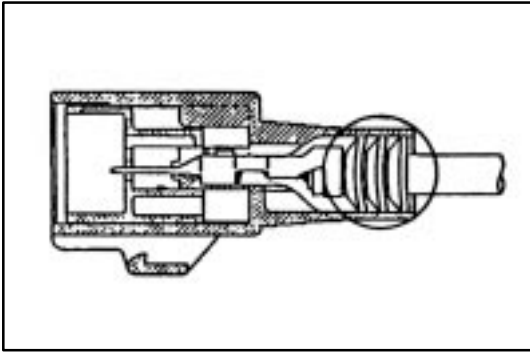
**NOTICE:**

If you working on the waterproof type, make sure that a rubber plug or a terminal gasket is inserted into the housing securely.

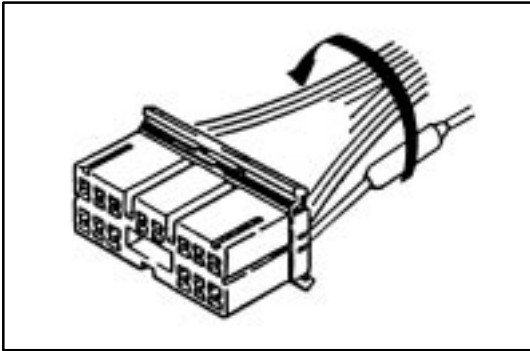
**4. Secure the Repaired Wire to the Harness**

If the wire is not in the conduit, or secured by other means, wrap vinyl tape around the bundle to keep it together with the other wires.

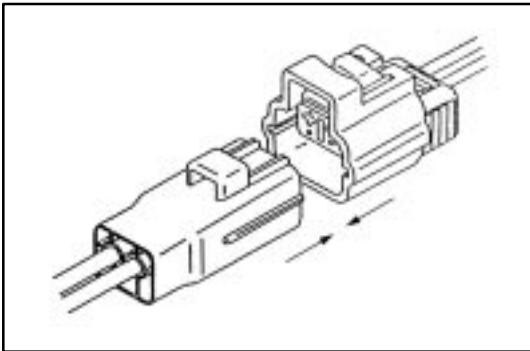
**5. Connect Connector**

- Fit the male connector to the female terminal.

NOTICE:

- Do not twist the connector when fitting.
- Insert it until fully locked.