

Last Modified: 7-13-2007		1.6 A
Service Category: Vehicle Exterior	Section: Exterior Panels/Trim	
Model Year: 2008	Model: ES350	Doc ID: RM000002D5F002X
Title: EXTERIOR: LUGGAGE COMPARTMENT DOOR GARNISH: REMOVAL (2008 ES350)		

REMOVAL

1. REMOVE LUGGAGE COMPARTMENT DOOR ASSIST GRIP

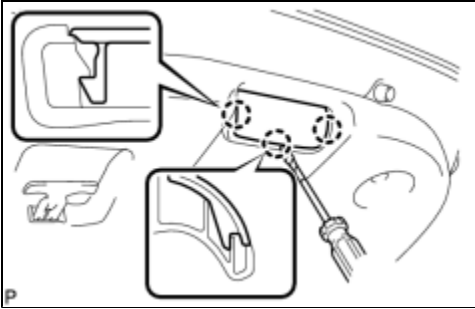

(a) Using a screwdriver, disengage the 3 claws and open the assist grip cover.

HINT:

Tape the screwdriver tip before use.

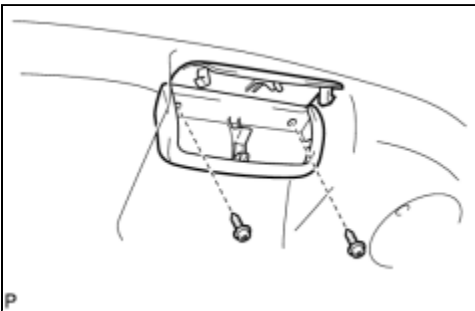

(b) Remove the 2 screws and luggage compartment door assist grip.

2. REMOVE LUGGAGE LOCK CONTROL CABLE PLATE

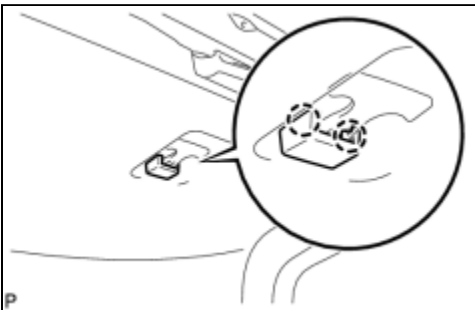

(a) Disengage the 2 claws and remove the luggage lock control cable plate.

3. REMOVE LUGGAGE COMPARTMENT DOOR INSIDE HANDLE

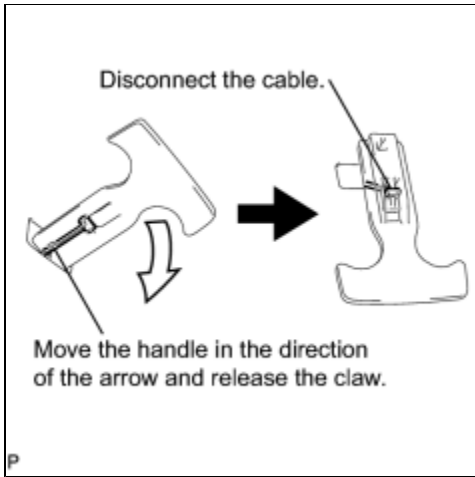

(a) Disconnect the cable as shown in the illustration, then remove the luggage compartment door inside handle.

4. REMOVE LUGGAGE COMPARTMENT DOOR COVER

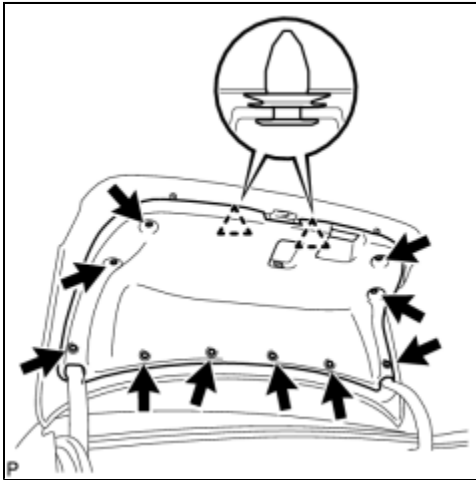

(a) Using a clip remover, remove the 10 clips.

(b) Disengage the 2 clips and luggage compartment door cover.

5. REMOVE REAR LIGHT ASSEMBLY LH INFO

6. REMOVE REAR LIGHT ASSEMBLY RH

7. REMOVE LUGGAGE DOOR OPENING SWITCH ASSEMBLY INFO

8. REMOVE LUGGAGE COMPARTMENT DOOR OUTSIDE GARNISH SUB-ASSEMBLY (w/o Rear View Monitor System)

(a) Put protective tape around the luggage compartment door outside garnish sub-assembly.

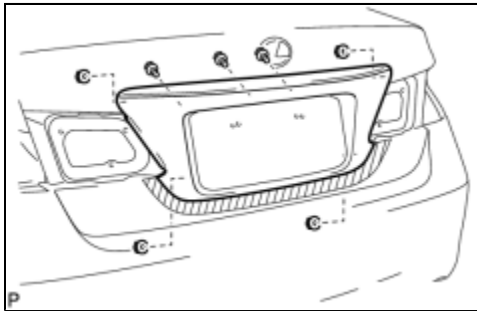
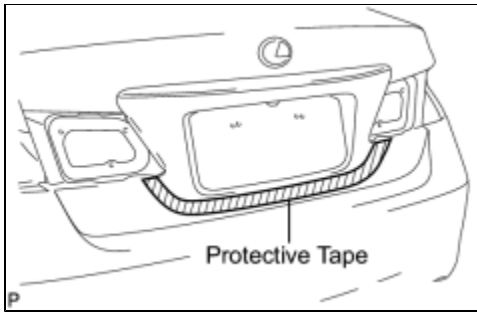

(b) Remove the 3 bolts and 4 nuts.

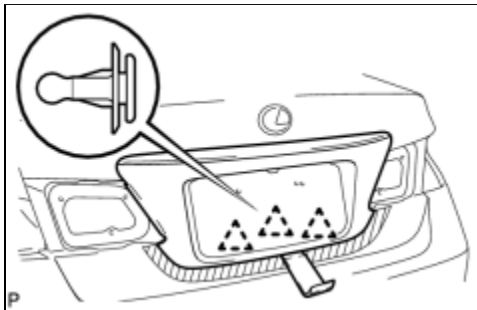

(c) Using a moulding remover, disengage the 3 clips and remove the luggage compartment door outside garnish sub-assembly.

9. REMOVE TELEVISION CAMERA ASSEMBLY (w/ Rear View Monitor System)



10. REMOVE LUGGAGE COMPARTMENT DOOR OUTSIDE GARNISH SUB-ASSEMBLY (w/ Rear View Monitor System)

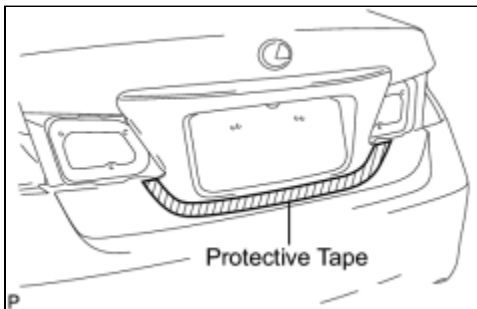

(a) Put protective tape around the luggage compartment door outside garnish sub-assembly.

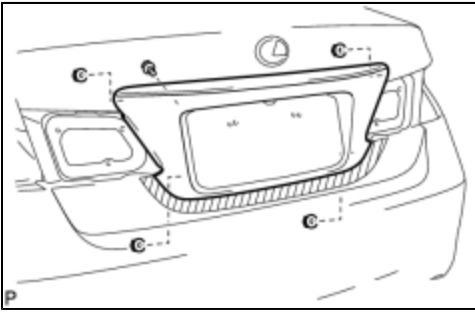

(b) Remove the bolt and 4 nuts.

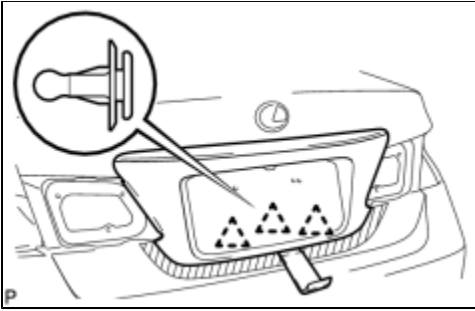

(c) Using a moulding remover, disengage the 3 clips and remove the luggage compartment door outside garnish sub-assembly.

