

Last Modified: 7-13-2007		1.7 A
Service Category: Vehicle Interior	Section: Interior Panels/Trim	
Model Year: 2008	Model: ES350	Doc ID: RM000002DMF002X
Title: INSTRUMENT PANEL: INSTRUMENT PANEL SAFETY PAD: DISASSEMBLY (2008 ES350)		

DISASSEMBLY

1. REMOVE SIDE NO. 1 DEFROSTER NOZZLE DUCT

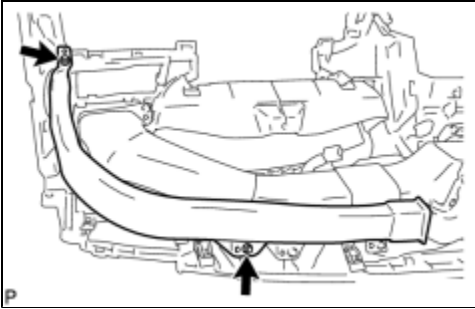

(a) Remove the 2 screws <F> and the side No. 1 defroster nozzle duct.

2. REMOVE SIDE NO. 2 DEFROSTER NOZZLE DUCT

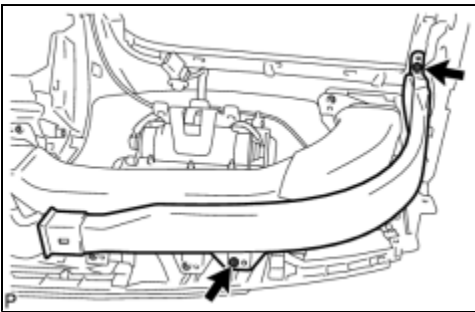

(a) Remove the 2 screws <F> and the side No. 2 defroster nozzle duct.

3. REMOVE DEFROSTER NOZZLE ASSEMBLY

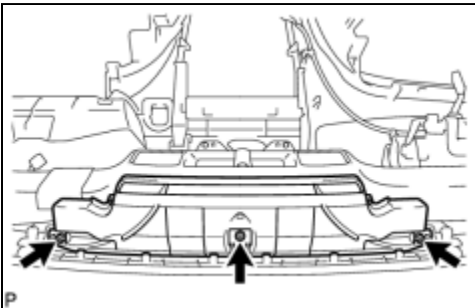

(a) Remove the 3 screws <F> and the defroster nozzle assembly.

4. REMOVE NO. 1 HEATER TO REGISTER DUCT

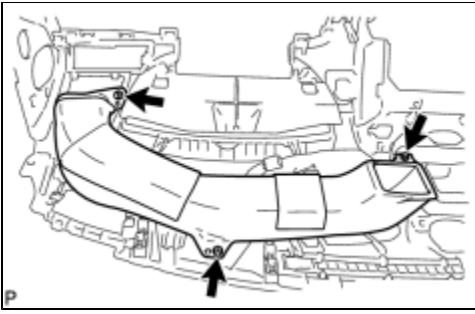

(a) Remove the 3 screws <F> and the No. 1 heater to register duct.

5. REMOVE NO. 2 HEATER TO REGISTER DUCT

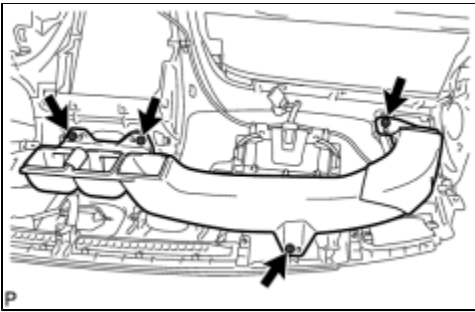

(a) Remove the 4 screws <F> and the No. 2 heater to register duct.

6. REMOVE NO. 2 ANTENNA CORD SUB-ASSEMBLY INFO

7. REMOVE NO. 3 INSTRUMENT PANEL WIRE

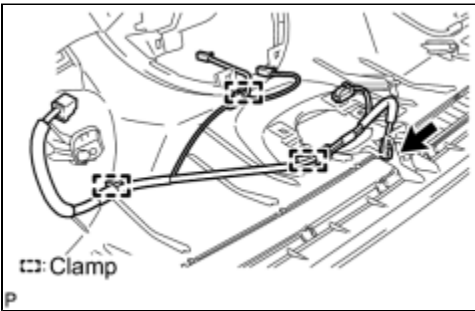

(a) Disconnect the connector.

(b) Disengage the 3 clamps and remove the No. 3 instrument panel wire.

8. REMOVE NAVIGATION ANTENNA ASSEMBLY INFO

9. REMOVE AUTOMATIC LIGHT CONTROL SENSOR

(a) Disengage the 2 claws and remove the automatic light control sensor.

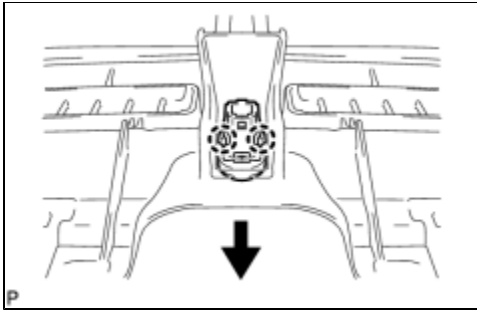

10. REMOVE NO. 1 METER HOOD RETAINER

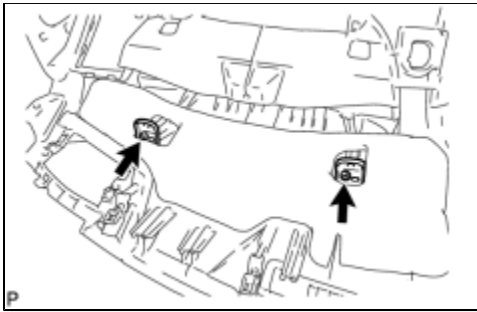

(a) Remove the 2 screws <I> and the 2 No. 1 meter hood retainer.

11. REMOVE FRONT PASSENGER AIRBAG ASSEMBLY [INFO](#)

12. REMOVE NO. 1 INSTRUMENT PANEL PIN

(a) Remove the 4 screws <I> and the 4 No. 1 instrument panel pins.

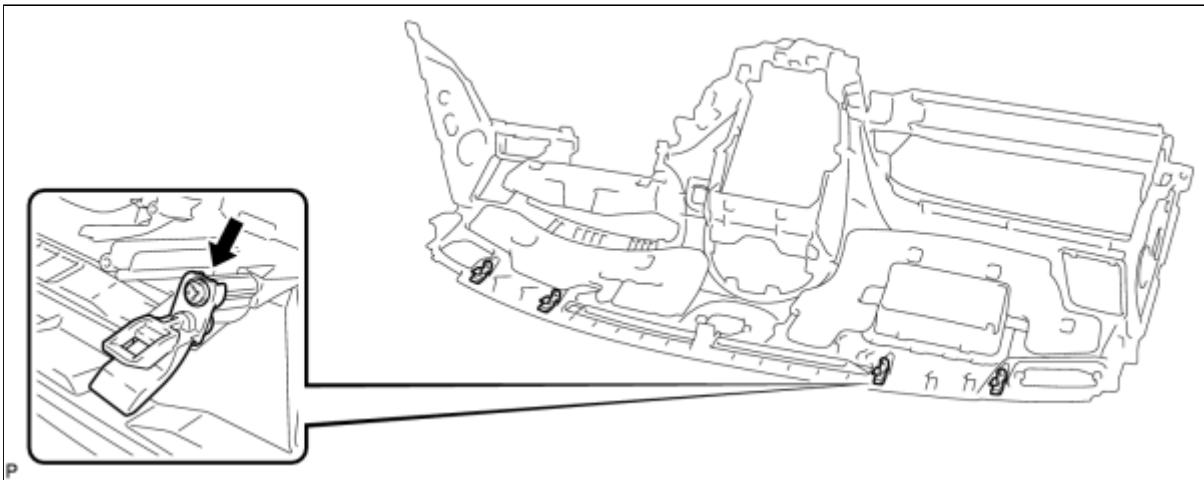

13. REMOVE NO. 1 DEFROSTER NOZZLE GARNISH

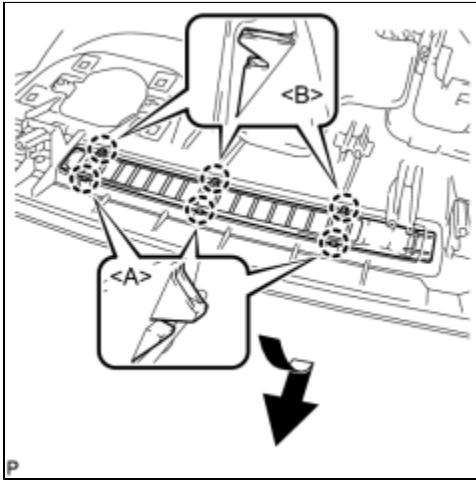

(a) Disengage the 3 claws <A>.

(b) Disengage the 3 claws and remove the No. 1 defroster nozzle garnish as shown in the illustration.

14. REMOVE NO. 2 DEFROSTER NOZZLE GARNISH

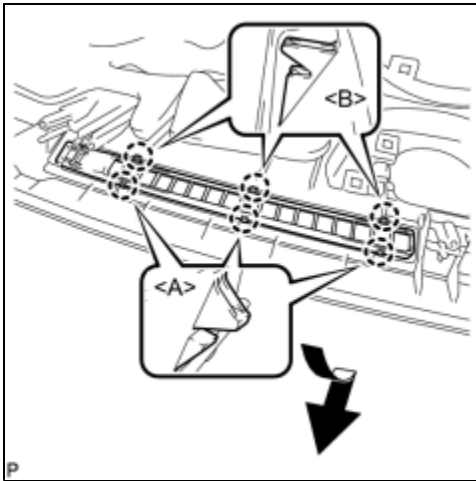

(a) Disengage the 3 claws <A>.

(b) Disengage the 3 claws and remove the No. 2 defroster nozzle garnish as shown in the illustration.

