

### 4. Layout of Main Components

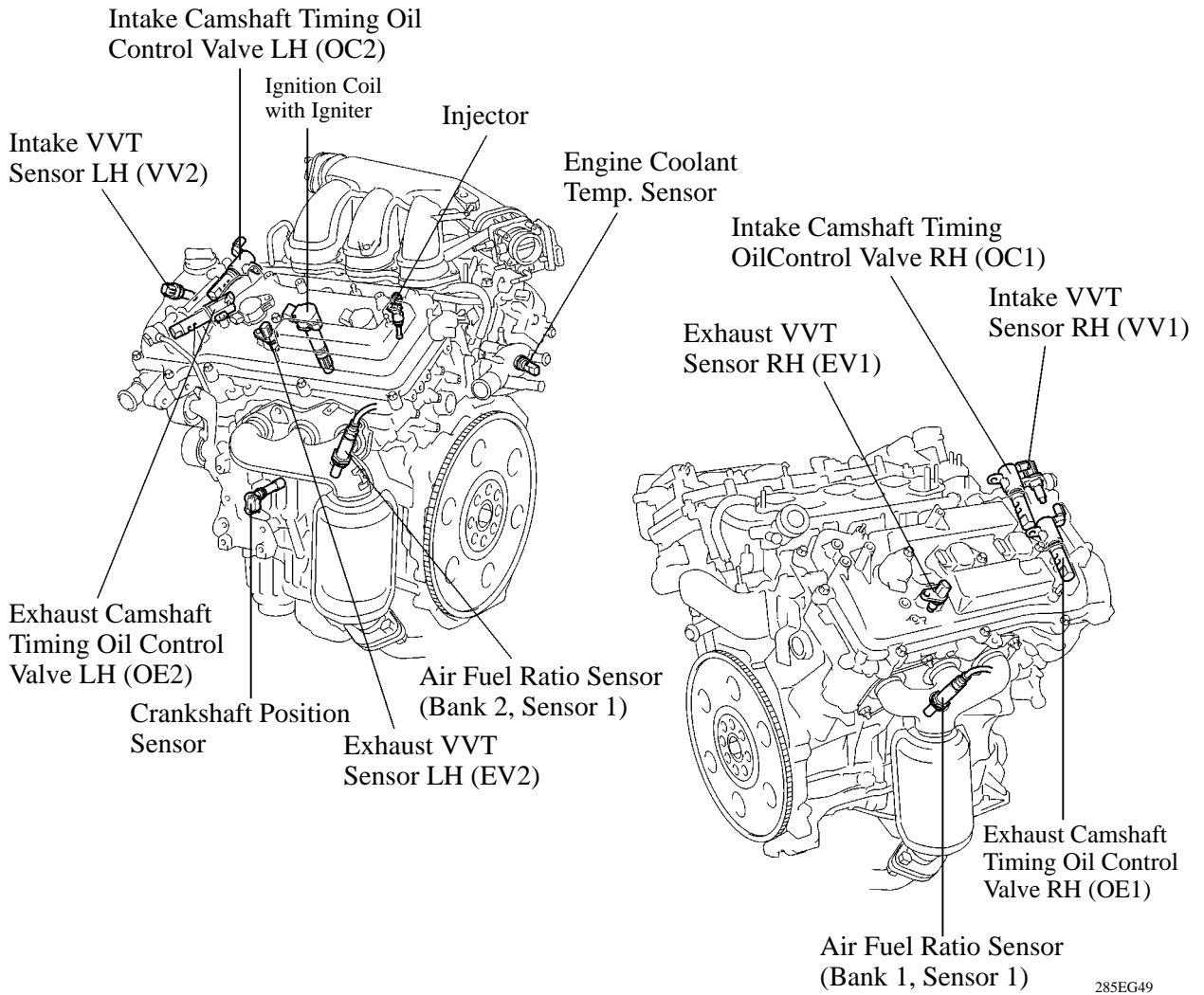

285EG49

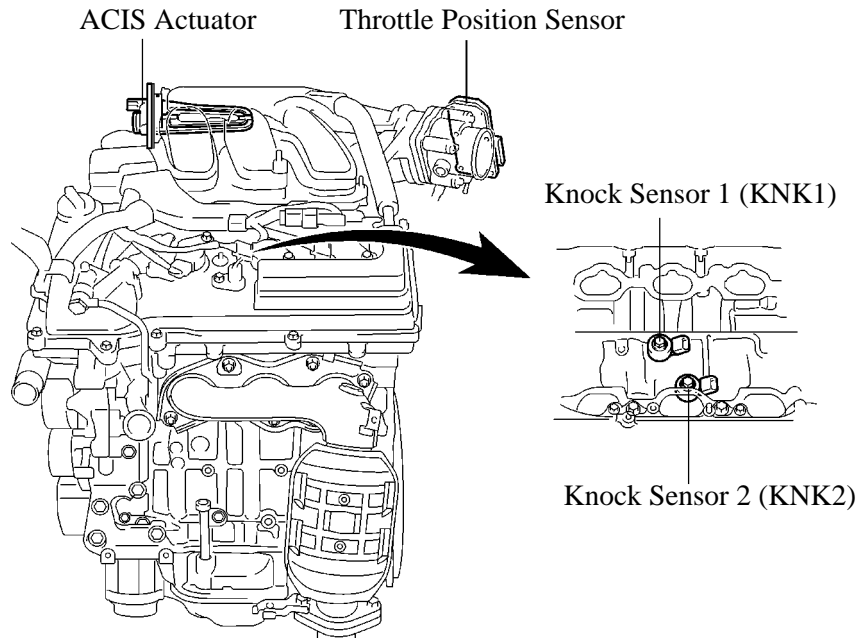

285EG50

