

Last Modified: 7-13-2007		1.6 A
Service Category: Engine/Hybrid System	Section: Cooling	
Model Year: 2008	Model: ES350	Doc ID: RM0000011QD010X
Title: 2GR-FE COOLING: RADIATOR: REMOVAL (2008 ES350)		

REMOVAL

1. REMOVE FRONT WHEEL OPENING EXTENSION PAD LH
2. REMOVE FRONT WHEEL OPENING EXTENSION PAD RH
3. REMOVE ENGINE UNDER COVER LH
4. REMOVE ENGINE UNDER COVER RH
5. DRAIN ENGINE COOLANT [INFO](#)
6. REMOVE V-BANK COVER SUB-ASSEMBLY [INFO](#)
7. REMOVE COOL AIR INTAKE DUCT SEAL [INFO](#)
8. REMOVE ENGINE ROOM SIDE COVER LH
9. REMOVE ENGINE ROOM SIDE COVER RH
10. REMOVE AIR CLEANER CAP SUB-ASSEMBLY [INFO](#)
11. REMOVE AIR CLEANER INLET SUB-ASSEMBLY [INFO](#)
12. REMOVE NO. 1 AIR CLEANER INLET [INFO](#)
13. REMOVE FRONT BUMPER ASSEMBLY [INFO](#)
14. REMOVE FRONT BUMPER ENERGY ABSORBER [INFO](#)
15. REMOVE MILLIMETER WAVE RADAR SENSOR ASSEMBLY (w/ Dynamic Radar Cruise Control System)
16. SEPARATE RADIATOR RESERVE TANK HOSE

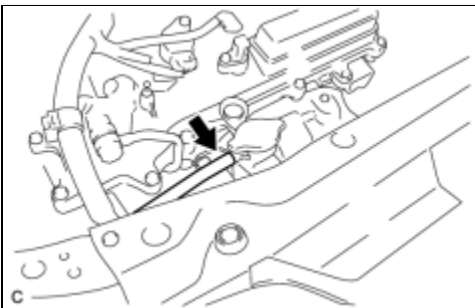

(a) Separate the radiator reserve tank hose from the radiator assembly.

17. DISCONNECT RADIATOR HOSE INLET

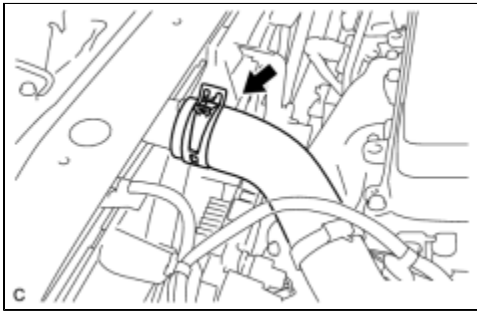

(a) Separate the radiator hose inlet from the radiator assembly.

18. DISCONNECT RADIATOR HOSE OUTLET

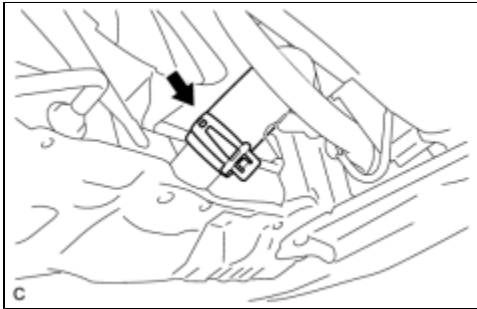

(a) Separate the radiator hose outlet from the radiator assembly.

19. DISCONNECT NO. 1 OIL COOLER INLET HOSE

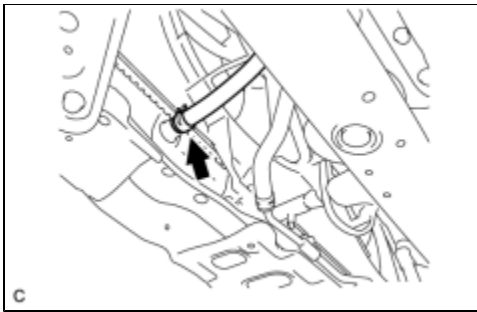

(a) Separate the No. 1 oil cooler inlet hose from the radiator assembly.

20. DISCONNECT NO. 1 OIL COOLER OUTLET HOSE

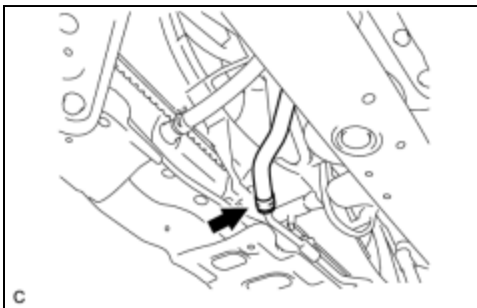

(a) Separate the No. 1 oil cooler outlet hose from the radiator assembly.

21. REMOVE RADIATOR SUPPORT UPPER

(a) Disconnect the horn connectors.

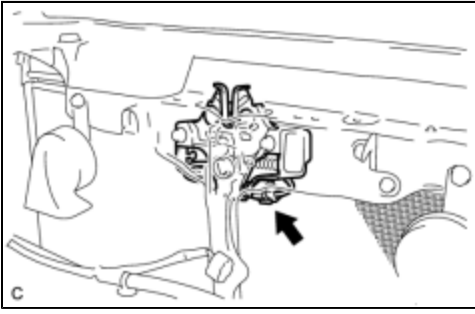

(b) Disconnect the connector.

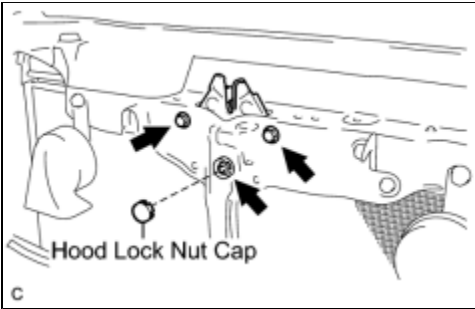

(c) Using a screwdriver, remove the hood lock nut cap.

(d) Remove the 2 bolts and nut, and separate the hood lock assembly from the radiator support upper.

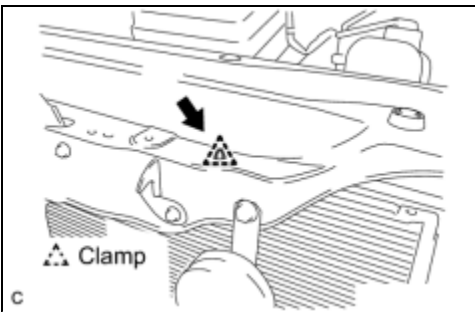

(e) Remove the clamp and separate the hood lock control cable from the radiator support upper.

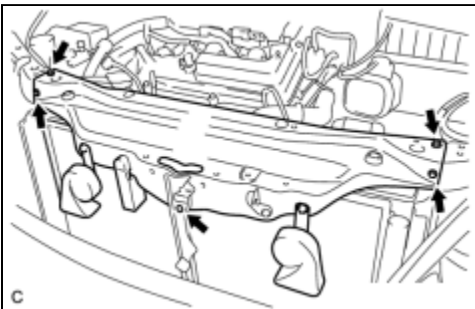

(f) Remove the 5 bolts and radiator support upper.

22. REMOVE FAN SHROUD

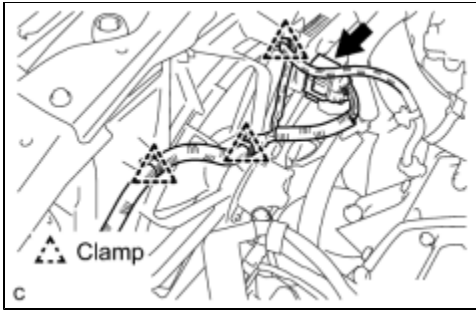

(a) Remove the 3 clamps and connector.

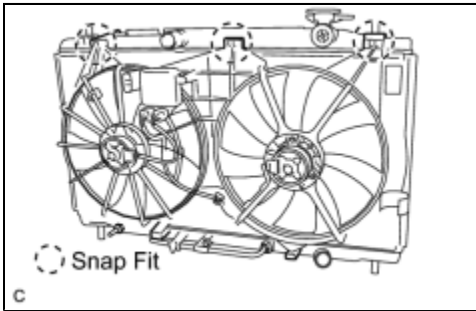

(b) Release the 3 snap fits and lift the fan assembly with motor from the radiator.

23. REMOVE RADIATOR ASSEMBLY

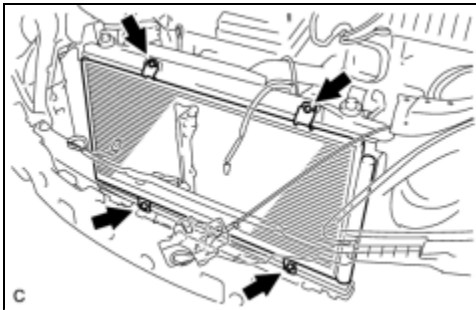

(a) Remove the 4 bolts and separate the condenser assembly from the radiator assembly.

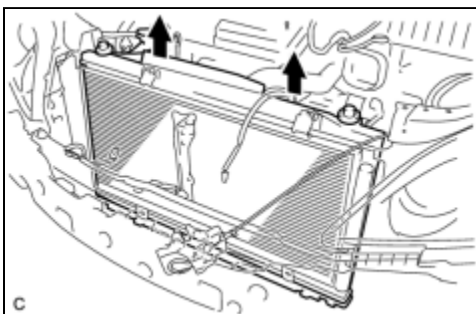

(b) Remove the radiator assembly from the body.

24. REMOVE RADIATOR SUPPORT CUSHION

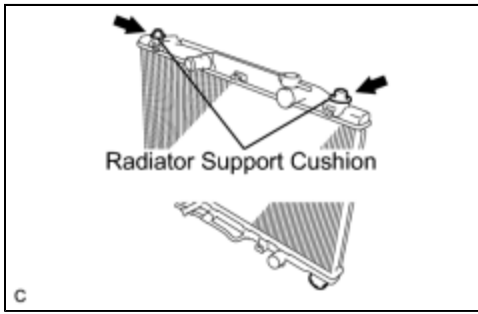

(a) Remove the 2 radiator support cushions from the radiator assembly.

25. REMOVE RADIATOR SUPPORT LOWER

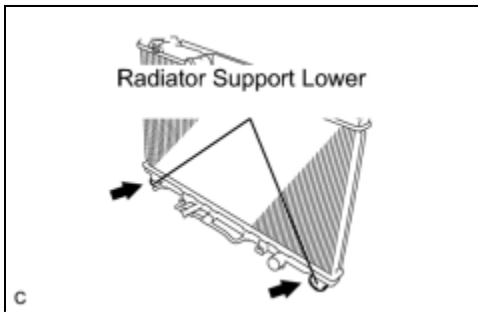

(a) Remove the 2 radiator support lowers from the radiator assembly.

