

Last Modified: 7-13-2007		1.6 K
Service Category: Engine/Hybrid System	Section: Cooling	
Model Year: 2008	Model: ES350	Doc ID: RM000001IQB00WX
Title: 2GR-FE COOLING: RADIATOR: COMPONENTS (2008 ES350)		

[COMPONENTS](#)

[ILLUSTRATION](#)

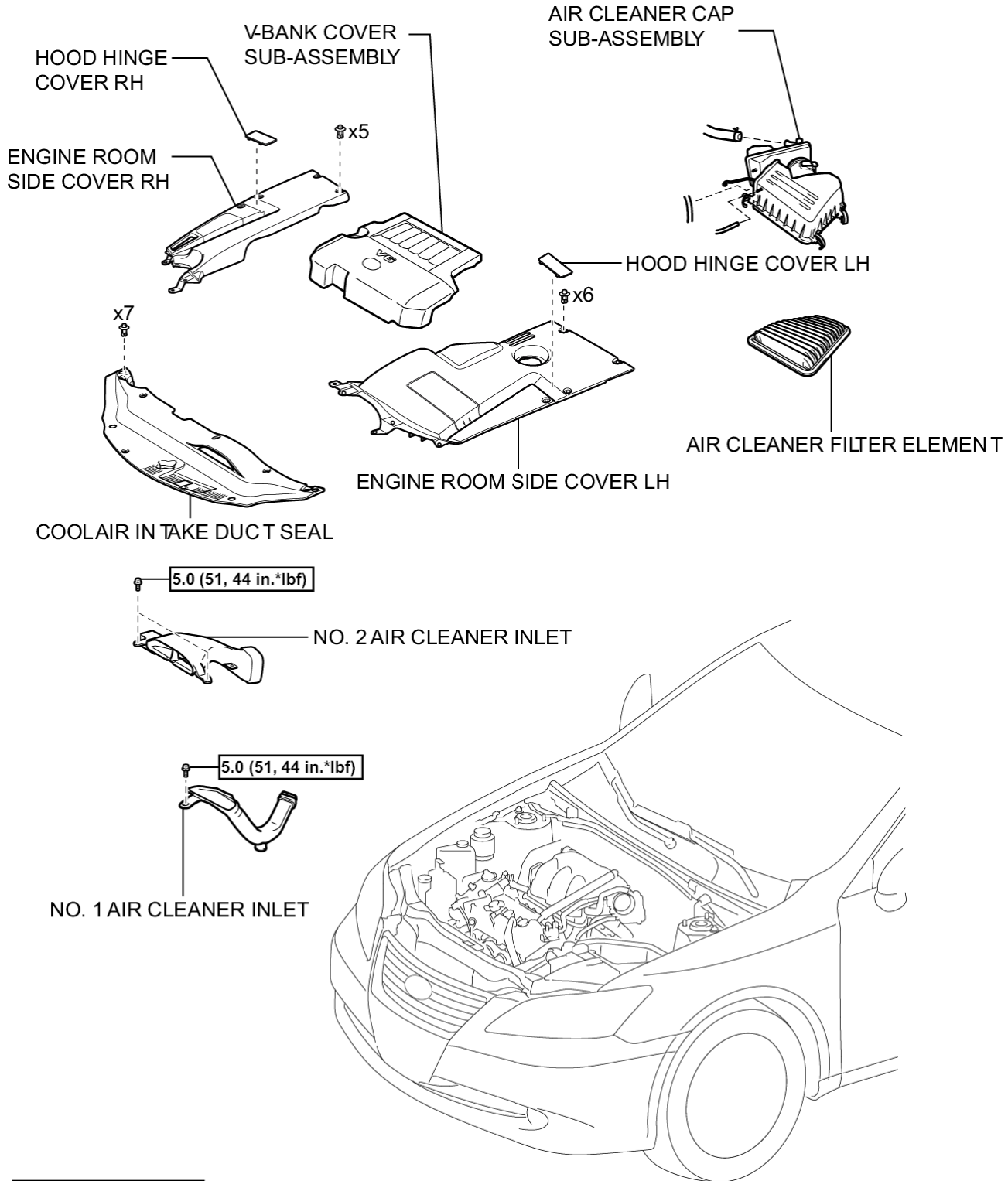

N*m (kgf*cm, ft.*lbf) : Specified torque

T

ILLUSTRATION

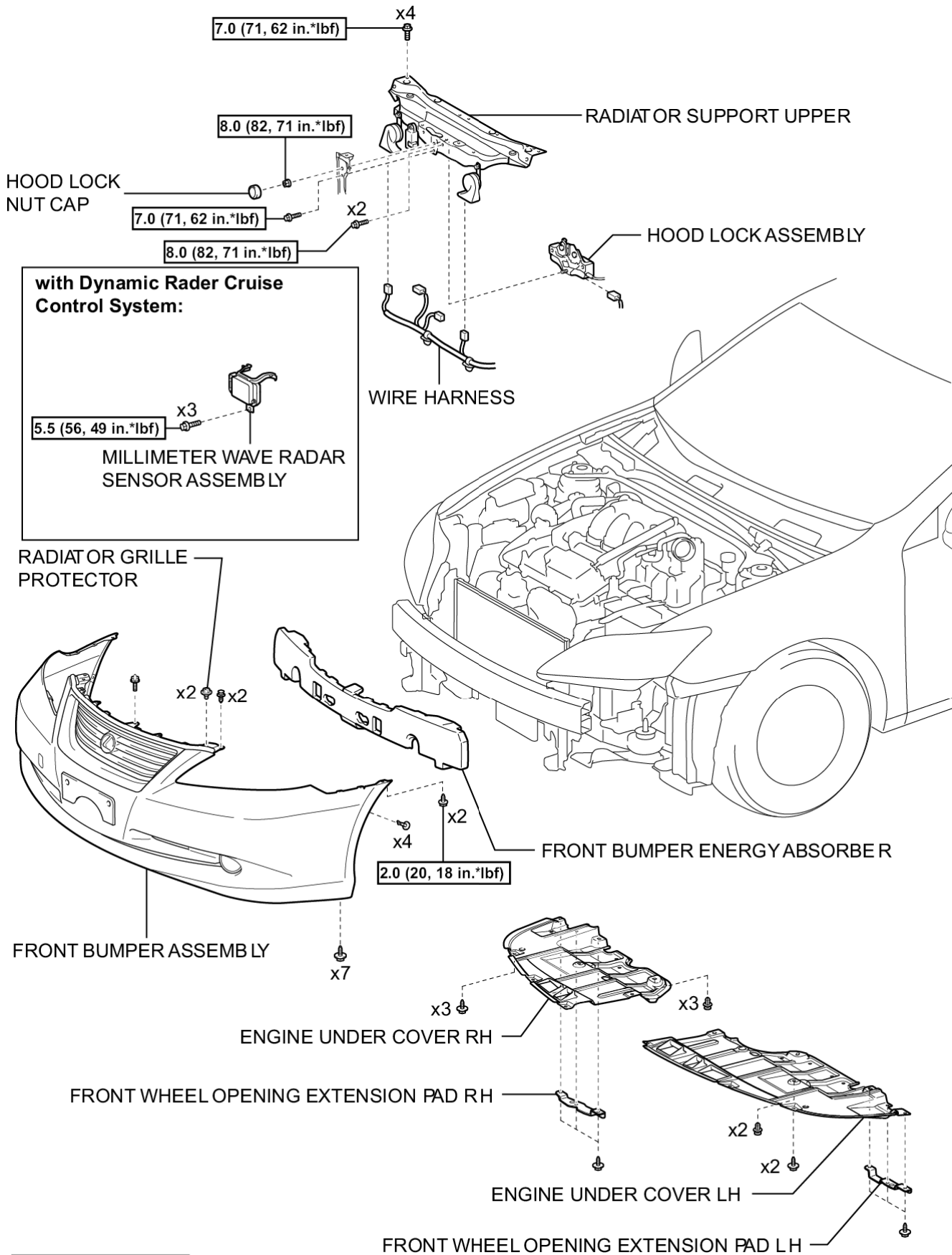

N*m (kgf*cm, ft.*lbf): Specified torque

T

ILLUSTRATION

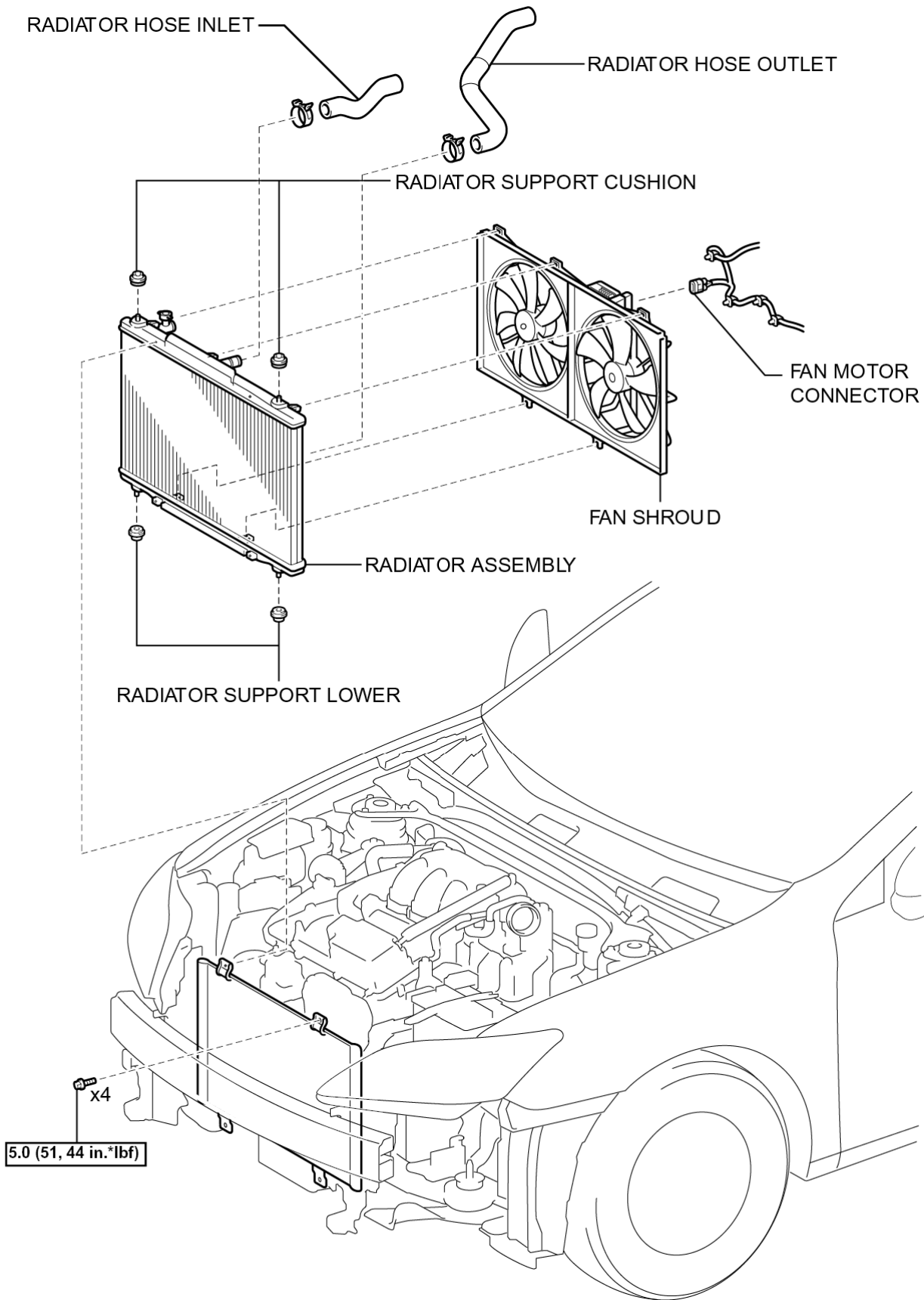

5.0 (51, 44 in.*lbf) : Specified torque

ILLUSTRATION

Without Hose:

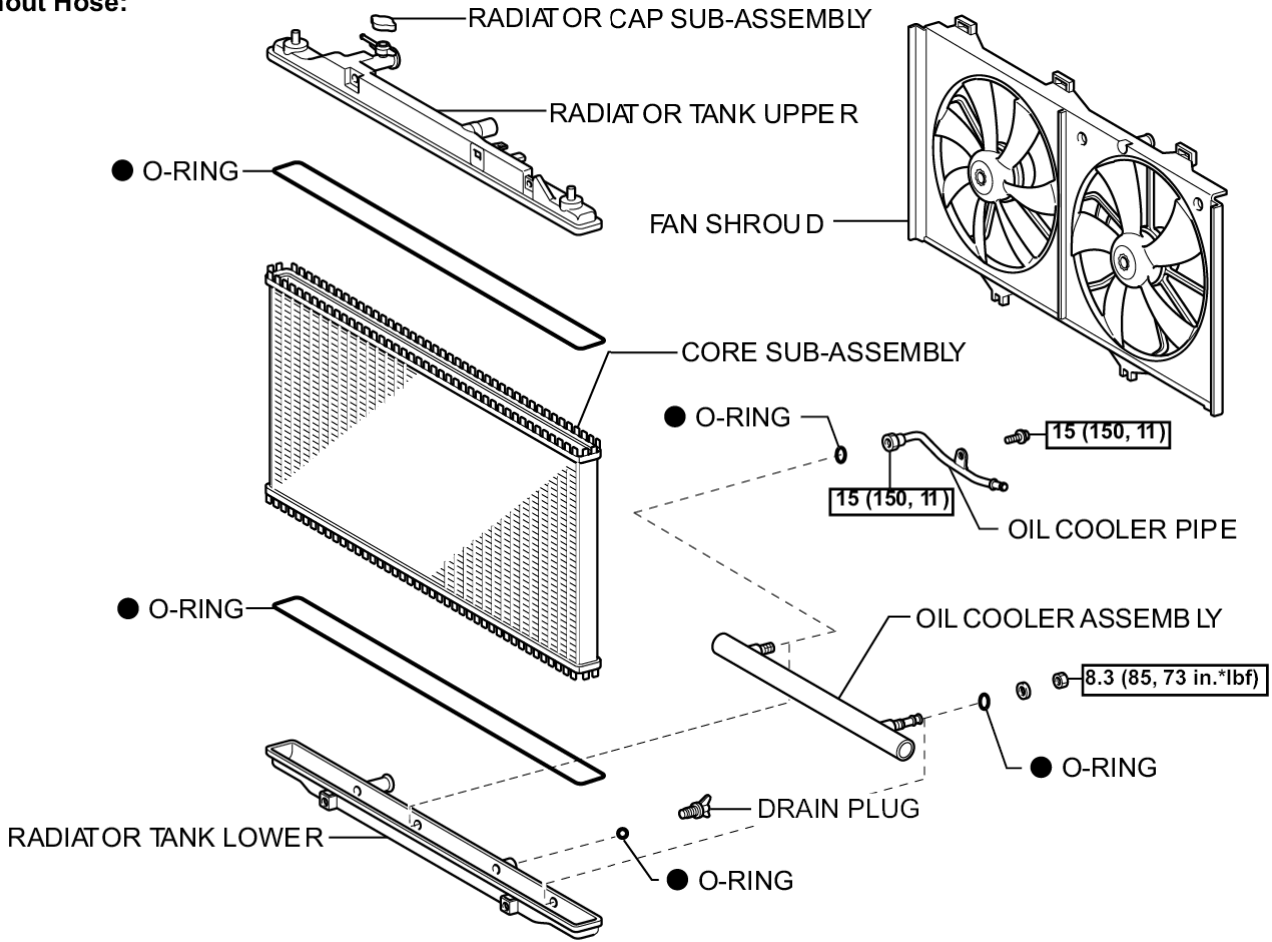

$\boxed{N*m (kgf*cm, ft.*lbf)}$: Specified torque ● Non-reusable part

T

ILLUSTRATION

With Hose:

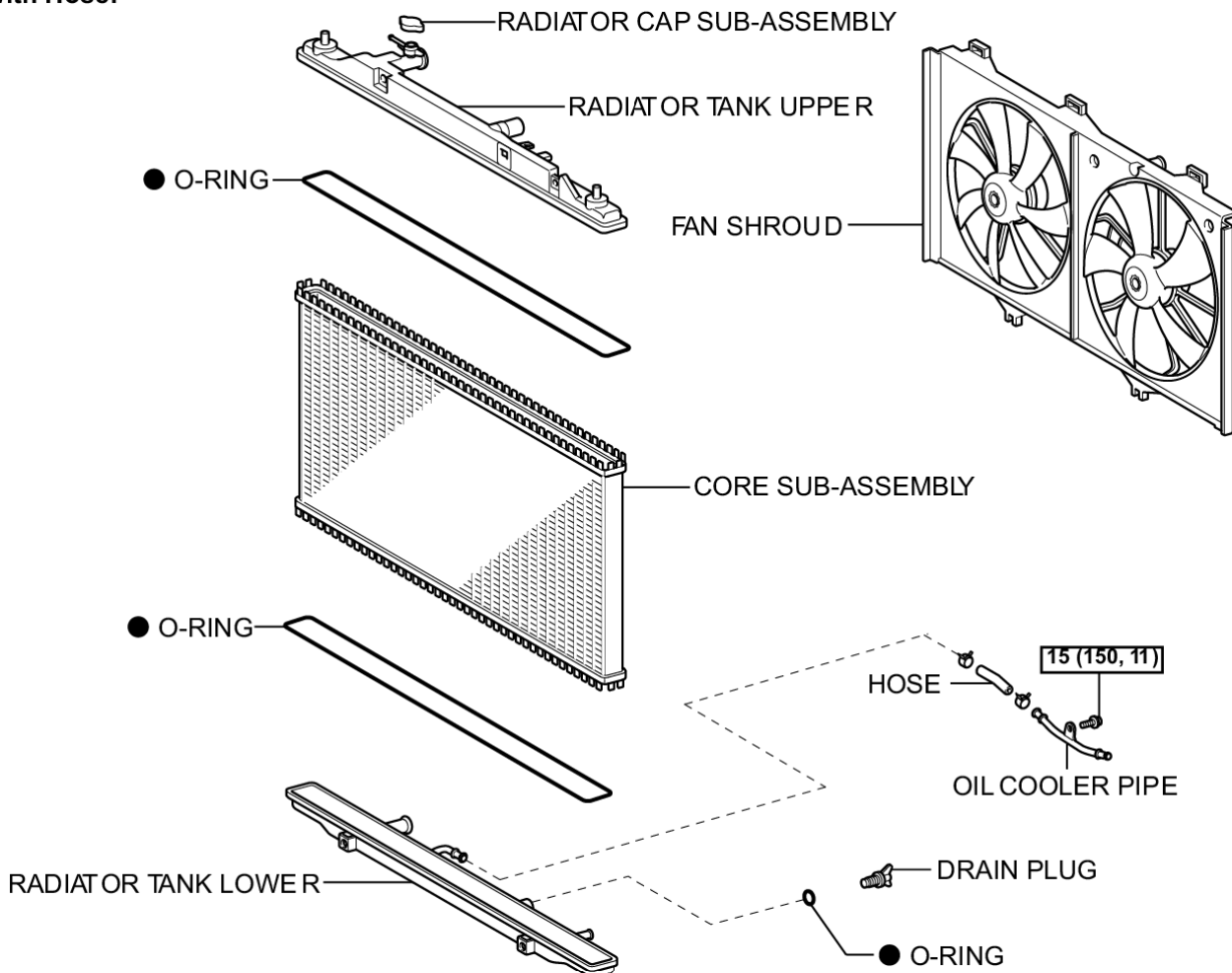

N*m (kgf*cm, ft.*lbf): Specified torque ● Non-reusable part

T

