

Last Modified: 7-13-2007		1.6 A
Service Category: Audio/Visual/Telematics		Section: Audio/Video
Model Year: 2008	Model: ES350	Doc ID: RM000001PZJ008X
Title: AUDIO / VISUAL: RADIO RECEIVER: REMOVAL (2008 ES350)		

## REMOVAL

1. REMOVE SHIFT LEVER KNOB SUB-ASSEMBLY

[INFO](#)

2. REMOVE UPPER CONSOLE PANEL ASSEMBLY WITH FRONT ASH RECEPTACLE

[INFO](#)

3. REMOVE INSTRUMENT PANEL FINISH PANEL END LH

[INFO](#)

4. REMOVE INSTRUMENT PANEL FINISH PANEL END RH

[INFO](#)

5. REMOVE NO. 2 INSTRUMENT PANEL REGISTER ASSEMBLY

[INFO](#)

6. REMOVE INTEGRATION CONTROL PANEL WITH RADIO RECEIVER ASSEMBLY (w/o Navigation System)

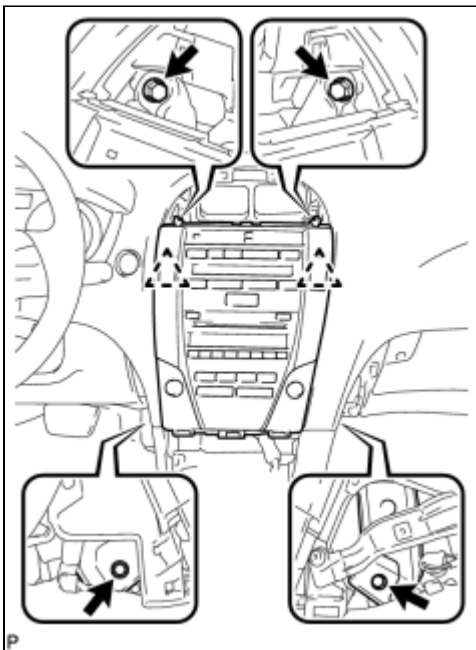

(a) Remove the 4 bolts.

(b) Pull the integration control panel with radio receiver assembly toward the rear of the vehicle and disengage the 2 clips.

(c) Disconnect each connector and remove the integration control panel with radio receiver assembly.

7. REMOVE NO. 1 RADIO BRACKET (w/o Navigation System)

(a) Remove the 4 bolts, screw, and No. 1 radio bracket.

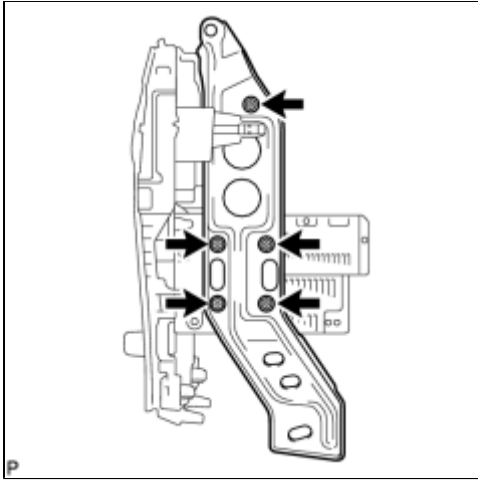

**8. REMOVE NO. 2 RADIO BRACKET (w/o Navigation System)**

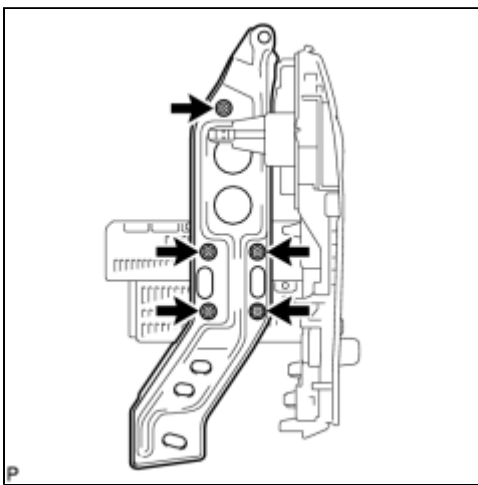

(a) Remove the 4 bolts, screw, and No. 2 radio bracket.

**9. REMOVE RADIO RECEIVER ASSEMBLY (w/o Navigation System)**

(a) Disengage the 2 claws and 6 clips.

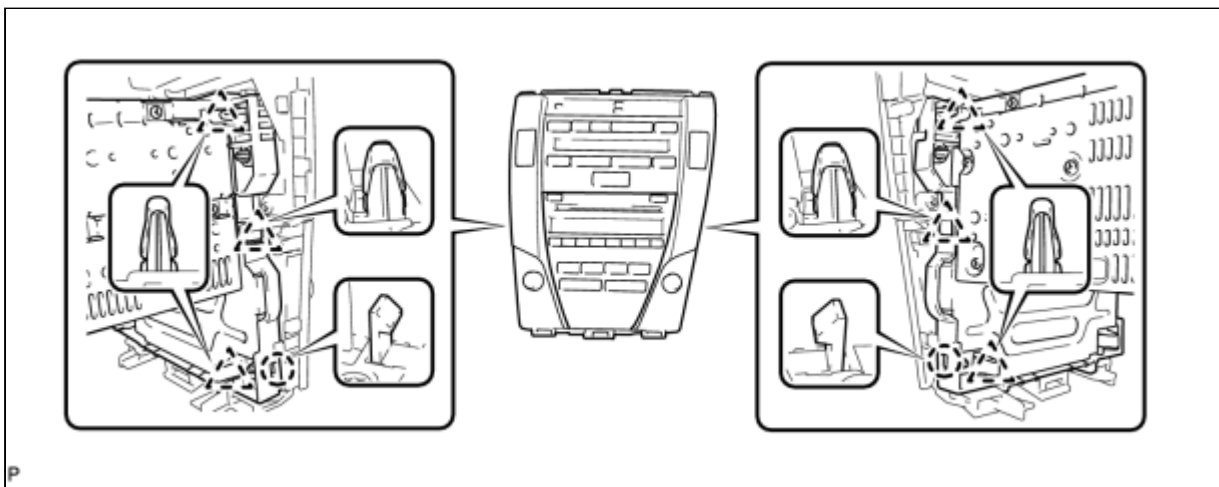

(b) Remove the radio receiver assembly.

**10. REMOVE MULTI-DISPLAY WITH RADIO RECEIVER ASSEMBLY (w/ Navigation System)**

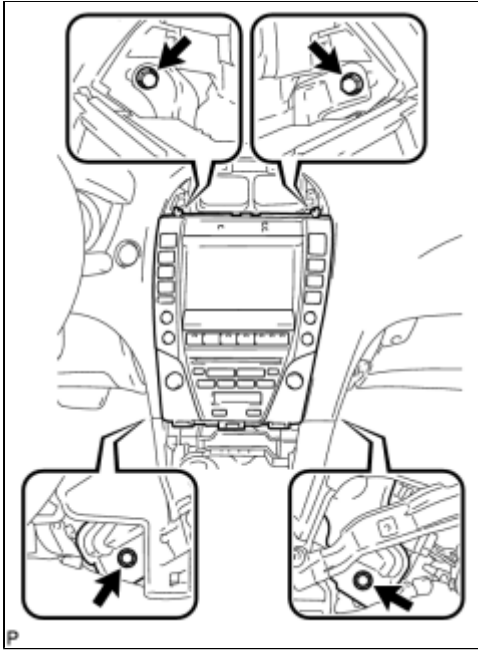

(a) Remove the 4 bolts.

(b) Pull the multi-display with radio receiver assembly toward the rear of the vehicle and disengage the 2 clips.

(c) Disconnect each connector and remove the multi-display with radio receiver assembly.

### 11. REMOVE NO. 1 RADIO BRACKET (w/ Navigation System)

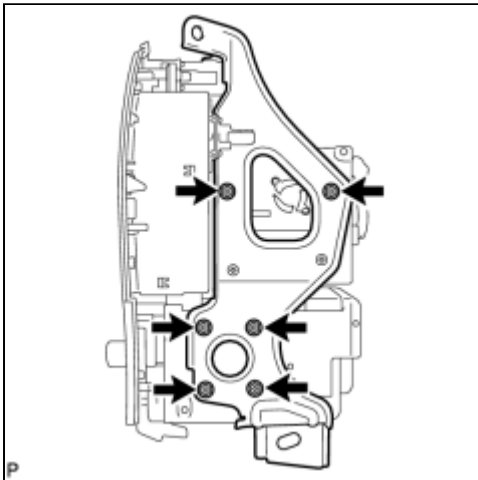

(a) Remove the 6 bolts and No. 1 radio bracket.

### 12. REMOVE NO. 2 RADIO BRACKET (w/ Navigation System)

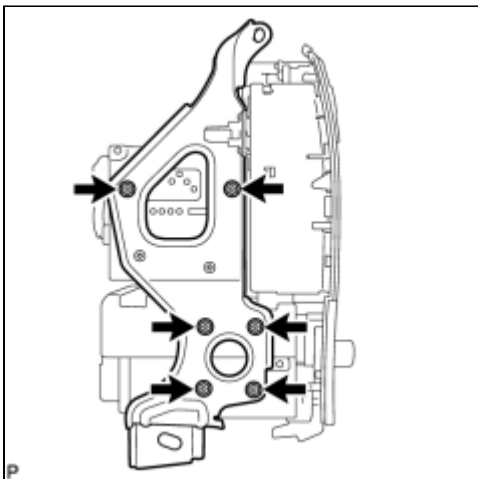

(a) Remove the 6 bolts and No. 2 radio bracket.

### 13. REMOVE RADIO RECEIVER ASSEMBLY (w/ Navigation System)

(a) Disengage the 2 claws and 4 clips.

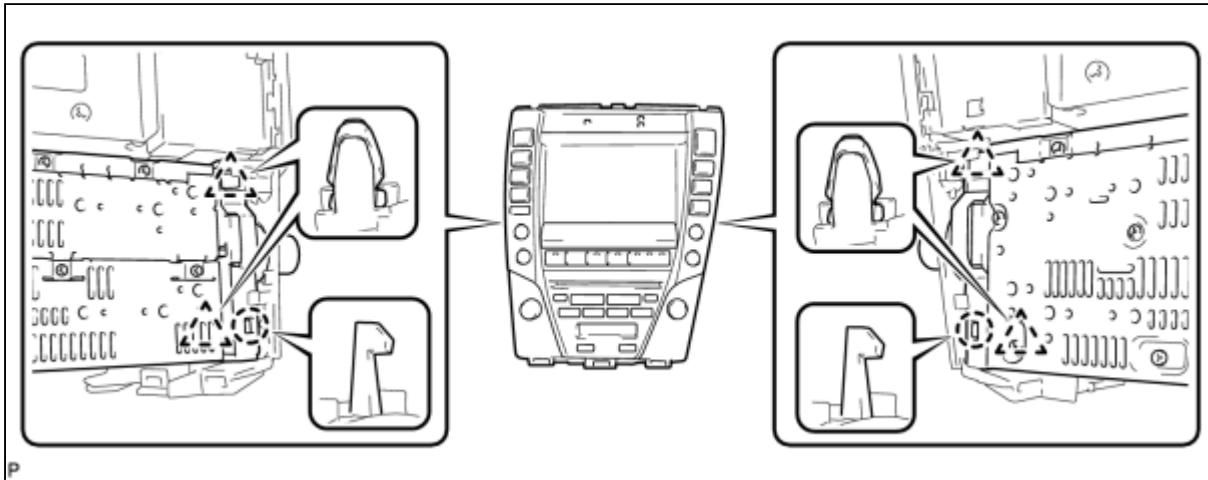

(b) Remove the radio receiver assembly.

