

Last Modified: 7-13-2007		1.7 C
Service Category: Vehicle Interior	Section: Heating/Air Conditioning	
Model Year: 2008	Model: ES350	Doc ID: RM000000STQ00XX
Title: AIR CONDITIONING: AIR CONDITIONING SYSTEM: B1424/24: Solar Sensor Circuit (Driver Side) (2008 ES350)		

DTC	B1424/24	Solar Sensor Circuit (Driver Side)
-----	----------	------------------------------------

DESCRIPTION

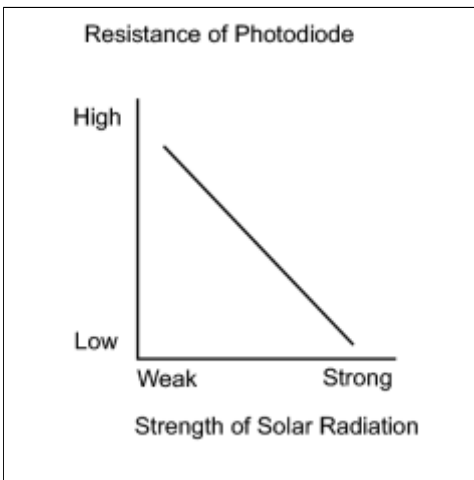

The solar sensor, which is installed on the upper side of the instrument panel, detects sunlight and controls the air conditioning in AUTO mode. The output voltage from the solar sensor varies according to the amount of sunlight. When the sunlight increases, the output voltage increases. As the sunlight decreases, the output voltage decreases. The A/C amplifier detects output voltage from the solar sensor.

DTC NO.	DTC DETECTION CONDITION	TROUBLE AREA
B1424/24	Open or short in driver side solar sensor circuit	<ul style="list-style-type: none"> • Solar sensor • Harness or connector between solar sensor and A/C amplifier • Harness or connector between solar sensor and main body ECU • A/C amplifier • Main body ECU

WIRING DIAGRAM

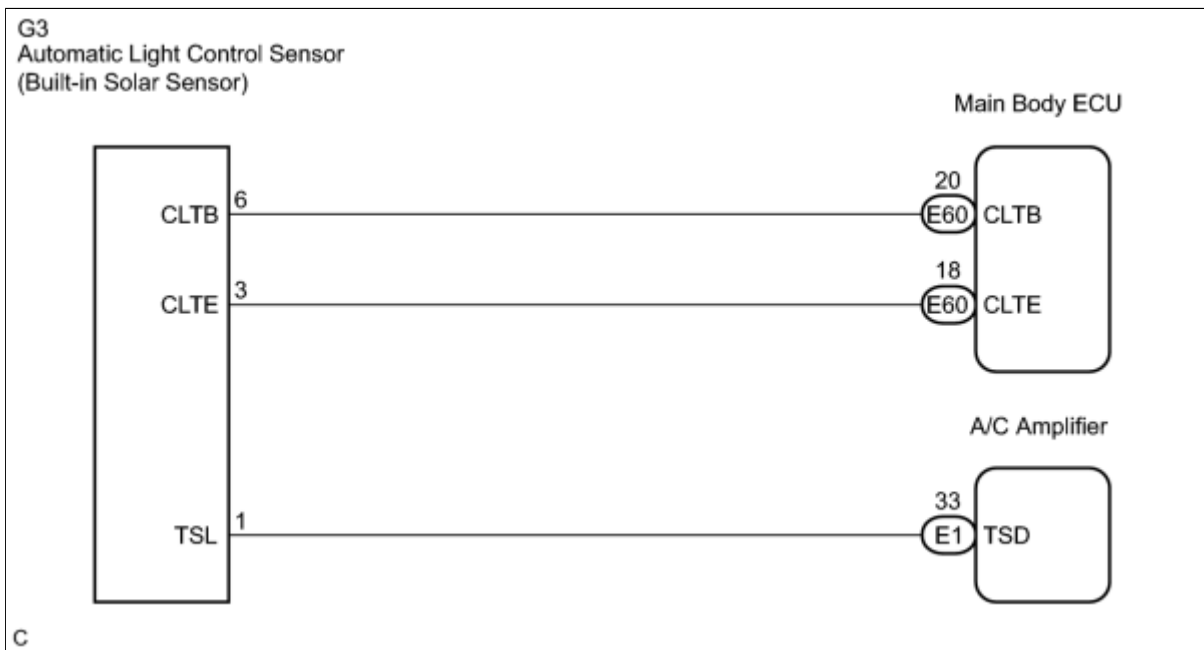

INSPECTION PROCEDURE

HINT:

- If DTC B1244 is output at the same time, troubleshoot DTC B1244 first INFO.
- If the check is performed in a dark place, DTC B1421/21 or B1424/24 (solar sensor circuit abnormal) may be output even though the system is normal.

PROCEDURE

1. READ VALUE OF TECHSTREAM

- Connect Techstream to the DLC3.
- Turn the engine switch on (IG) and turn Techstream on.
- Expose the sensing portion of the solar sensor to light.

HINT:

Use an incandescent light for inspection.

- Select the item below in the Data List, and read the display on Techstream.

Data List / Air Conditioner:

TESTER DISPLAY	MEASUREMENT ITEM/RANGE	NORMAL CONDITION	DIAGNOSTIC NOTE
Solar Sens-D (Solar Sensor (D side))	Driver side solar sensor / Min.: 0, Max.: 255	Driver side solar sensor value increases as brightness increases	-

OK:

The display is as specified in the normal condition column.

Result:

RESULT	PROCEED TO
NG	A
OK (When troubleshooting according to the PROBLEM SYMPTOMS TABLE)	B
OK (When troubleshooting according to the DTC)	C

B ▶ PROCEED TO NEXT CIRCUIT INSPECTION SHOWN IN PROBLEM SYMPTOMS TABLE

C ▶ REPLACE AIR CONDITIONING AMPLIFIER

A



2. CHECK HARNESS AND CONNECTOR (SOLAR SENSOR)

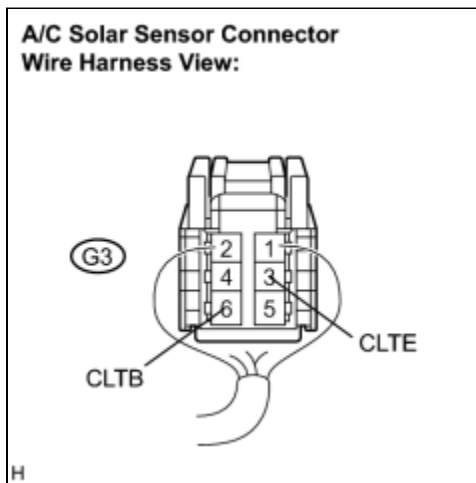

(a) Disconnect the solar sensor connector.

(b) Measure the voltage according to the value(s) in the table below.

Standard voltage:

TESTER CONNECTION	CONDITION	SPECIFIED CONDITION
G3-6 (CLTB) - G3-3 (CLTE)	Engine switch on (IG)	10 to 14 V
G3-6 (CLTB) - G3-3 (CLTE)	Engine switch off	Below 1 V

OK ▶ CHECK SOLAR SENSOR

NG



3. CHECK HARNESS AND CONNECTOR (SOLAR SENSOR - MAIN BODY ECU)

**Main Body ECU
Connector Front View:**

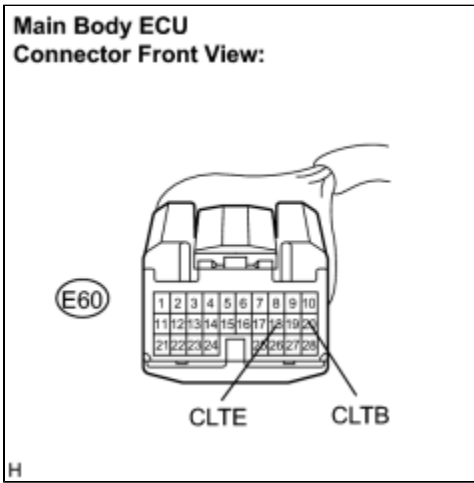

(a) Disconnect the main body ECU connector.

**A/C Solar Sensor Connector
Wire Harness View:**

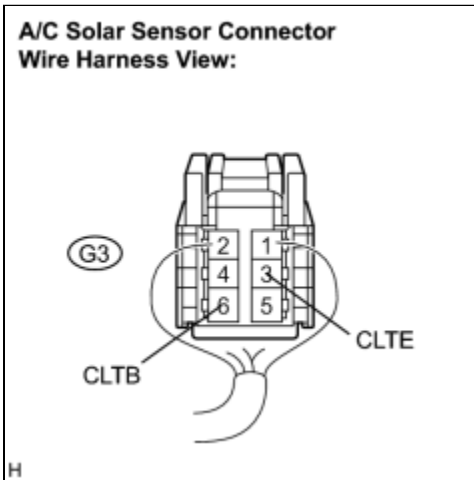

(b) Measure the resistance according to the value(s) in the table below.

Standard resistance:

TESTER CONNECTION	CONDITION	SPECIFIED CONDITION
E60-20 (CLTB) - G3-6 (CLTB)	Always	Below 1 Ω
E60-18 (CLTE) - G3-3 (CLTE)	Always	Below 1 Ω
E60-20 (CLTB) - Body ground	Always	10 k Ω or higher
E60-18 (CLTE) - Body ground	Always	10 k Ω or higher

NG ► REPAIR OR REPLACE HARNESS OR CONNECTOR

OK ► REPLACE MAIN BODY ECU

4. CHECK SOLAR SENSOR

Solar Sensor Connector Front View:

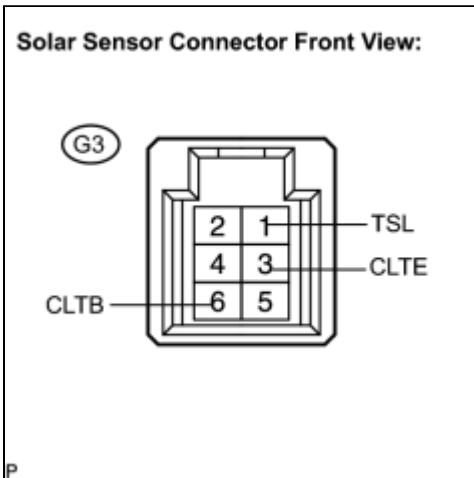

(a) Remove the solar sensor with its connector still connected.

(b) Connect the positive (+) lead from the battery to terminal 6 (CLTB), and the negative (-) lead to terminal 3

(CLTE) of the solar sensor.

(c) Measure the voltage according to the value(s) in the table below.

Standard voltage:

TESTER CONNECTION	CONDITION	SPECIFIED CONDITION
G3-1 (TSL) - G3-3 (CLTE)	Sensor is subjected to electric light	0.8 to 4.3 V
G3-1 (TSL) - G3-3 (CLTE)	Sensor is covered with a cloth	Below 0.8 V

NOTICE:

- The connection procedure for using a digital tester such as a TOYOTA electrical tester is shown above. When using an analog tester, connect the negative (-) lead to terminal 6, and the positive (+) lead to terminal 3 of the solar sensor.
- While using the battery during inspection, do not bring the positive and negative tester probes too close to each other as a short circuit may occur.

HINT:

- Use an incandescent light for inspection. Bring it within about 30 cm (11.8 in.) of the solar sensor.
- As the inspection light is moved away from the sensor, the voltage increases.

NG ▶ REPLACE SOLAR SENSOR

OK



5. CHECK HARNESS AND CONNECTOR (SOLAR SENSOR - A/C AMPLIFIER)

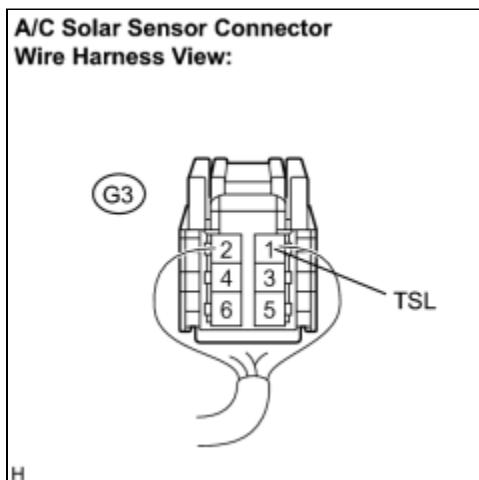

(a) Disconnect the solar sensor connector.

(b) Disconnect the A/C amplifier connector.

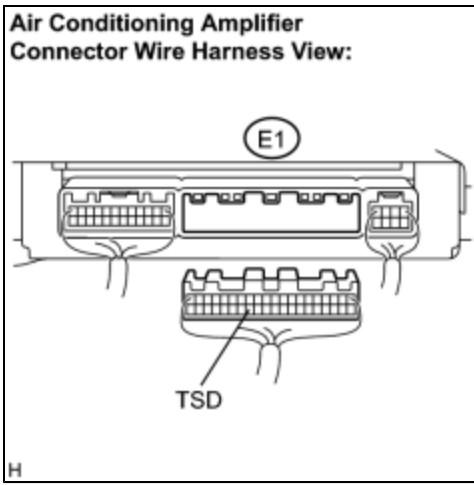

(c) Measure the resistance according to the value(s) in the table below.

Standard resistance:

TESTER CONNECTION	CONDITION	SPECIFIED CONDITION
E1-33 (TSD) - G3-1 (TSL)	Always	Below 1 Ω
E1-33 (TSD) - Body ground	Always	10 k Ω or higher

NG ▶ REPAIR OR REPLACE HARNESS OR CONNECTOR

OK ▶ REPLACE AIR CONDITIONING AMPLIFIER

