

<b>Last Modified:</b> 7-13-2007		1.7 C
<b>Service Category:</b> Vehicle Interior	<b>Section:</b> Heating/Air Conditioning	
<b>Model Year:</b> 2008	<b>Model:</b> ES350	<b>Doc ID:</b> RM000000STR00SX
<b>Title:</b> AIR CONDITIONING: AIR CONDITIONING SYSTEM: B1441/41: Air Mix Damper Control Servo Motor Circuit (Passenger Side) (2008 ES350)		

<b>DTC</b>	<b>B1441/41</b>	<b>Air Mix Damper Control Servo Motor Circuit (Passenger Side)</b>
------------	-----------------	--

## DESCRIPTION

The air mix damper servo sends pulse signals to inform the air conditioning amplifier of the damper position. The air conditioning amplifier activates the motor (normal, reverse) based on the signals to move the air mix damper (passenger seat) to any position, which adjusts the amount of air passing the heater core after passing the evaporator to control the blowing temperature.

### HINT:

**Confirm that no mechanical problem is present because this diagnostic code can be output when either a damper link or damper is mechanically locked.**

DTC NO.	DTC DETECTION CONDITION	TROUBLE AREA
B1441/41	Air mix damper position sensor value does not change even if air conditioning amplifier operates air mix control servo motor	<ul style="list-style-type: none"> <li>● Air mix control servo motor</li> <li>● Air conditioning harness</li> <li>● A/C amplifier</li> </ul>

## WIRING DIAGRAM

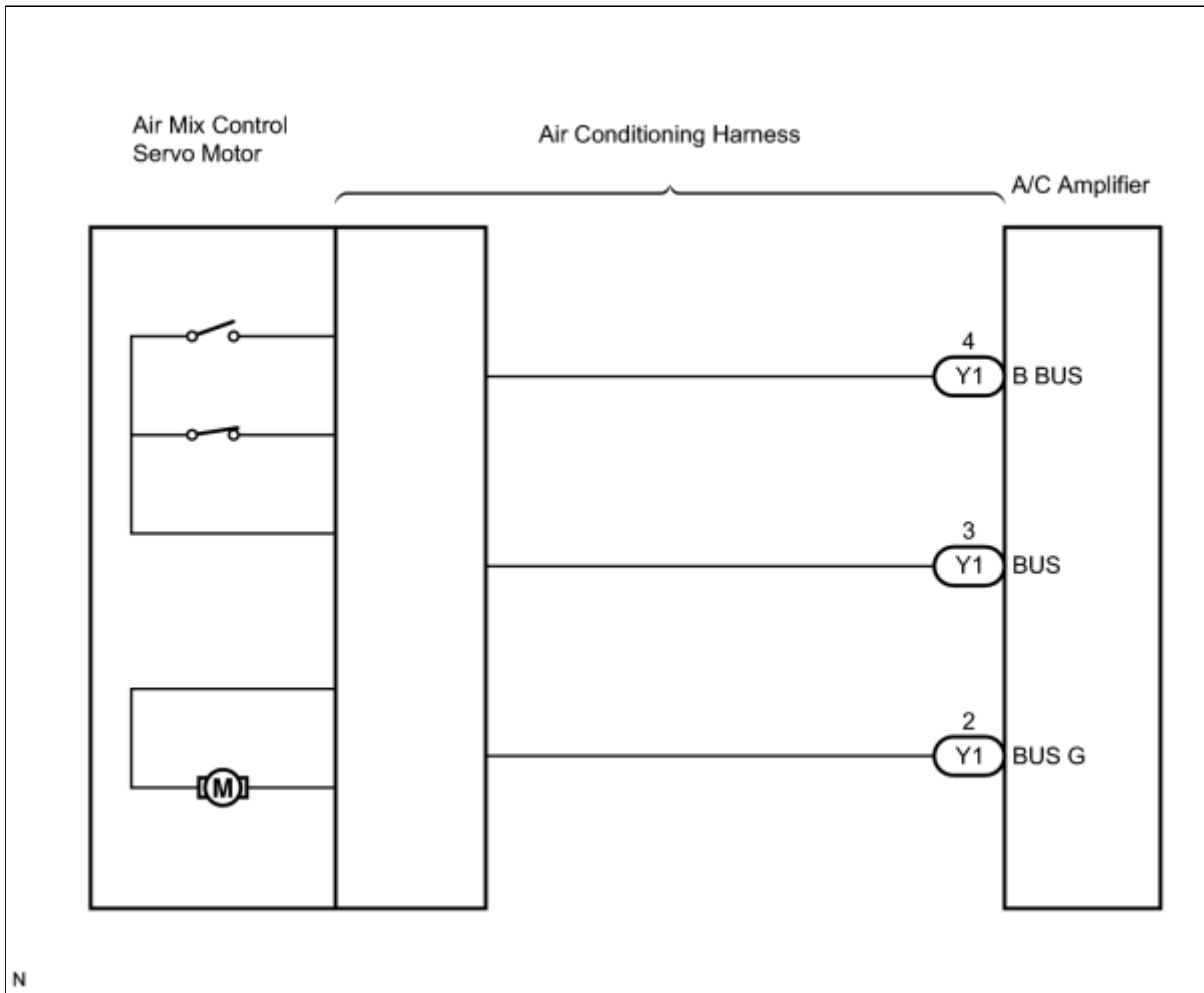

## INSPECTION PROCEDURE

### PROCEDURE

#### 1. READ VALUE OF TECHSTREAM

- (a) Connect Techstream to the DLC3.
- (b) Turn the engine switch on (IG) and turn Techstream on.
- (c) Operate the front passenger side temperature adjustment switch.
- (d) Select the item below in the Data List, and read the display on Techstream.

#### Data List / Air Conditioner:

TESTER DISPLAY	MEASUREMENT ITEM/RANGE	NORMAL CONDITION	DIAGNOSTIC NOTE
Air Mix Pulse-P (Air Mix Servo Targ Pulse (P))	Passenger side air mix servo motor target pulse / Min.: 0, Max.: 255	MAX. COLD: 105 (pulse) MAX. HOT: 7 (pulse)	-

OK:

The display is as specified in the normal condition column.

Result:

RESULT	PROCEED TO
NG	A
OK (When troubleshooting according to the PROBLEM SYMPTOMS TABLE)	B
OK (When troubleshooting according to the DTC)	C

**B** ▶ PROCEED TO NEXT CIRCUIT INSPECTION SHOWN IN PROBLEM SYMPTOMS TABLE

**C** ▶ REPLACE AIR CONDITIONING AMPLIFIER

**A**  
▼

<b>2.</b>	<b>REPLACE AIR MIX CONTROL SERVO MOTOR</b>
-----------	--

(a) Replace the air mix control servo motor.

**HINT:**

Since the servo motor cannot be inspected while it is removed from the vehicle, replace the servo motor with a normal one and check that the condition returns to normal.

(b) Check for DTCs.

Result:

RESULT	PROCEED TO
DTC B1441/41 is output	A
DTC B1441/41 is not output	B

**B** ▶ END

**A** ▶ REPLACE AIR CONDITIONING HARNESS

