

Last Modified: 7-13-2007		1.6 A
Service Category: Vehicle Exterior	Section: Exterior Panels/Trim	
Model Year: 2008	Model: ES350	Doc ID: RM000002DEC002X
Title: EXTERIOR: FRONT BUMPER: DISASSEMBLY (2008 ES350)		

DISASSEMBLY

1. REMOVE NO. 1 ULTRASONIC SENSOR (w/ Intuitive Parking Assist System) [INFO](#)

2. REMOVE NO. 1 ULTRASONIC SENSOR RETAINER (w/ Intuitive Parking Assist System) [INFO](#)

3. REMOVE FRONT BUMPER HOLE COVER

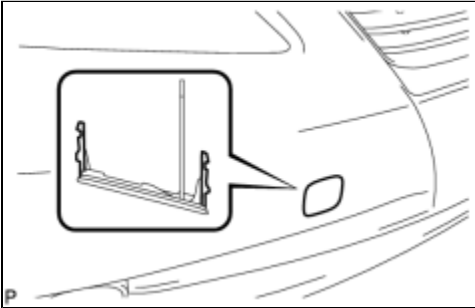

(a) Disengage the 2 claws and remove the front bumper hole cover.

4. REMOVE FRONT BUMPER EXTENSION MOUNTING BRACKET

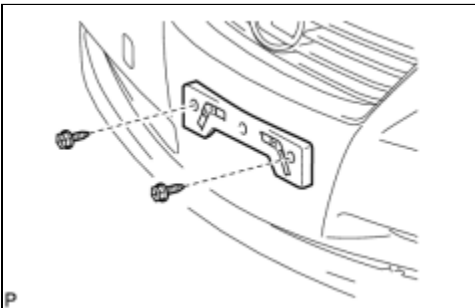

(a) Remove the 2 screws and front bumper extension mounting bracket.

5. REMOVE RADIATOR GRILLE SEAL

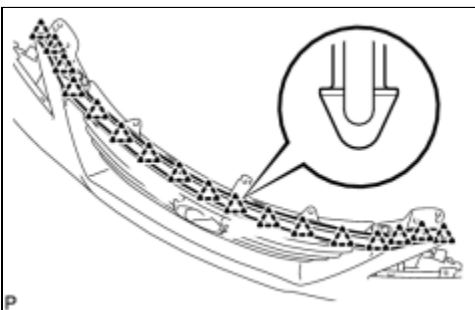

(a) Disengage the 17 clips and remove the radiator grille seal.

6. REMOVE RADIATOR GRILLE

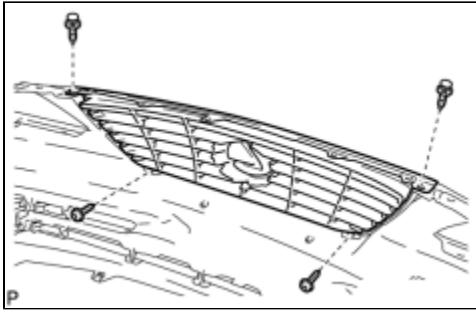

(a) Remove the 2 screws and 2 clips.

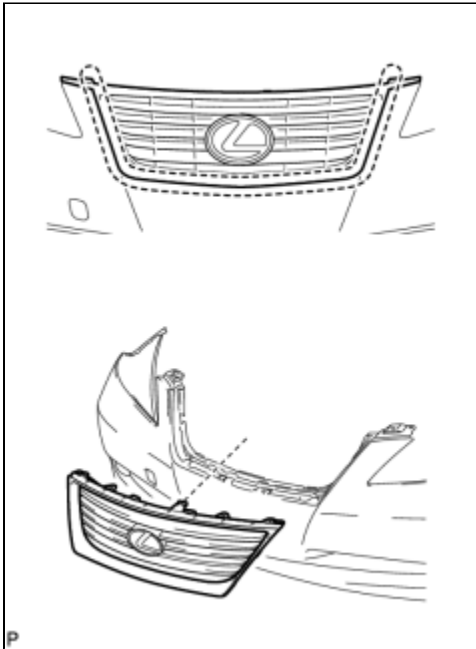

(b) Disengage each claw and remove the radiator grille and radiator grille moulding.

7. REMOVE RADIATOR GRILLE MOULDING

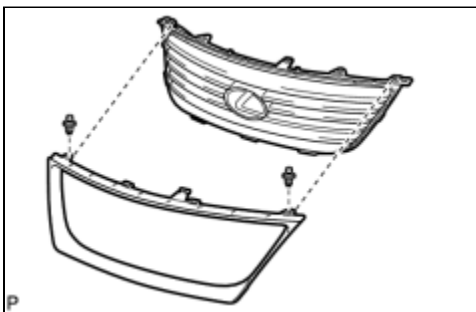

(a) Remove the 2 clips.

(b) Disengage each claw and remove the radiator grille moulding.

8. REMOVE RADIATOR GRILLE EMBLEM (w/o Dynamic Radar Cruise Control System)

HINT:

When removing the emblem, heat the radiator grille and emblem using a heat light.

Heating temperature:

ITEM	TEMPERATURE
Radiator Grille	40 to 60°C (104 to 140°F)
Emblem	20 to 30°C (68 to 86°F)

NOTICE:

Do not heat the radiator grille and emblem excessively.

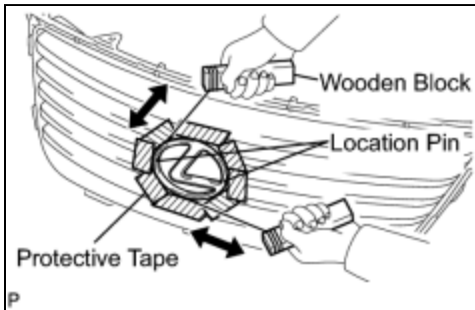

(a) Put protective tape around the radiator grille emblem.

(b) Insert a piano wire between the radiator grille and radiator grille emblem.

(c) Tie objects that can serve as handles (for example, wooden blocks) to both wire ends.

(d) Pull the piano wire and scrape off the double-sided tape that holds the moulding to the radiator grille.

NOTICE:

- If reusing the radiator grille emblem, take care not to damage the radiator grille emblem.
- Be careful not to damage the radiator grille.

(e) Remove the radiator grille emblem.

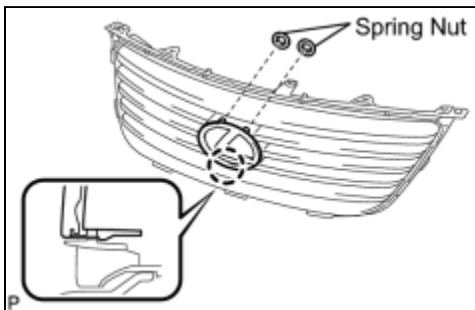
9. REMOVE RADIATOR GRILLE EMBLEM (w/ Dynamic Radar Cruise Control System)

(a) Remove the 2 spring nuts.

(b) Disengage the claw and remove the radiator grille emblem.

10. REMOVE FOG LIGHT ASSEMBLY LH

#1FC

11. REMOVE FOG LIGHT ASSEMBLY RH**12. REMOVE FOG LIGHT BRACKET LH**

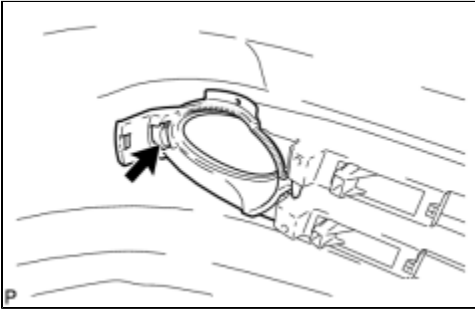

(a) Disengage the claw and remove the fog light bracket LH.

13. REMOVE FOG LIGHT BRACKET RH

14. REMOVE RADIATOR GRILLE GARNISH

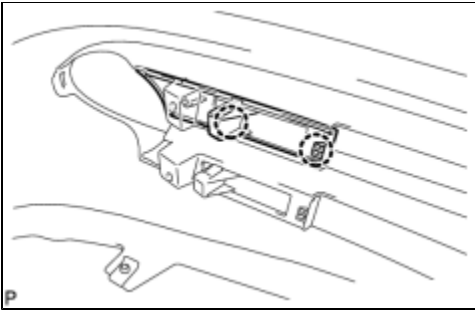

(a) Disengage the 2 claws and radiator grille garnish.

HINT:

Use the same procedures for the RH side and LH side.

15. REMOVE NO. 2 RADIATOR GRILLE GARNISH

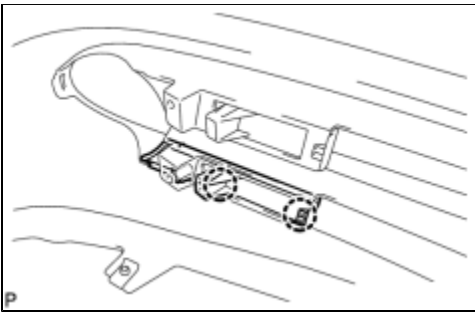

(a) Disengage the 2 claws and No. 2 radiator grille garnish.

HINT:

Use the same procedures for the RH side and LH side.

16. REMOVE NO. 3 RADIATOR GRILLE GARNISH

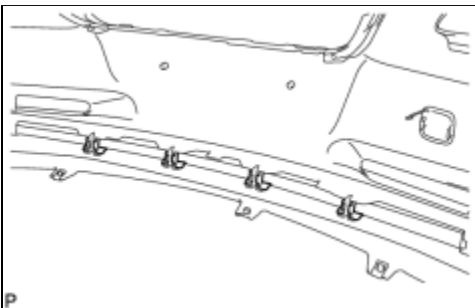

(a) Remove the 4 No. 3 radiator grille garnishes.

17. REMOVE FRONT BUMPER ENERGY ABSORBER

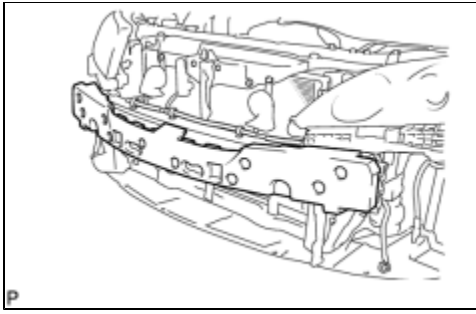

(a) Remove the front bumper energy absorber from the front bumper reinforcement.

18. REMOVE FRONT BUMPER REINFORCEMENT

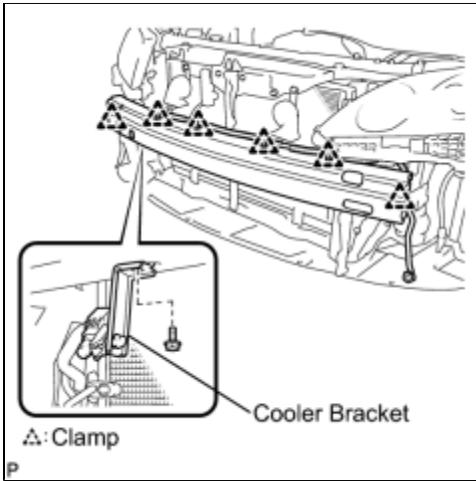

(a) Disengage each clamp.

(b) Remove the bolt and separate the cooler bracket.

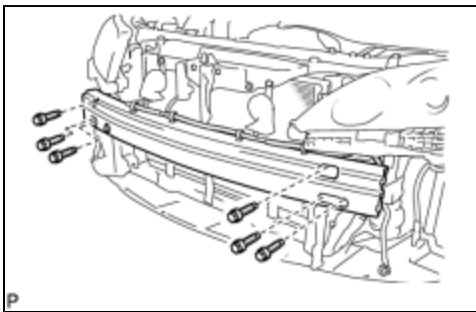

(c) Remove the 6 bolts and front bumper reinforcement.

19. REMOVE FRONT BUMPER STAY LH

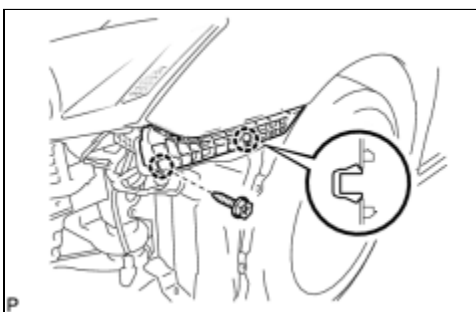

(a) Remove the screw.

(b) Disengage the 2 claws and remove the front bumper stay LH.

20. REMOVE FRONT BUMPER STAY RH

