

Part Number: PT29A-33085-XX
PT29A-33095-XX
PT29A-33100-XX
PT29A-00120-XX

PT29A-33130-XX
PT29A-48111-XX

NOTE: Part number of this accessory may not be the same as the part number shown

Kit Contents

Item #	Quantity Reqd.	Description
1	1	Molding, LH Front Door
2	1	Molding, LH Rear Door
3	1	Molding, RH Front Door
4	1	Molding, RH Rear Door

Hardware Bag Contents

Item #	Quantity Reqd.	Description
1		
2		

Additional Items Required For Installation

Item #	Quantity Reqd.	Description
1		
2		

Conflicts

None

Recommended Tools

Personal & Vehicle Protection	Notes
Safety Glasses	
Vehicle Protection	Seat & Floor Covers
Special Tools	Notes
Roller	Hard Rubber Hand Roller, 1" to 3" wide.
Non intrusive Infrared Temp Probe/Gun	
Installation Tools	Notes
Flexible Scale or Tape Measure	
Masking Tape	2" wide
Clean Lint-free Cloths	
Straight Edge (Plastic)	
Heat Gun (if required to warm surfaces)	
Heat Source	
Special Chemicals	Notes
Cleaner	3M™ Prep Solvent-70

General Applicability

Body Side Molding can be installed on all ES 350/300h Models
--

Recommended Sequence of Application

Item #	Accessory
1	Body Side Molding
2	Door Edge Guards

*Mandatory

Vehicle Service Parts (may be required for reassembly)

Item #	Quantity Reqd.	Description

Legend

 **STOP:** Damage to the vehicle may occur. Do not proceed until process has been complied with.

 **OPERATOR SAFETY:** Use caution to avoid risk of injury.

 **CAUTION:** A process that must be carefully observed in order to reduce the risk of damage to the accessory/vehicle and to ensure a quality installation.

 **TOOLS & EQUIPMENT:** Used in Figures calls out the specific tools and equipment recommended for this process.

 **REVISION MARK:** This mark highlights a change in installation with respect to previous issue.

 **SAFETY TORQUE:** This mark indicates that torque is related to safety.

Care must be taken when installing this accessory to ensure damage does not occur to the vehicle. The installation of this accessory should follow approved guidelines to ensure a quality installation.

These guidelines can be found in the "Accessory Installation Practices" document.





This document covers such items as:-

- Vehicle Protection (use of covers and blankets, cleaning chemicals, etc.).
- Safety (eye protection, rechecking torque procedure, etc.).
- Vehicle Disassembly/Reassembly (panel removal, part storage, etc.).
- Electrical Component Disassembly/Reassembly (battery disconnection, connector removal, etc.).

Please see your Lexus dealer for a copy of this document.



1. Vehicle Preparation

-  (a) Before working on the vehicle, protect the seats and carpets with covers.
-  (b) The work area, body side moldings, and vehicle door surface temperatures must be at least 60°F.
- (c) Saturate a clean lint-free cloth with 3M™ Prep Solvent-70 and clean the areas of each door as shown in Fig. (1-1).
 -  (1) When cleaning with 3M™ Prep Solvent-70, follow the manufacturer's directions. Do not allow cleaner to air dry.
 - (d) Wipe the cleaned surfaces with a clean, dry, lint-free cloth.
-  **NOTE:** Once cleaned do not contaminate this surface by touching it with your bare hands.

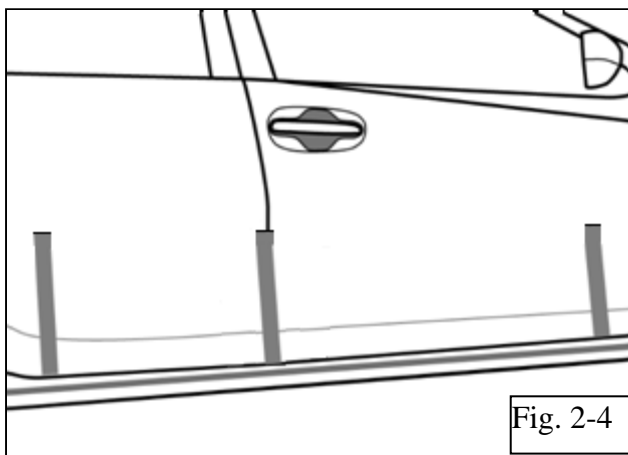
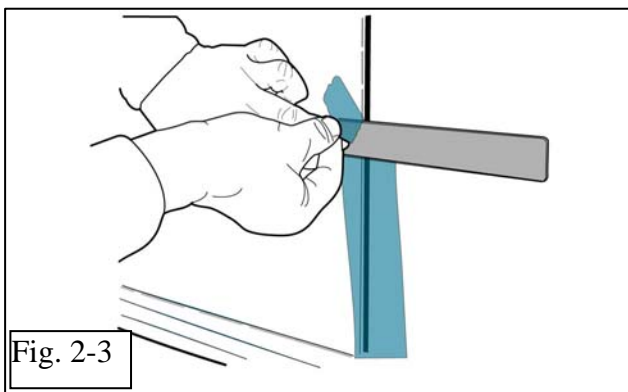
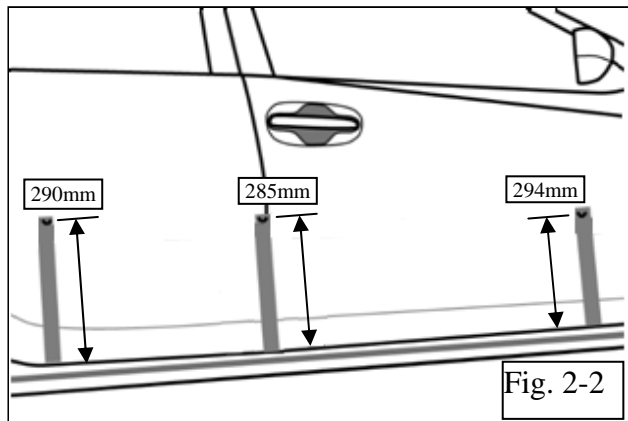
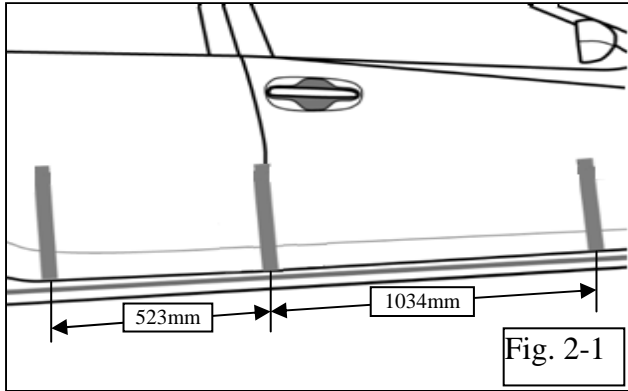

2. Alignment Tape Application

- (a) Measure 1034mm forward from the bottom rear edge of the front door and place a vertical piece of tape on the front door approximately 350mm long. Place a vertical piece of tape over the door gap between the front and rear doors approximately 350mm long. Measure 523mm rearward from the front bottom edge of the rear door and place a vertical piece of tape on the rear door approximately 350mm long. See (Fig. 2-1).
- (b) Measure up from the bottom of the door edges and place a horizontal mark on the three vertical pieces of tape as shown (Fig. 2-2).
- (c) Using a straight edge, tear the vertical tape along a horizontal line at the upper mark as shown in Fig. 2-3 & 2-4
- (d) Repeat Steps 2. (a) to 2. (c) for the other side of vehicle.

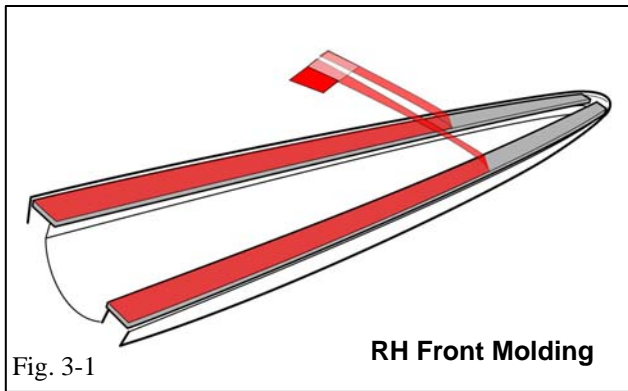

3. Body Side Molding Installation.

- ⚠ (a) On the inside of each of the four moldings is identified as to their correct position on the vehicle. Start with the RH front door molding. While carefully holding the molding by its edges, pull the plastic tape at the end of the part to remove the orange release liner from the black acrylic foam tape strips. (Fig. 3-1)

STOP NOTE: Once the release liner is removed from the molding, the surface of the foam tape must not be touched!

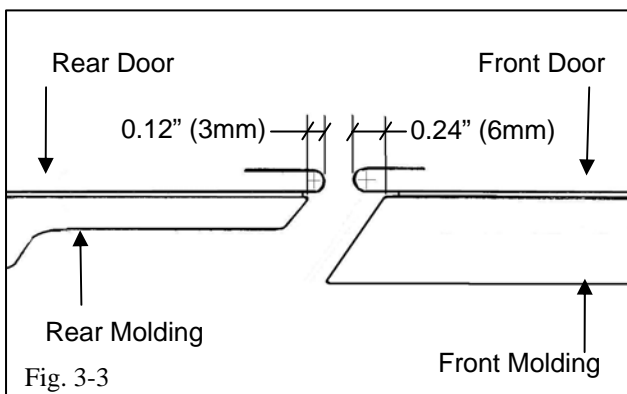
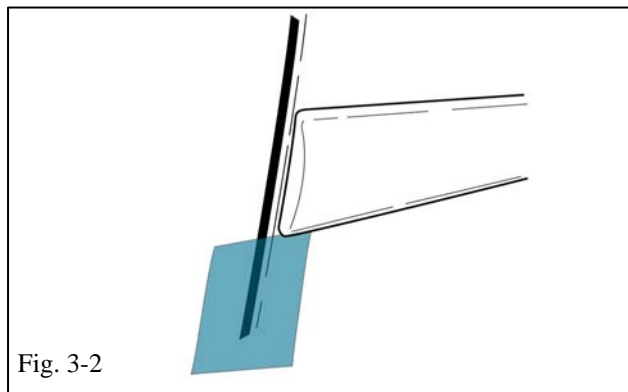

- ⚠ (b) Hold the molding about 1/2" from the surface of the front door, align the rear edge of the molding **6 mm** from the rear edge of the front door as shown in Fig. 3-2 & Fig. 3-3. The rear bottom edge of the molding aligns vertically with the top edge of the vertical tape strip. The front portion of the molding aligns with the top edge of the tape strip at the front of the door. Once the molding is properly aligned, press it to the door surface starting at the rear and working toward the front with a rolling motion. Do not allow both ends to contact and stick to the door before the center contacts.

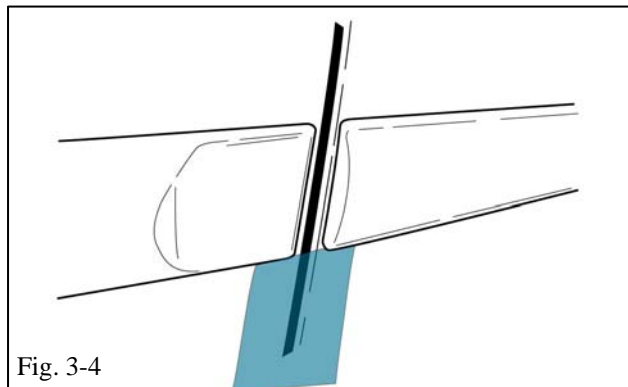

- (c) Repeat steps 3-a and 3-b for the RH rear door molding placing the front edge of the molding **3 mm** from the door edge as shown in Fig. 3-3 and Fig. 3-4.

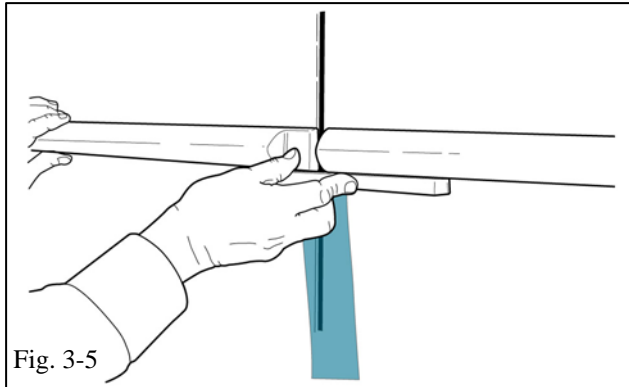

NOTE: A good way to ensure that where the rear and front molding meet between the doors align vertically is to hold a plastic straight edge against the bottom of the front molding and use it as a guide for the rear molding as shown in Fig. 3-5. Tolerance for alignment in the vertical direction of the front and rear molding in relation to each other is 0.0mm +/-1.0mm.

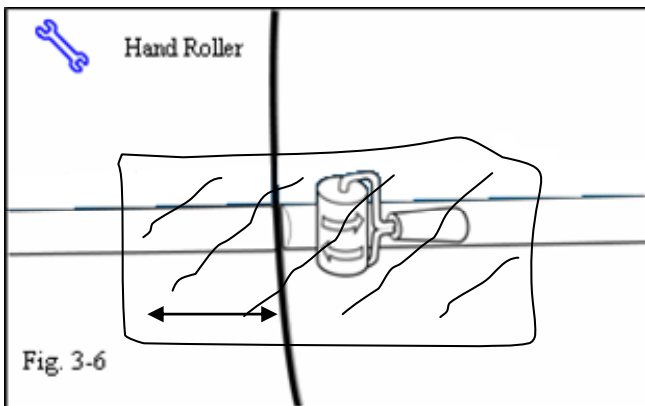

- (d)  Using the hand roller and clean rag, roll around the perimeter of the parts with firm pressure to ensure complete adhesion of the tape to the door surface. Use the rag to protect the sheet metal and the molding. (Fig. 3-6)
- (e) Remove and discard all the tape strips.
- (f) Repeat the entire installation procedure for the other side of the vehicle.

Checklist - these points **MUST** be checked to ensure a quality installation.

Check:

Look For:

Accessory Function Checks

Check visual alignment

The moldings should be visually straight.

The front edge of the rear moldings should be 3 mm away from the front edge of the rear door.

The inside rear edge of the front moldings should be 6mm away from the rear edge of the front doors.

Check for proper tape adhesion.

|| Confirm 100% tape adhesion completely around the part between the Body Side Molding and door sheet metal.

Vehicle Function Checks

None Required

Vehicle Appearance Checks

After accessory installation and removal of protective cover(s), perform a visual inspection.

Ensure no damage (including scuffs and scratches) was caused during the installation process. (For PPO installation, refer to Accessory Quality Shipping Standard.)