

INSTALLATION

1. CLEAN BODY MOUNTING SURFACE

- (a) Using a heat light, heat the body mounting surface to 40 – 60 °C (104 – 140 °F).

NOTICE:

Do not heat body excessively.

- (b) Remove the adhesive tape from the body.
 (c) Wipe off stains with cleaner.

2. If reusing moulding:

CLEAN MOULDING

- (a) Using a heat light, heat the moulding to 20 – 30 °C (68 – 86 °F).

NOTICE:

Do not heat moulding excessively.

- (b) Remove the adhesive tape from the moulding.
 (c) Wipe off stains with cleaner.
 (d) Apply a new adhesive tape to the moulding as shown in the illustration.

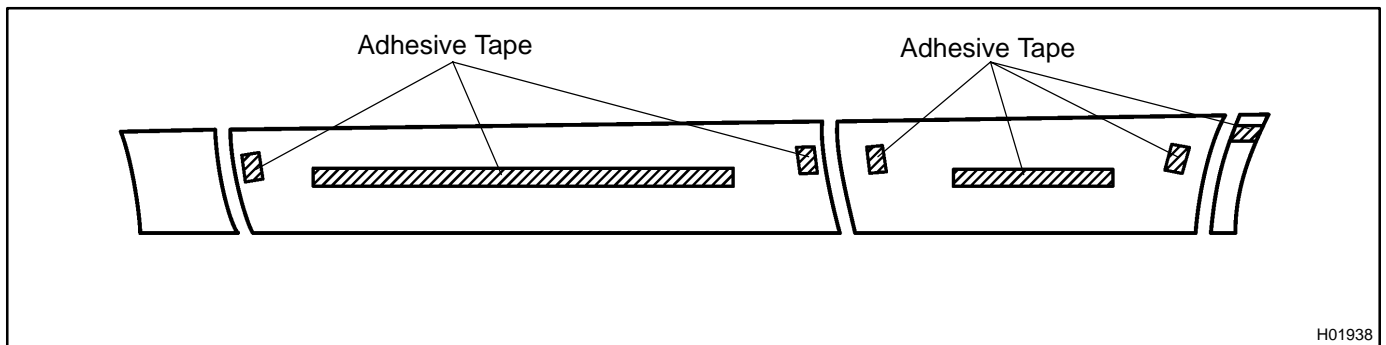

H01938

3. INSTALL MOULDING

- (a) Using a heat light, heat the body and moulding.

Body: 40 – 60 °C (104 – 140 °F)

Moulding: 20 – 30 °C (68 – 86 °F)

NOTICE:

Do not heat moulding excessively.

- (b) Lift the moulding release sheet from the face of moulding.

NOTICE:

When the moulding release sheet is removed, make sure that no dirt or dust can get onto the uncoated area.

- (c) Align the bosses with their corresponding holes in the body, and press firmly on the moulding.

NOTICE:

Do not apply excessive force onto the moulding, but steady pressure with your thumbs.