

INSTALLATION

1. INSTALL CRANKSHAFT TIMING PULLEY

- (a) Align the pulley set key with the key groove of the pulley.
- (b) Slide on the timing pulley facing the flange side inward.

NOTICE:

Do not scratch the sensor part of the crankshaft timing pulley.

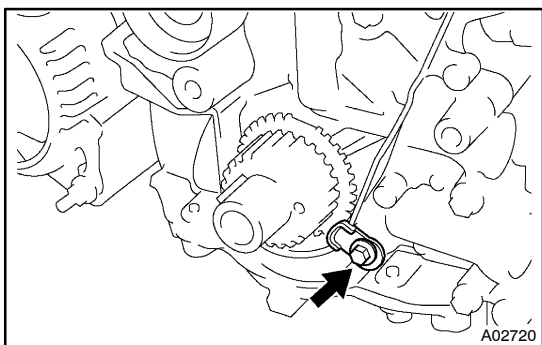

- (c) Install the timing belt plate with the bolt.
Torque: 8.0 N·m (80 kgf·cm, 71 in·lbf)

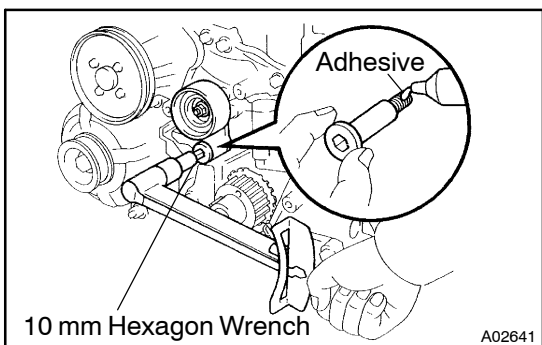

2. INSTALL IDLER PULLEY

- (a) Apply adhesive to 2 or 3 threads of the pivot bolt.
Adhesive: Part No. 08833-00080, THREE BOND 1344, LOCTITE 242 or equivalent
- (b) Using a 10 mm hexagon wrench, install the plate washer and pulley with the pivot bolt.
Torque: 35 N·m (350 kgf·cm, 26 ft·lbf)
- (c) Check that the pulley bracket moves smoothly.

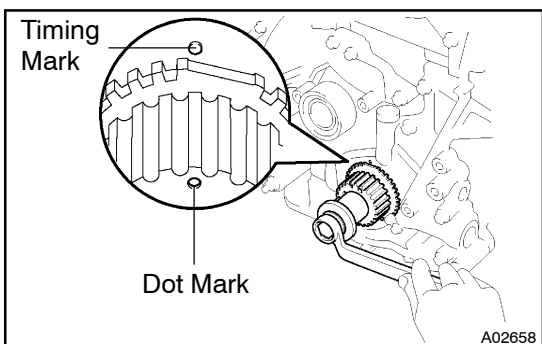

3. TEMPORARILY INSTALL TIMING BELT

NOTICE:

The engine should be cold.

- (a) Use the crankshaft pulley bolt to turn the crankshaft, and align the dot mark on the crankshaft timing pulley and the timing mark on the oil pump body.
- (b) Remove any oil or water on the crankshaft timing pulley and idler pulley, and keep them clean.

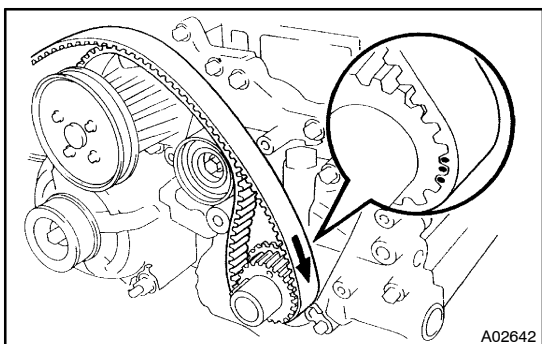

- (c) Install the timing belt on the crankshaft timing pulley and idler pulley.

HINT:

(When re-using timing belt):

Align the matchmarks of the crankshaft timing pulley and timing belt, and install the belt with the arrow pointing in the direction of engine revolution.

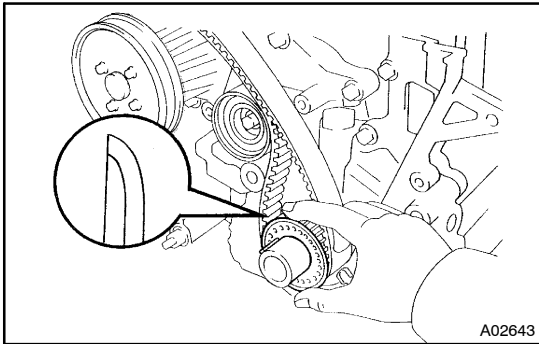
**4. INSTALL TIMING BELT GUIDE**

Install the guide, facing the cup side outward.

5. INSTALL NO.1 TIMING BELT COVER

- (a) Install the gasket to the timing belt cover.
- (b) Install the timing belt cover with the 5 bolts.

Torque: 8.0 N·m (80 kgf·cm, 71 in·lbf)

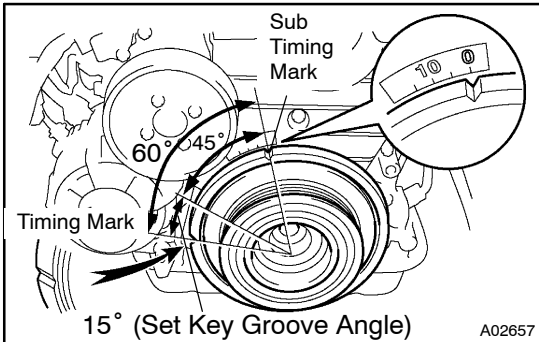
**6. INSTALL CRANKSHAFT PULLEY**

- (a) Align the pulley set key with the key groove of the pulley, and slide on the pulley.
- (b) Check that the sub timing mark (60° mark BTDC) of the crankshaft pulley is aligned with the timing mark "0" of the No.1 timing belt cover.

HINT:

At this time, the crankshaft pulley set key groove and the timing mark (TDC mark) of the crankshaft pulley are as shown the illustration.

- (c) Temporarily install the pulley bolt.

7. INSTALL VVT-i (INTAKE CAMSHAFT TIMING) PULLEY

- (a) Align the camshaft knock pin with the VVT-i pulley, and push the VVT-i pulley by hand until you feel it touch the bottom.

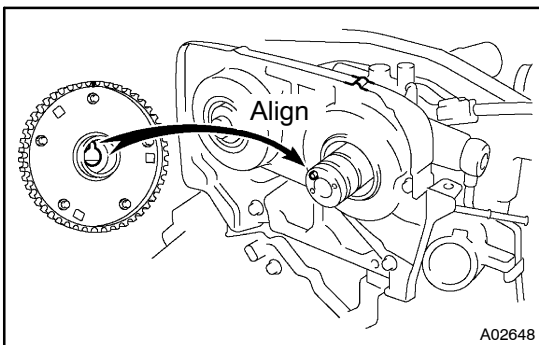

- (b) Check that the outer circumference of the VVT-i pulley easily rotates through 30°.

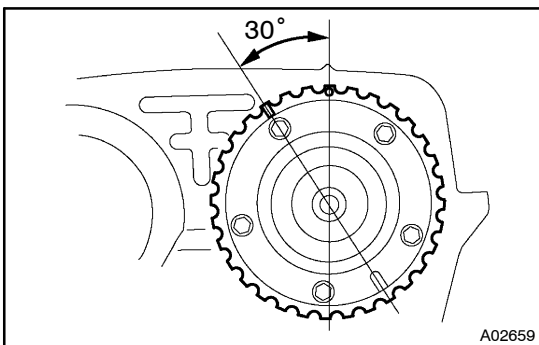

- (c) Holding the hexagon portion of the camshaft with a wrench.
- (d) Using a 10 mm hexagon wrench, and the set bolt.

Torque: 81 N·m (810 kgf·cm, 60 ft·lbf)
- (e) Using a 14 mm hexagon wrench, install the straight screw plug with the seal washer to the set bolt.

Torque: 15 N·m (150 kgf·cm, 11 ft·lbf)
- (f) Align the dot mark on the camshaft timing pulley with the timing mark of the No.4 timing belt cover.
- (g) Remove the wrench.

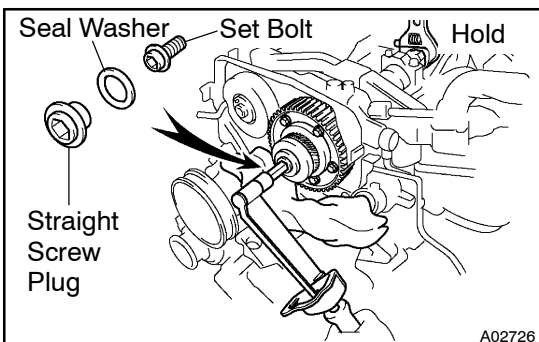

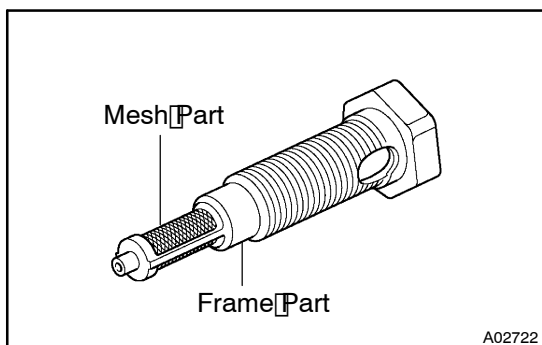

8. CONNECT NO.1 OIL PIPE

- (a) Install the union bolt to the oil control valve filter.

NOTICE:

In case of touching the filter, avoid holding the mesh part and holding the frame part.

- (b) Install the oil pipe with 2 new gasket and the union bolt to the No.3 camshaft bearing cap.

Torque: 55 N·m (550 kgf·cm, 41 ft·lbf)

9. INSTALL CAMSHAFT TIMING OIL CONTROL VALVE (See page FI-42)

10. INSTALL NO.1 CYLINDER HEAD COVER

- (a) Install the cylinder head and gasket with the 6 bolts and 2 nuts.

Torque: 8.5 N·m (85 kgf·cm, 7.5 in·lbf)

- (b) Install the high-tension cords and clamps with the 2 bolts.

Torque: 8.0 N·m (80 kgf·cm, 7.1 in·lbf)

- (c) Using a 5 mm hexagon wrench, install the engine wire protector with the bolt and nut.

11. INSTALL THROTTLE BODY AND INTAKE AIR CONNECTOR ASSEMBLY (See page EM-6)

12. INSTALL EXHAUST CAMSHAFT TIMING PULLEY

- (a) Align the camshaft knock pin with the groove on the pulley, and slide on the timing pulley.

- (b) Slide the timing pulley on the camshaft, facing the front mark forward.

- (c) Using SST, install the pulley bolt.

SST 09960-10010 (09962-01000, 09963-01000)

Torque: 81 N·m (810 kgf·cm, 60 ft·lbf)

- (d) Using SST, align the dot mark on the camshaft timing pulley with the timing mark of the No.4 timing belt cover.

SST 09960-10010 (09962-01000, 09963-01000)

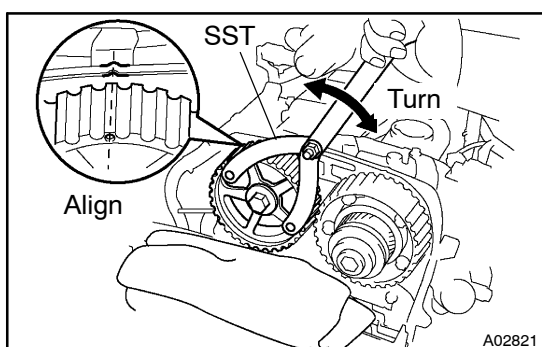
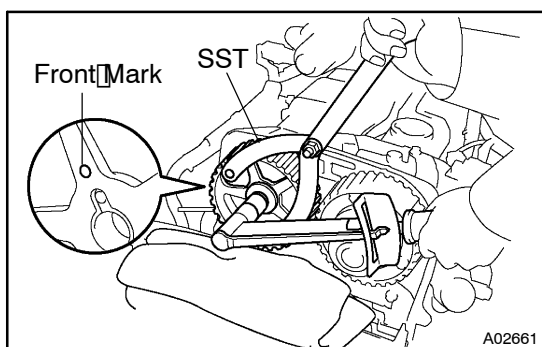
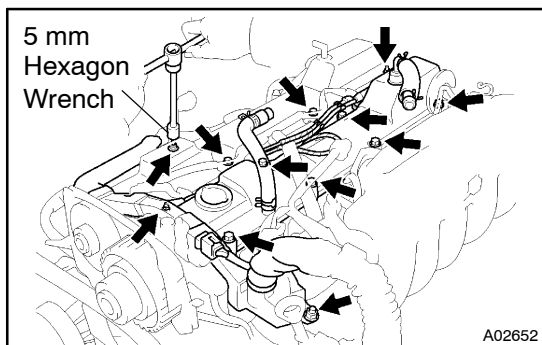

13. CONNECT TIMING BELT TO CAMSHAFT TIMING PULLEYS

HINT:

(When re-using timing belt):

- Check that the matchmark on the timing belt matches the end of the No.1 timing belt cover.

If the matchmark does not align, shift the meshing of the timing belt and crankshaft timing pulley until they align.

- Align the matchmarks of the timing belt and camshaft timing pulleys.

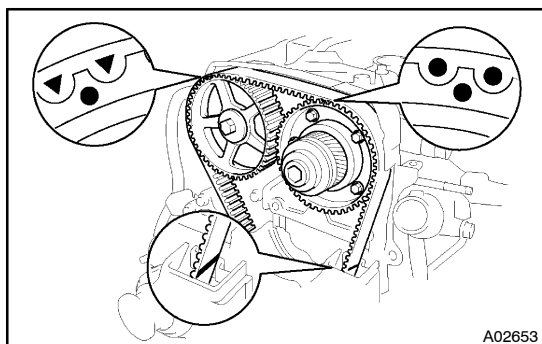

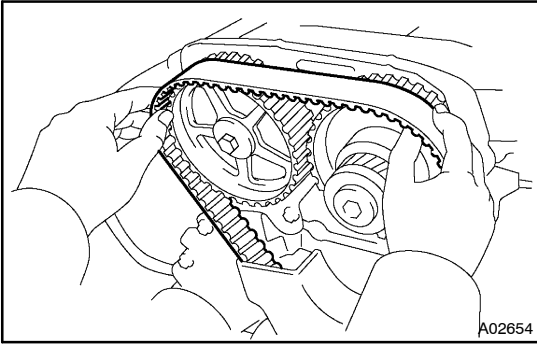

- (a) Remove any oil or water on the camshaft timing pulley, and keep it clean.
- (b) Install the timing belt, checking the tension between the crankshaft timing pulley and intake camshaft timing pulley.

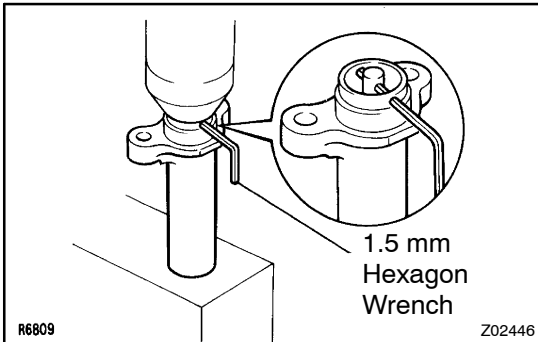

14. SET TIMING BELT TENSIONER

- (a) Using a press, slowly press in the push rod using 981 – 9,807 N (100 – 1,000 kgf, 220 – 2,205 lbf) of force.
- (b) Align the holes of the push rod and housing, pass a 1.5 mm hexagon wrench through the holes to keep the push rod retracted.
- (c) Release the press.

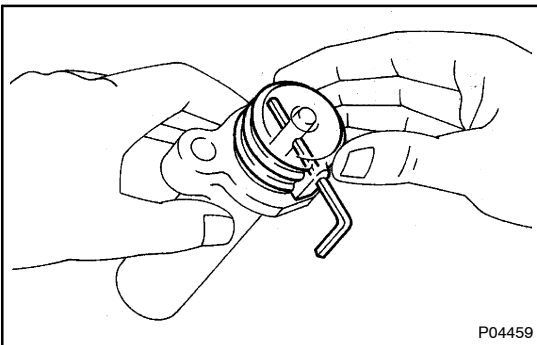

- (d) Install the dust boot onto the tensioner.

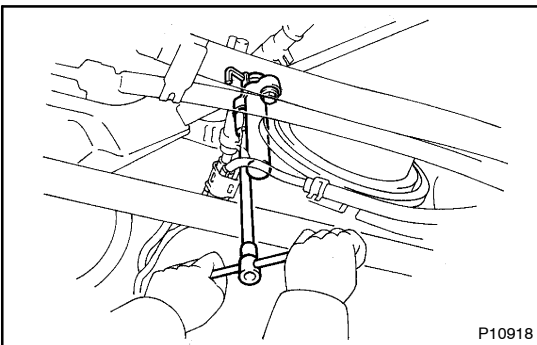

15. INSTALL TIMING BELT TENSIONER

- (a) Temporarily install the tensioner with the 2 bolts.
- (b) Alternately tighten the 2 bolts.

Torque: 27 N·m (270 kgf·cm, 20 ft·lbf)

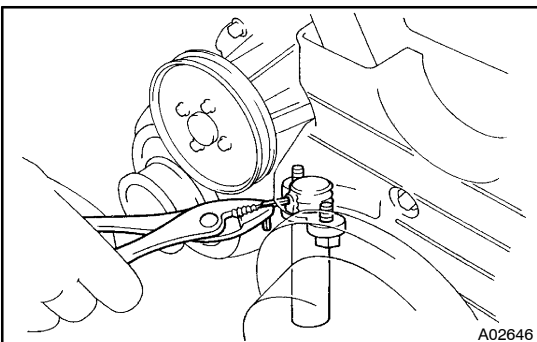

- (c) Remove the 1.5 mm hexagon wrench from the tensioner with pliers.

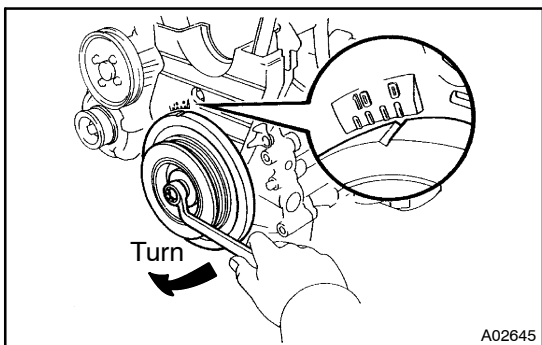
**16. CHECK VALVE TIMING**

- (a) Slowly turn the crankshaft pulley 2 revolutions from TDC to TDC.

NOTICE:

Always turn the crankshaft clockwise.

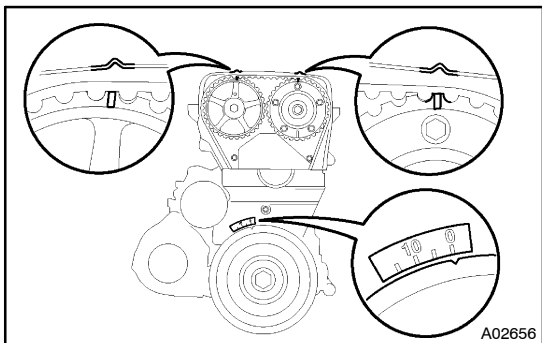

- (b) Check that each pulley aligns with the timing marks as shown in the illustration.

If the marks do not align, remove the timing belt and reinstall it.

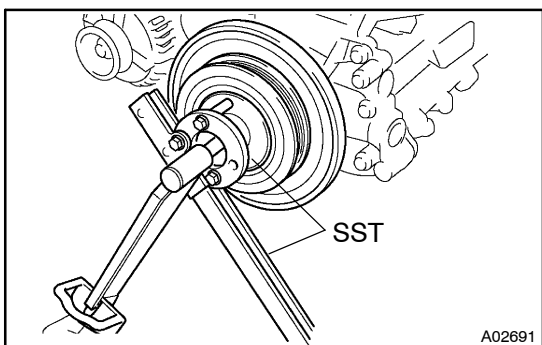
**17. TIGHTEN CRANKSHAFT PULLEY BOLT**

Using SST, install the pulley bolt.

SST 09213-70010, 09330-00021

Torque: 330 N·m (3,300 kgf·cm, 243 ft·lbf)

18. INSTALL DRIVE BELT TENSIONER

Install the tensioner with the 3 bolts.

Torque: 21 N·m (210 kgf·cm, 15 ft·lbf)

NOTICE:

Be careful not to drop the bolts inside the timing belt cover.

19. INSTALL NO.2 TIMING BELT COVER

- (a) Install the gasket on the timing belt cover.
 (b) Using a 5 mm hexagon wrench, install the timing belt cover with the 3 bolts.

Torque: 8.0 N·m (80 kgf·cm, 71 in·lbf)

20. INSTALL NO.3 TIMING BELT COVER

- (a) Install the gasket on the timing belt cover.
 (b) Using a 5 mm hexagon wrench, install the timing belt cover with the 4 bolts.

Torque: 8.0 N·m (80 kgf·cm, 71 in·lbf)

- (c) Install the oil filler cap.

21. INSTALL PS PUMP AND FRONT BRACKET

- (a) Temporarily install the vane pump to the bracket.
 (b) Install the plate washer and front bracket with the 3 bolts.

Torque:

A bolt: 58 N·m (590 kgf·cm, 43 ft·lbf)

B bolt: 52 N·m (530 kgf·cm, 38 ft·lbf)

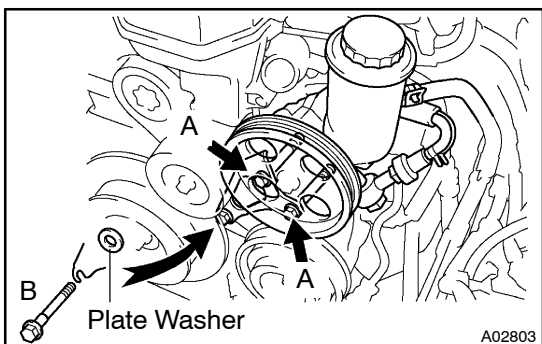

22. INSTALL DRIVE BELT (See page CH-16)
23. INSTALL RADIATOR ASSEMBLY (See page CO-21)
24. FILL ENGINE WITH COOLANT
25. START ENGINE CHECK FOR LEAKS
26. INSTALL ENGINE UNDER COVER
27. ROAD TEST

Check for abnormal noise, shock, slippage, correct shift points and smooth operation.

28. RECHECK ENGINE COOLANT LEVEL