

DTC	B2796/99	No Communication in Immobiliser system
------------	-----------------	---

CIRCUIT DESCRIPTION

DTC No.	DTC Detecting Condition	Trouble Area
B2796/99	No communication	<ul style="list-style-type: none"> • Key • Transponder Key Coil • Transponder Key Amplifier • Wire harness • Engine and ECT ECU

WIRING DIAGRAM

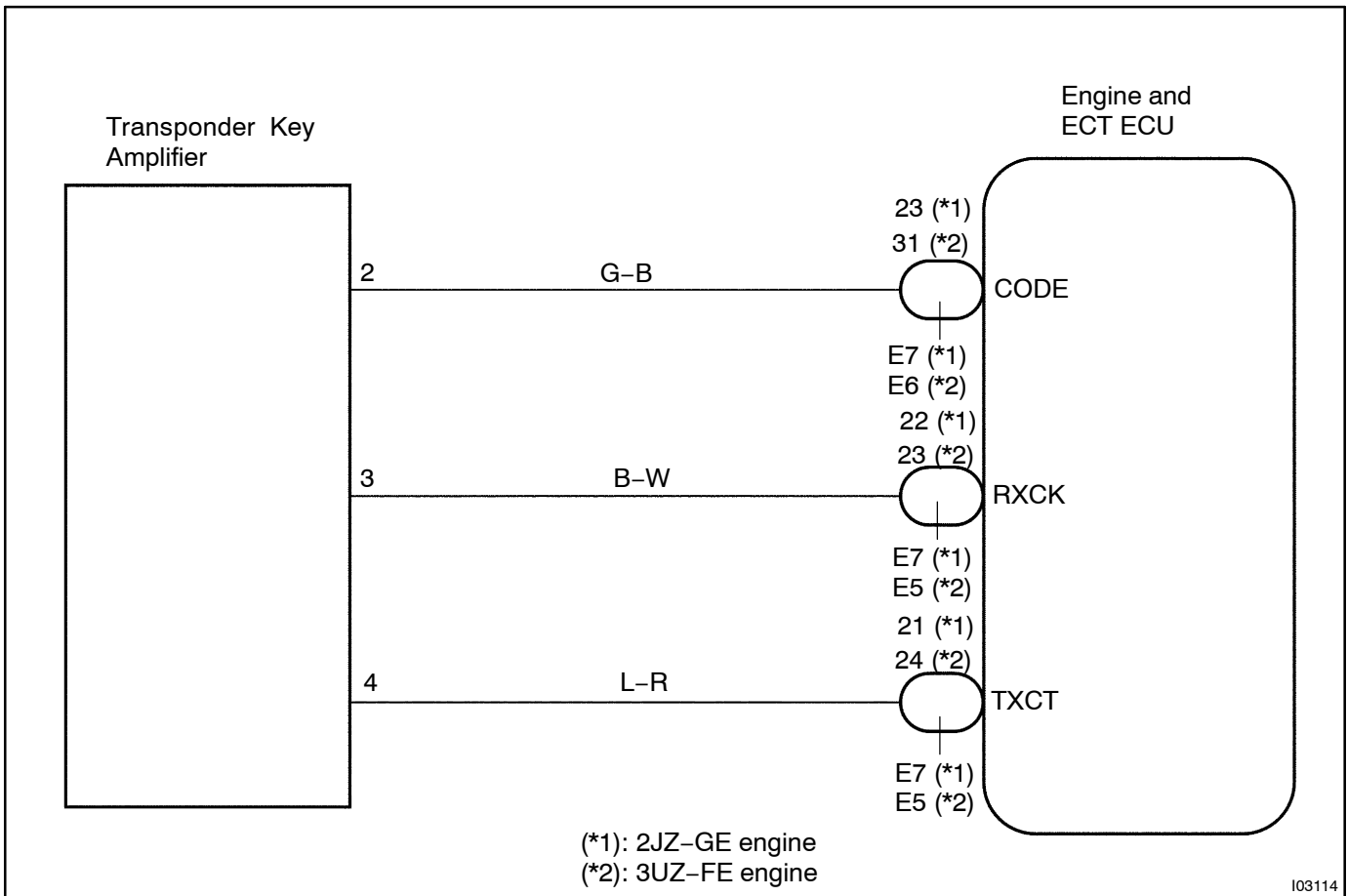

INSPECTION PROCEDURE

1 Check transponder key coil (See Pub. No. RM588E on page BE-253).

NG

Replace transponder key coil.

OK

2 Check harness and connector between transponder key amplifier and ECU.

NG

Repair or replace harness and connector.

OK

3 Does it operate normally after replacement of transponder key amplifier?

Yes

Replace transponder key amplifier.

No

Replace ECU.