

## REPLACEMENT

### 1. REPLACE VALVE GUIDE BUSHINGS

(a) Gradually heat the cylinder head to 80 – 100°C (176 – 212°F).

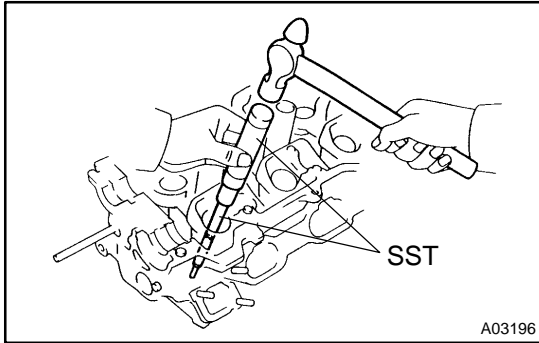

(b) Using SST and a hammer, tap out the guide bushing.  
SST 09201-01055, 09950-70010 (09951-07100)

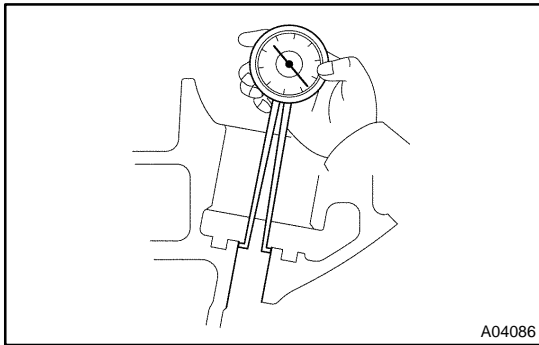

(c) Using a caliper gauge, measure the bushing bore diameter of the cylinder head.

Both intake and exhaust

Bushing bore diameter mm (in.)	Bushing size
10.285 – 10.306 (0.4049 – 0.4057)	Use STD
10.335 – 10.356 (0.4069 – 0.4077)	Use O/S STD

(d) Select a new guide bushing (STD or O/S 0.05).

If the bushing bore diameter of the cylinder head is greater than 10.306 mm (0.4057 in.), machine the bushing bore to this dimension:

**10.335 – 10.356 mm (0.4069 – 0.4077 in.)**

If the bushing bore diameter of the cylinder head is greater than 10.356 mm (0.4077 in.), replace the cylinder head.

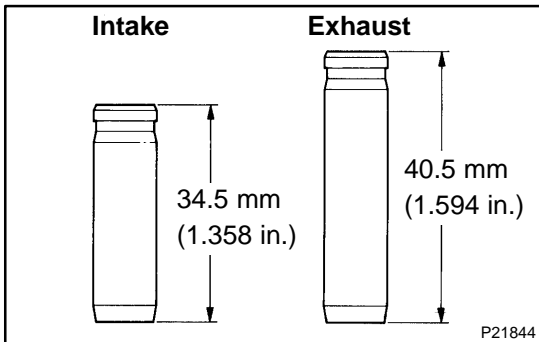

### HINT:

Different the bushings are used for the intake and exhaust.

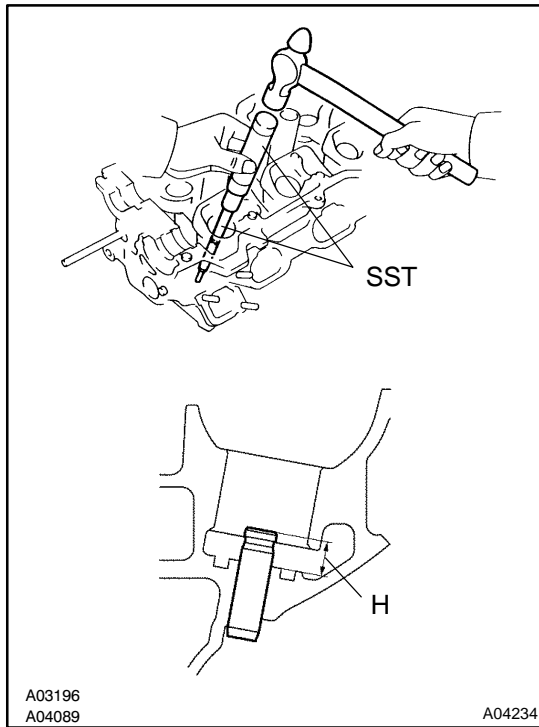

- (e) Gradually heat the cylinder head to 80 – 100°C (176 – 212°F).
- (f) Using SST and a hammer, tap in a new guide bushing to the specified protrusion height.

SST 09201-01055, 09950-70010 (09951-07100)

**Protrusion height (H):**

Intake	9.2 – 9.8 mm (0.362 – 0.386 in.)
Exhaust	8.2 – 8.8 mm (0.323 – 0.346 in.)

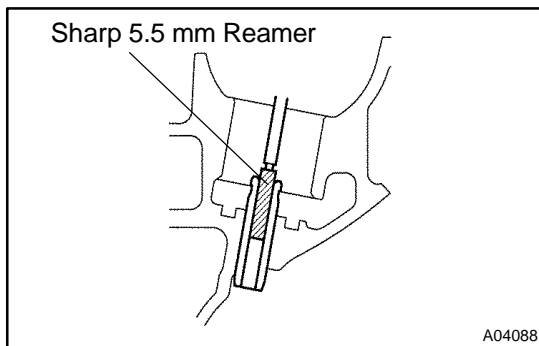

- (g) Using a sharp 5.5 mm reamer, ream the guide bushing to obtain the standard specified clearance (See page EM-46) between the guide bushing and valve stem.

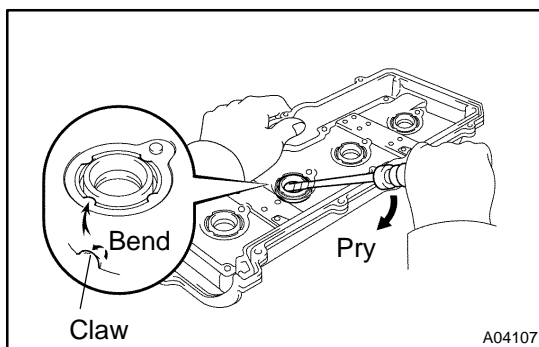

**2. REPLACE SPARK PLUG TUBE GASKETS**

- (a) Bend the 4 ventilation case claws installed on the cylinder head cover to an angle of 90° or more.
- (b) Using a screwdriver, pry out the gasket.

**NOTICE:**

**Be careful not to damage the cylinder head cover. Tape the screwdriver tip.**

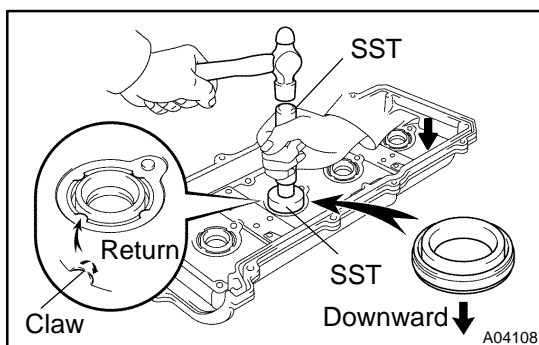

- (c) Using SST and a hammer, tap in a new gasket until its surface is flush with the upper edge of the cylinder head cover.

SST 09950-60010 (09551-00240, 09951-00440, 09952-06010), 09950-70010 (09951-07100)

**NOTICE:**

**Be careful of the installation direction.**

- (d) Apply a light coat of MP grease to the gasket lip.
- (e) Return the 4 ventilation case claws to its original position.