

# CYLINDER HEAD COMPONENTS

EMDZ-01

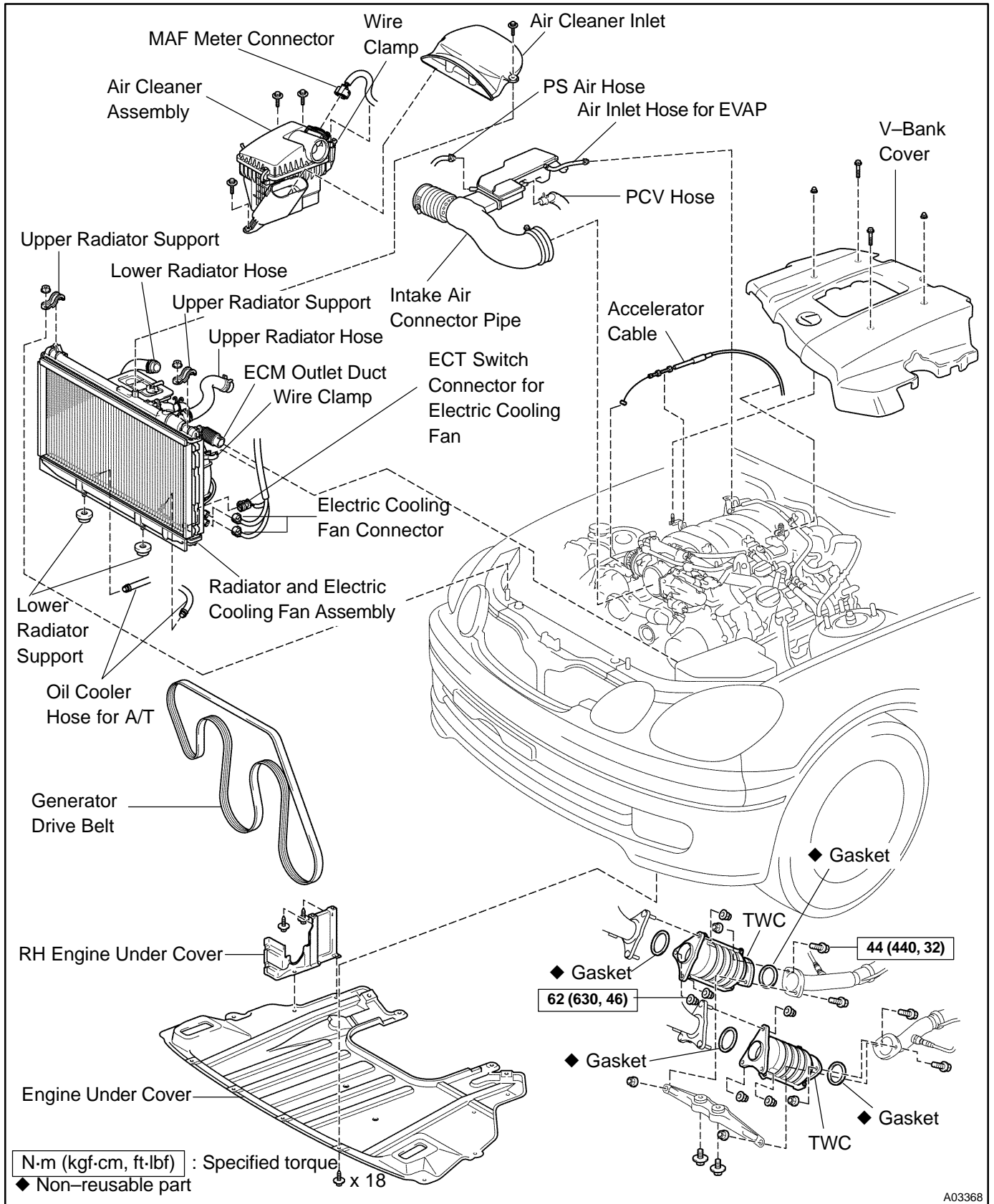

A03368

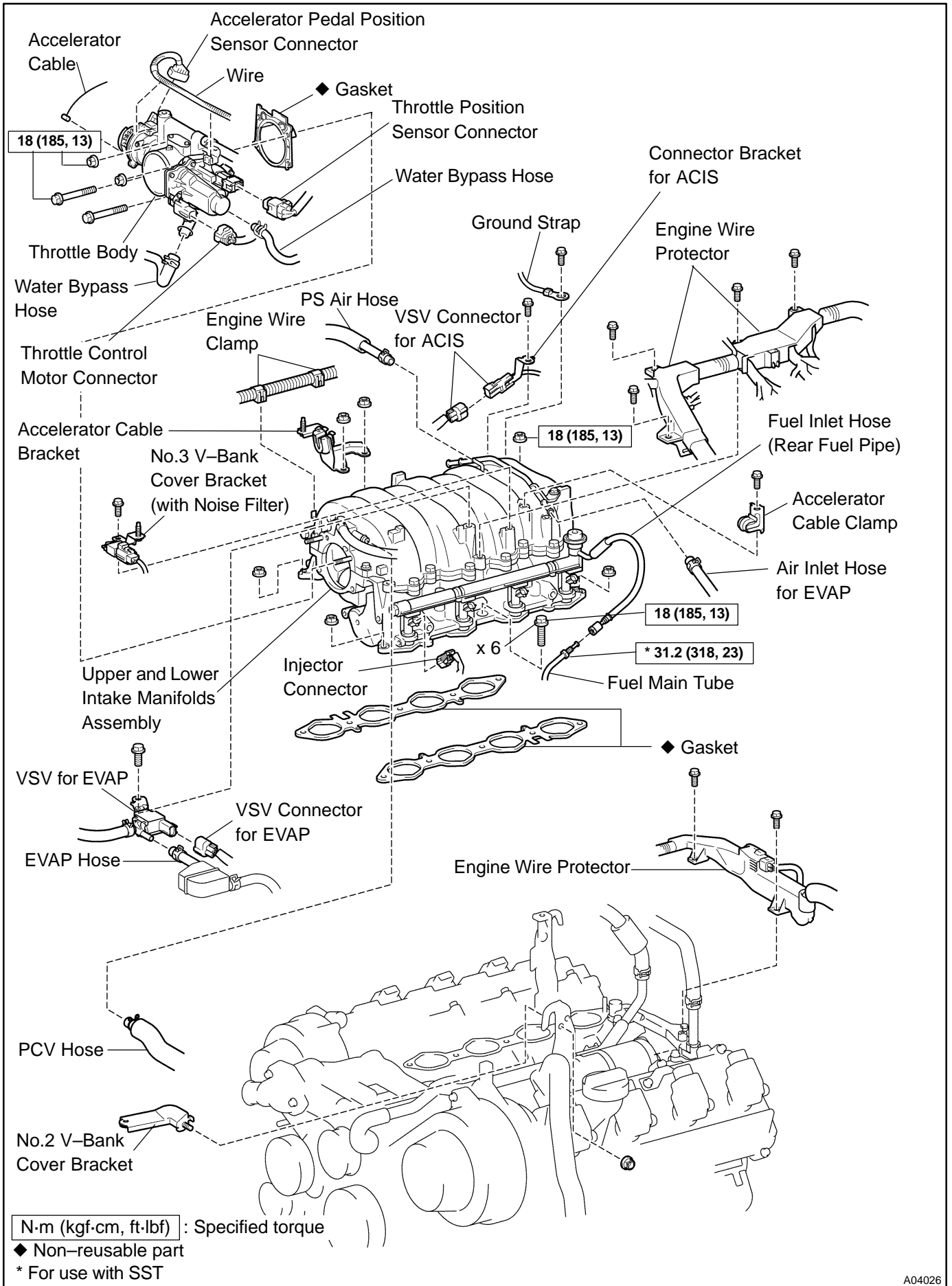

A04026

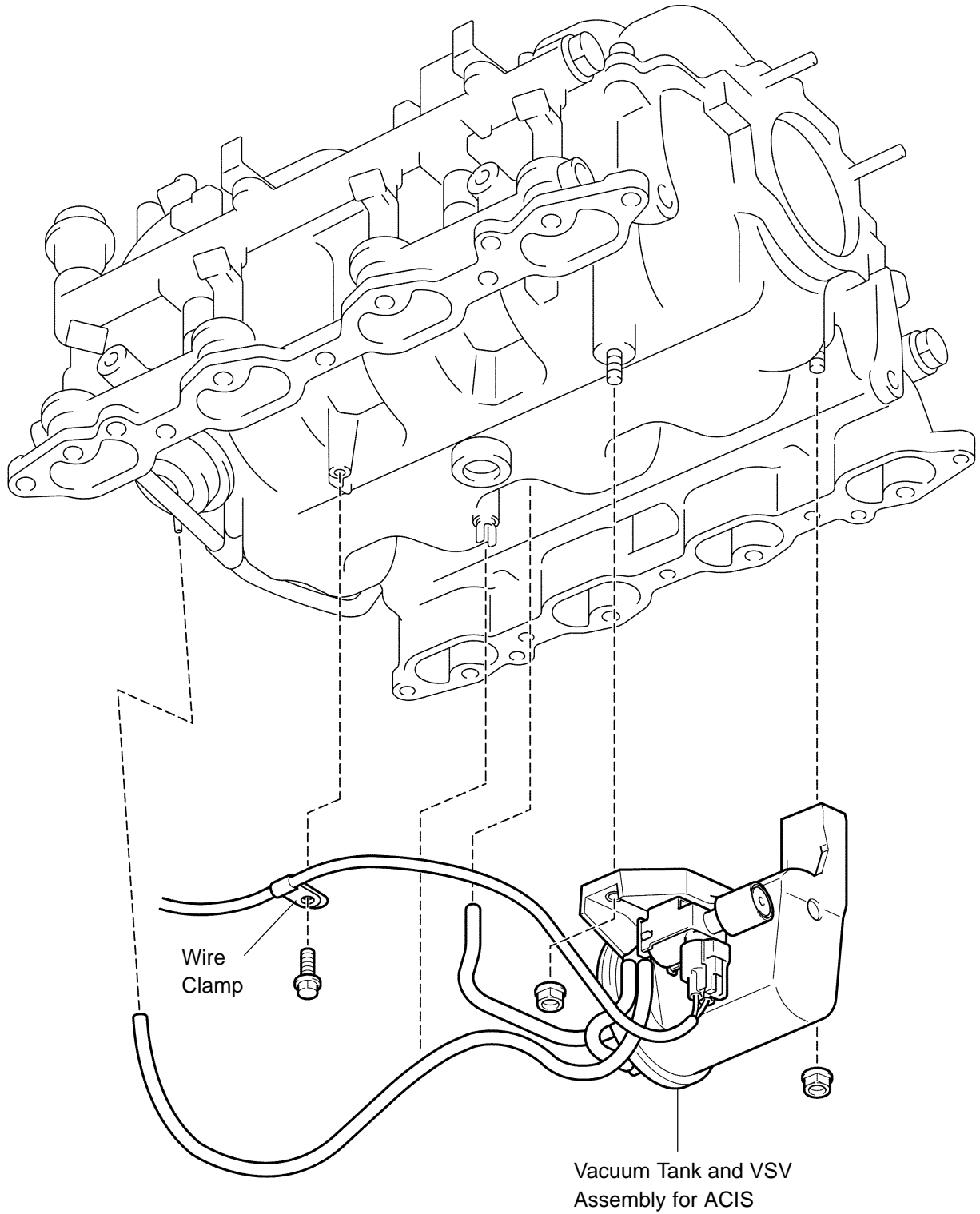

A03333

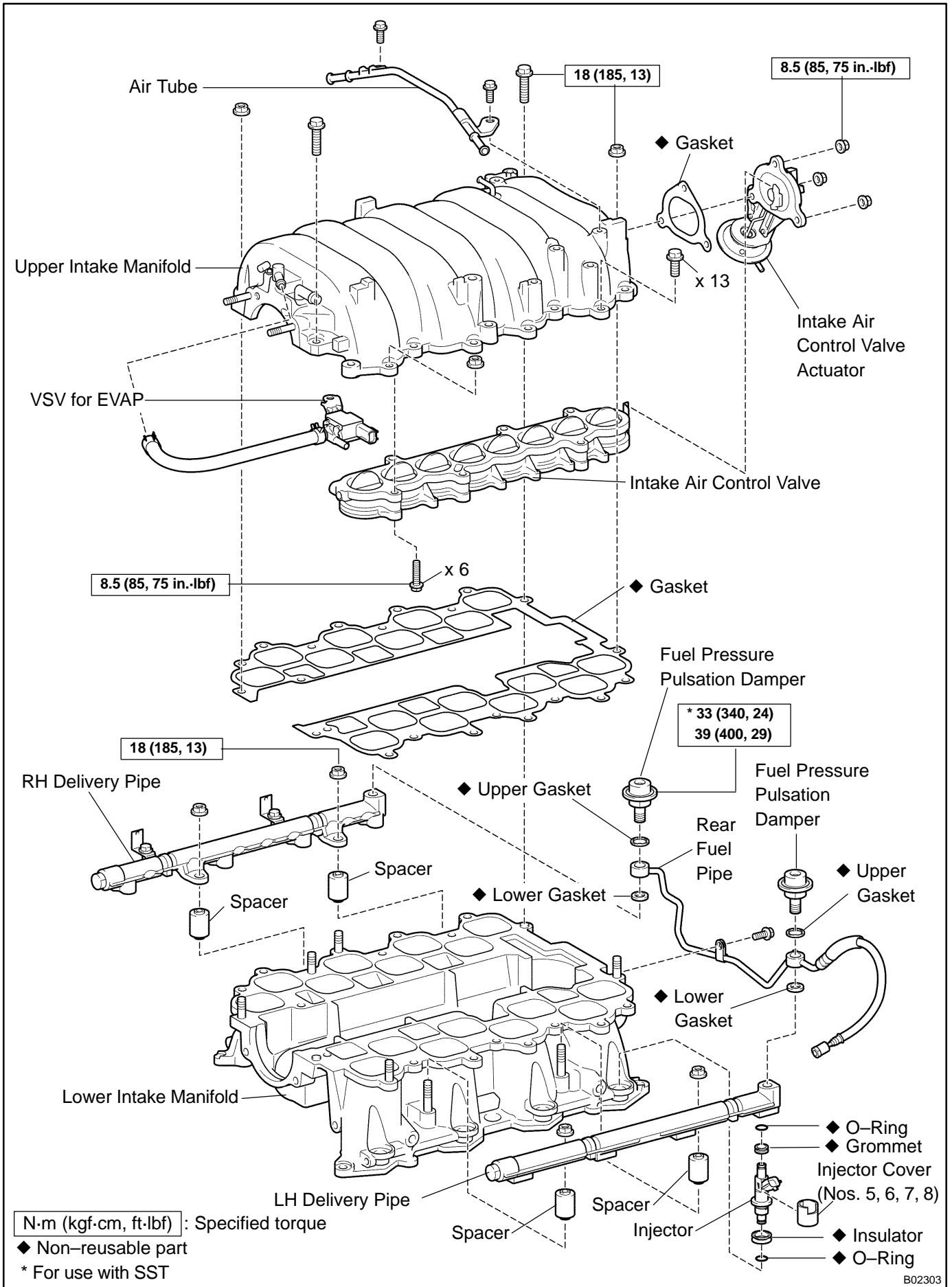

ENGINE MECHANICAL (1UZ-FE) - CYLINDER HEAD

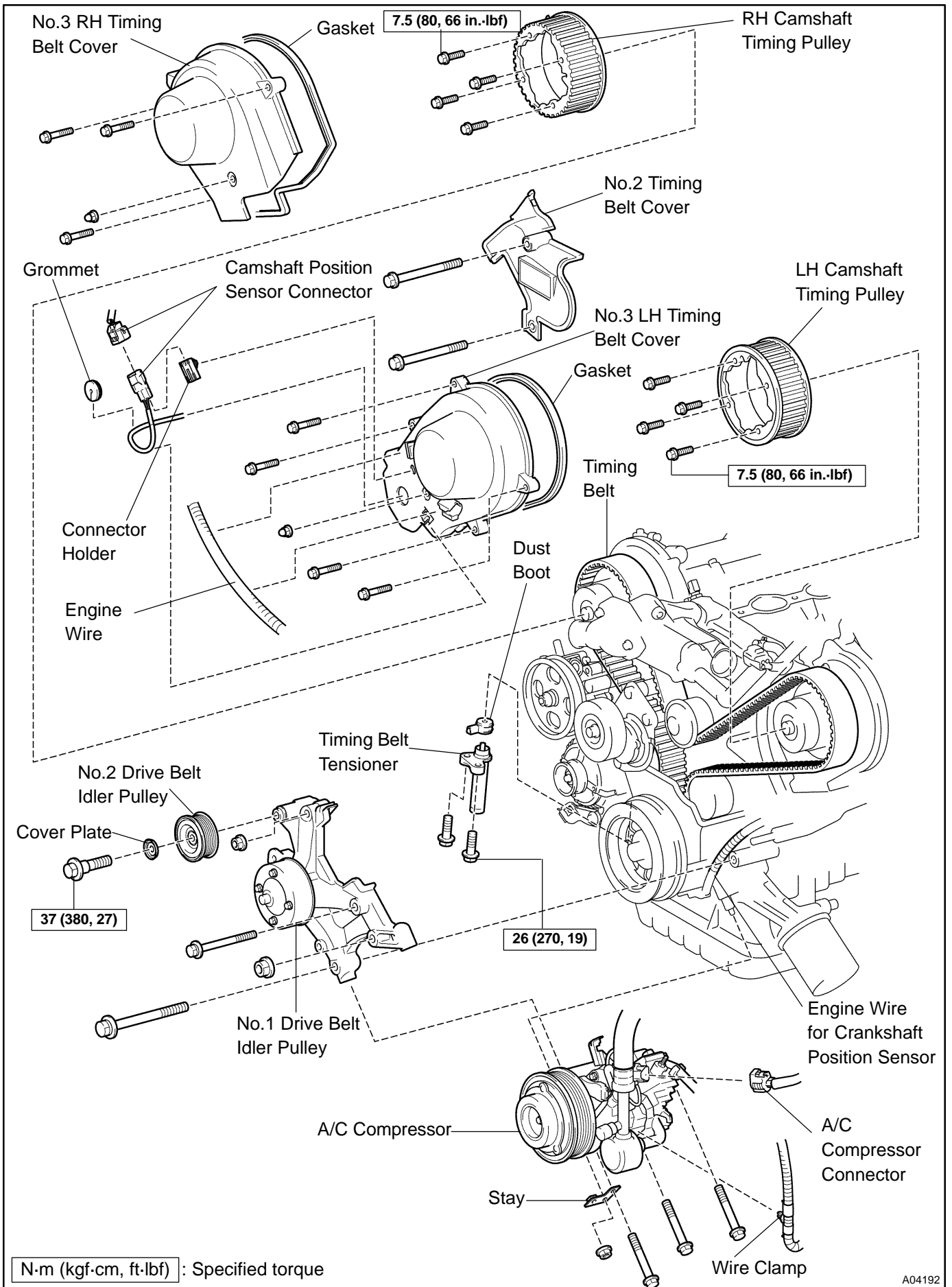

N·m (kgf·cm, ft·lbf) : Specified torque

A04192

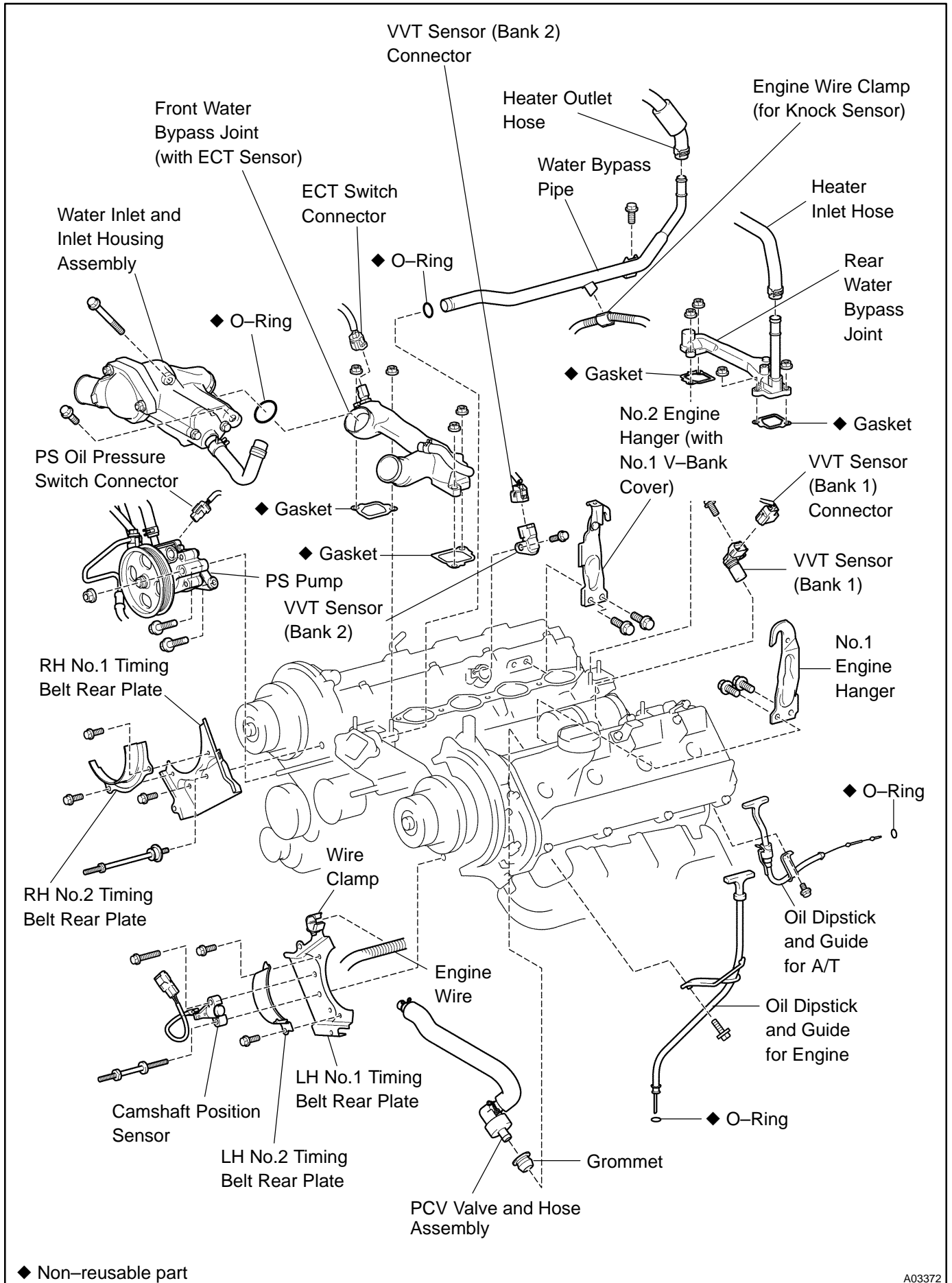

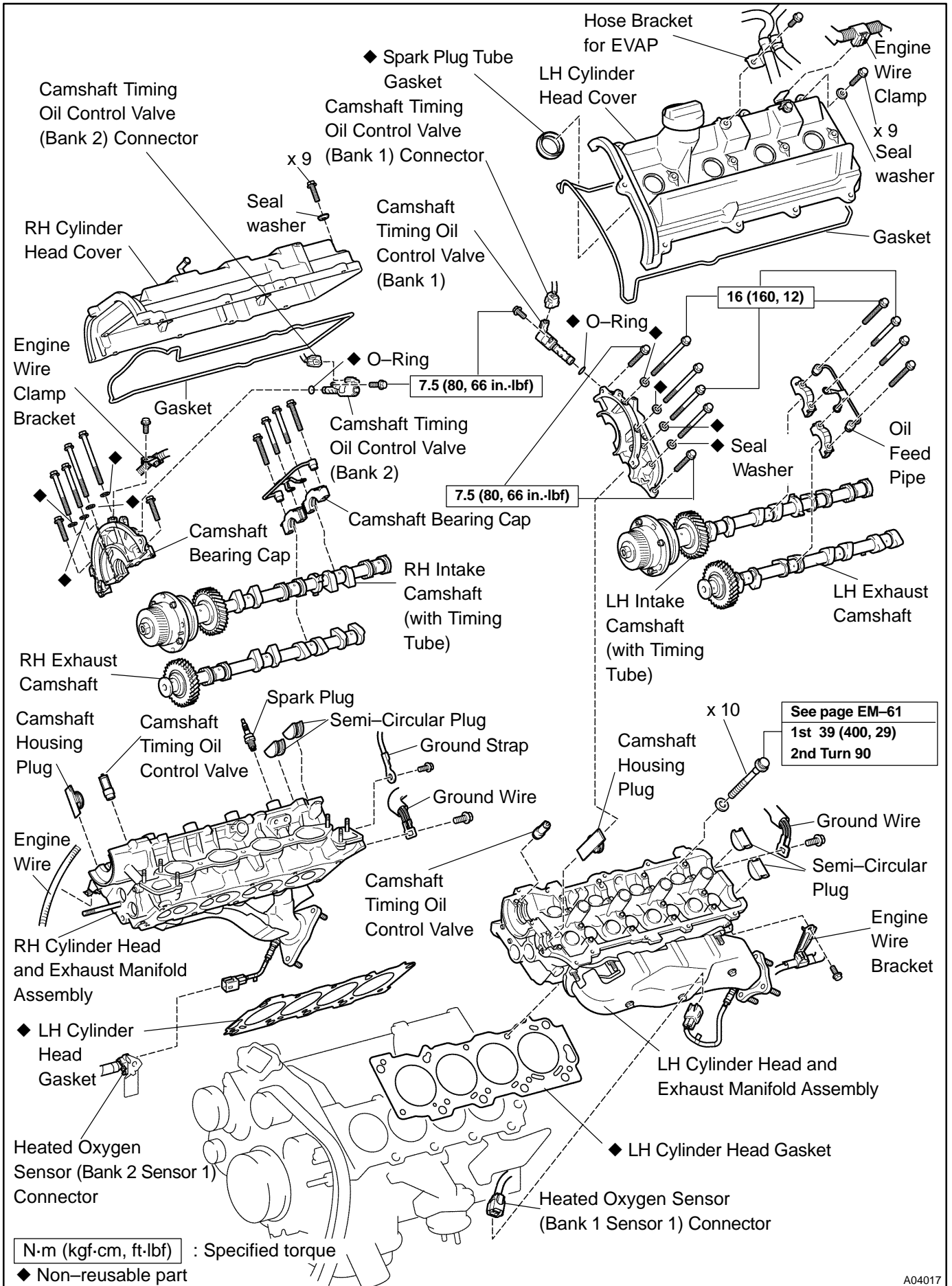

A04017

