

INSPECTION

1. CLEAN TOP SURFACES OF PISTONS AND CYLINDER BLOCK

- (a) Turn the crankshaft, and bring each piston to top dead center (TDC). Using a gasket scraper, remove all the carbon from the piston top surface.

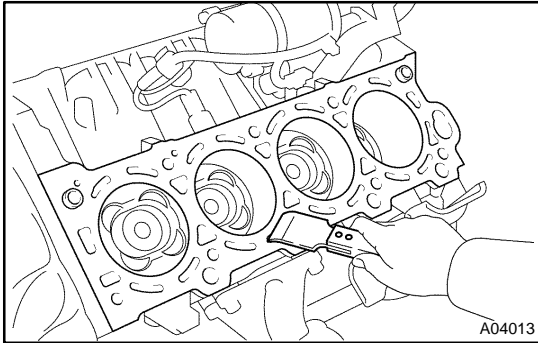

- (b) Using a gasket scraper, remove all the gasket material from the cylinder block surface.

- (c) Using compressed air, blow carbon and oil from the bolt holes.

CAUTION:

Protect your eyes when using high pressure compressed air.

2. INSPECT TOP SURFACE OF CYLINDER BLOCK FOR FLATNESS (See page EM-102)

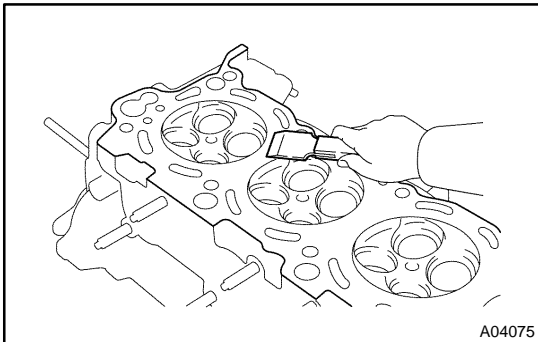

3. CLEAN CYLINDER HEAD

- (a) Using a gasket scraper, remove all the gasket material from the cylinder block contact surface.

NOTICE:

Be careful not to scratch the cylinder block contact surface.

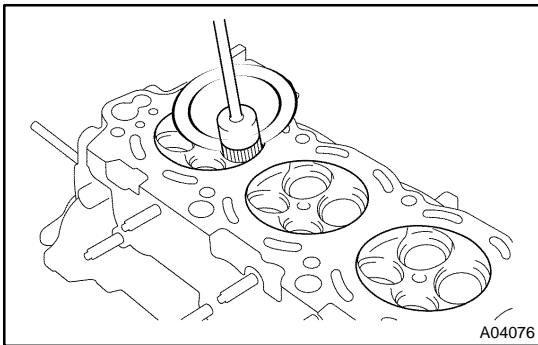

- (b) Using a wire brush, remove all the carbon from the combustion chambers.

NOTICE:

Be careful not to scratch the cylinder block contact surface.

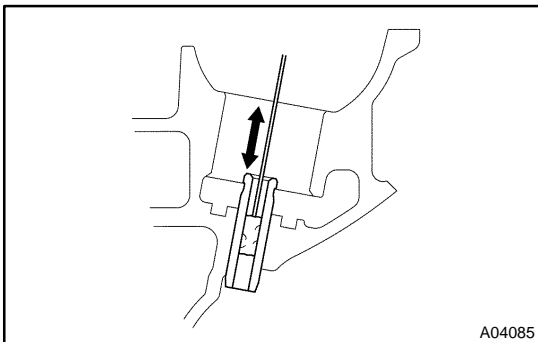

- (c) Using a valve guide bushing brush and solvent, clean all the guide bushings.

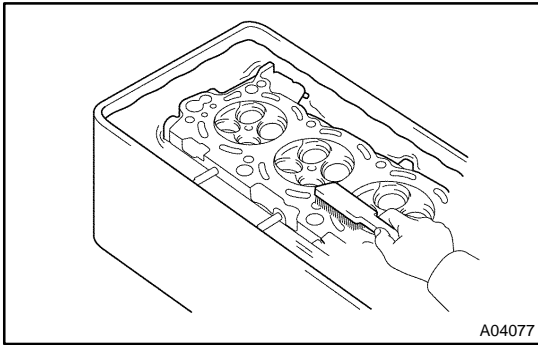

- (d) Using a soft brush and solvent, thoroughly clean the cylinder head.

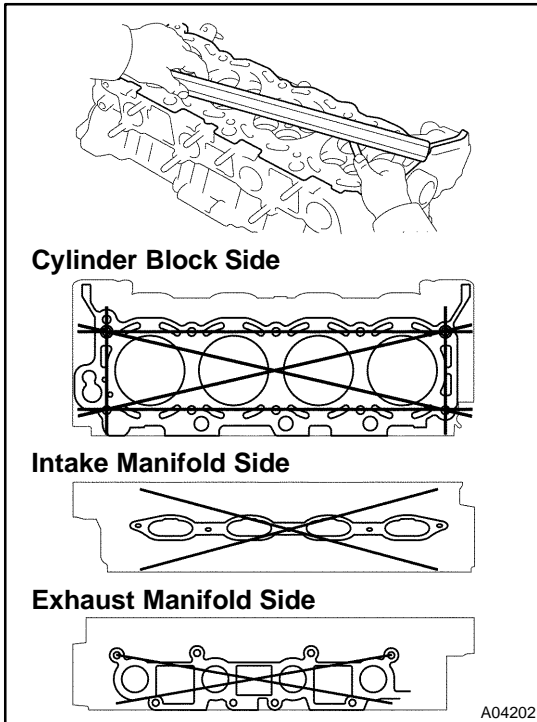

4. INSPECT CYLINDER HEAD

- (a) Inspect for flatness.

Using a precision straight edge and feeler gauge, measure the surfaces contacting the cylinder block and the manifolds for warpage.

Maximum warpage: 0.10 mm (0.0039 in.)

If warpage is greater than maximum, replace the cylinder head.

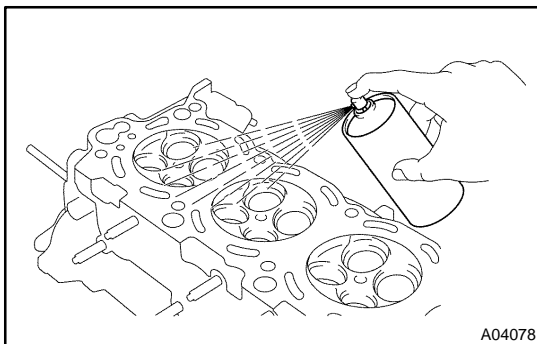

- (b) Inspect for cracks.

Using a dye penetrant, check the combustion chamber, intake ports, exhaust ports and cylinder block surface for cracks.

If cracked, replace the cylinder head.

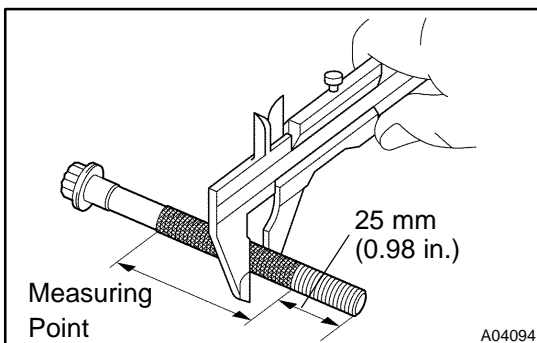

- (c) Using vernier calipers, measure the thread outside diameter of the cylinder head bolt.

Standard outside diameter:

9.770 – 9.960 mm (0.3846 – 0.3921 in.)

Minimum outside diameter: 9.60 mm (0.3780 in.)

If the diameter is less than minimum, replace the bolt.

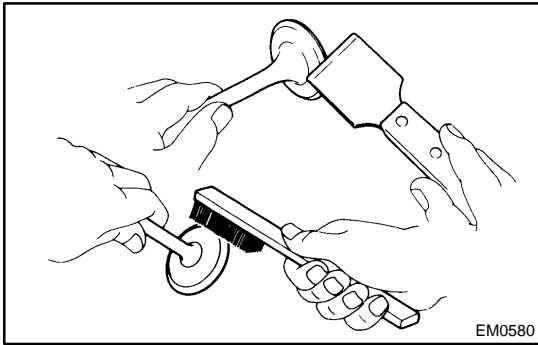

EM0580

5. CLEAN VALVES

- (a) Using a gasket scraper, chip off any carbon from the valve head.
- (b) Using a wire brush, thoroughly clean the valve.

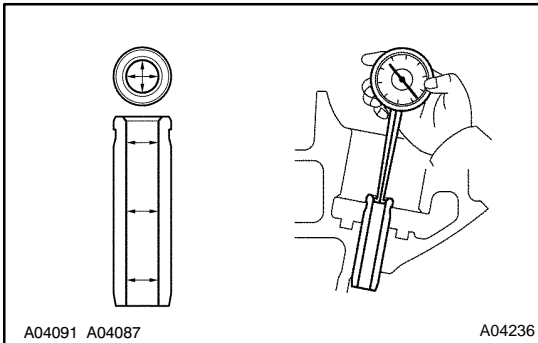

A04091 A04087

A04236

6. INSPECT VALVE STEMS AND GUIDE BUSHINGS

- (a) Using a caliper gauge, measure the inside diameter of the guide bushing.

Bushing inside diameter:
5.510 – 5.530 mm (0.2169 – 0.2177 in.)

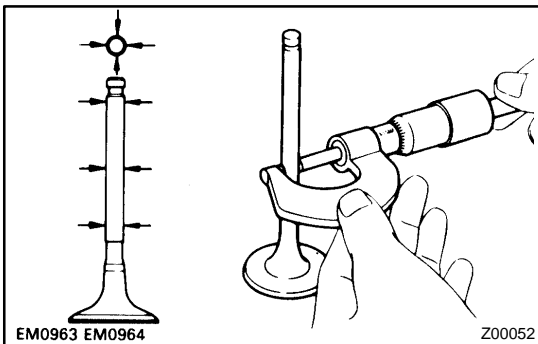

EM0963 EM0964

Z00052

- (b) Using a micrometer, measure the diameter of the valve stem.

Valve stem diameter:

Intake	5.470 – 5.485 mm (0.2154 – 0.2159 in.)
Exhaust	5.465 – 5.480 mm (0.2152 – 0.2157 in.)

- (c) Subtract the valve stem diameter measurement from the guide bushing inside diameter measurement.

Standard oil clearance:

Intake	0.025 – 0.060 mm (0.0010 – 0.0024 in.)
Exhaust	0.030 – 0.065 mm (0.0012 – 0.0026 in.)

Maximum oil clearance:

Intake	0.08 mm (0.0031 in.)
Exhaust	0.10 mm (0.0039 in.)

If the clearance is greater than maximum, replace the valve and guide bushing. (See page EM-57)

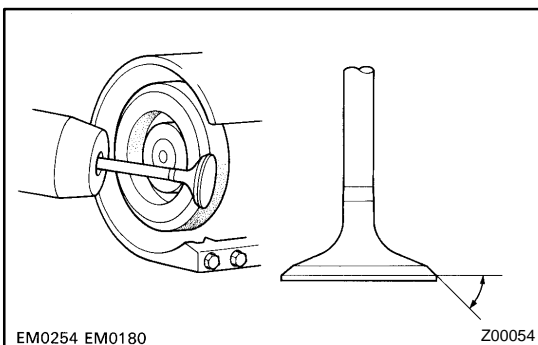

EM0254 EM0180

Z00054

7. INSPECT AND GRIND VALVES

- (a) Grind the valve enough to remove pits and carbon.
- (b) Check that the valve is ground to the correct valve face angle.

Valve face angle: 44.5°

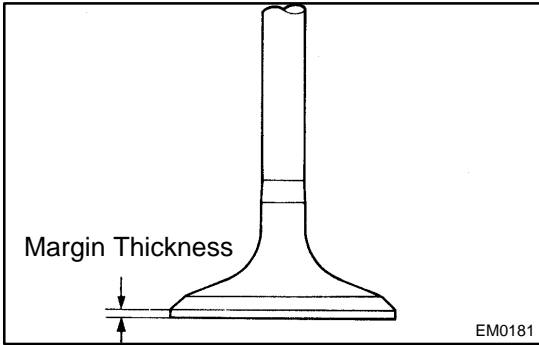

- (c) Check the valve head margin thickness.
Standard margin thickness: 1.0 mm (0.039 in.)
Minimum margin thickness: 0.5 mm (0.020 in.)
 If the margin thickness is less than minimum, replace the valve.

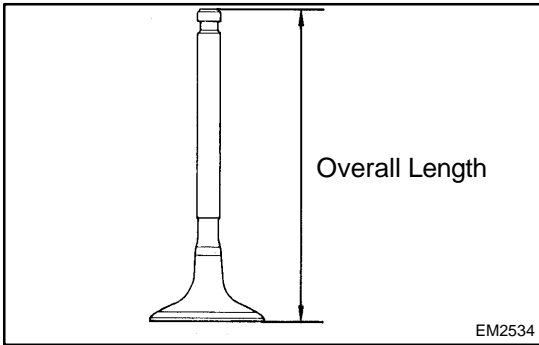

- (d) Check the valve overall length.
Standard overall length:

Intake	94.80 – 95.30 mm (3.7323 – 3.7520 in.)
Exhaust	94.85 – 95.35 mm (3.7342 – 3.7539 in.)

Minimum overall length:

Intake	94.55 mm (3.7224 in.)
Exhaust	94.60 mm (3.7244 in.)

If the overall length is less than minimum, replace the valve.

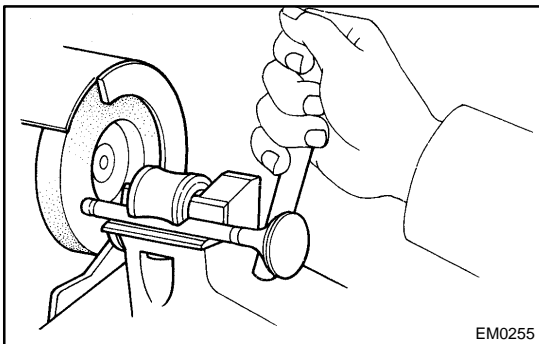

- (e) Check the surface of the valve stem tip for wear.
 If the valve stem tip is worn, resurface the tip with a grinder or replace the valve.

NOTICE:

Do not grind off more than minimum.

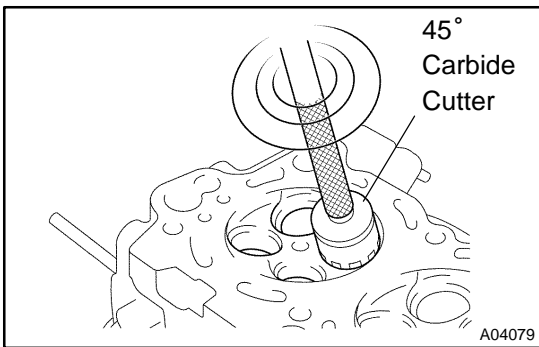

8. INSPECT AND CLEAN VALVE SEATS

- (a) Using a 45° carbide cutter, resurface the valve seats. Remove only enough metal to clean the seats.

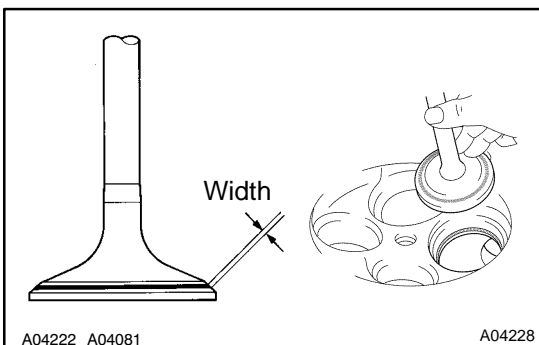

- (b) Check the valve seating position.
 Apply a light coat of prussian blue (or white lead) to the valve face. Lightly press the valve against the seat. Do not rotate valve.
- (c) Check the valve face and seat for the following:
- If blue appears 360° around the face, the valve is concentric. If not, replace the valve.
 - If blue appears 360° around the valve seat, the guide and face are concentric. If not, resurface the seat.

- Check that the seat contact is in the middle of the valve face with these width:
1.0 – 1.4 mm (0.039 – 0.055 in.)

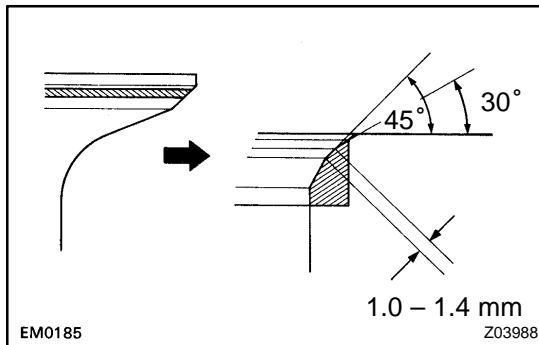

If not, correct the valve seats as follows:

- If the seating is too high on the valve face, use 30° and 45° cutters to correct the seat.

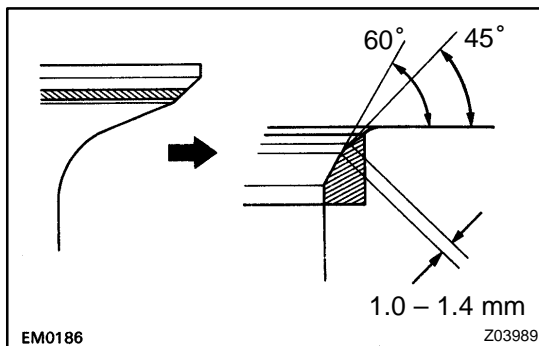

- If the seating is too low on the valve face, use 60° and 45° cutters to correct the seat.

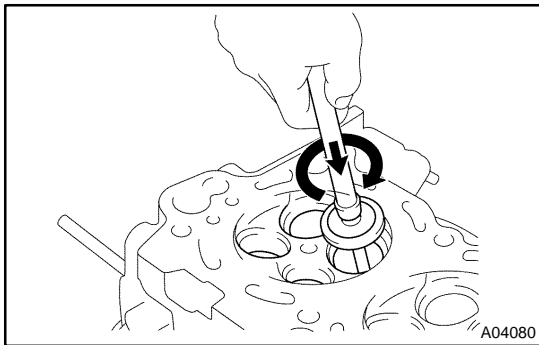

- Hand-lap the valve and valve seat with an abrasive compound.
- After hand-lapping, clean the valve and valve seat.

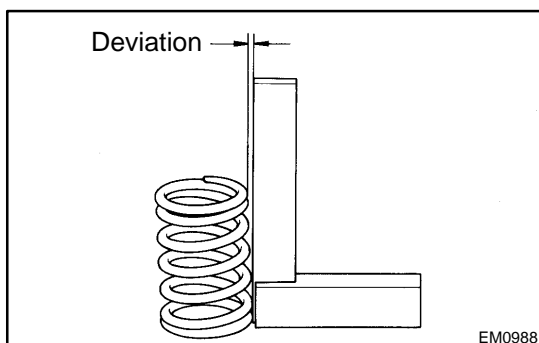

9. INSPECT VALVE SPRINGS

- Using a steel square, measure the deviation of the valve spring.

Maximum deviation: 2.0 mm (0.079 in.)

If the deviation is greater than maximum, replace the valve spring.

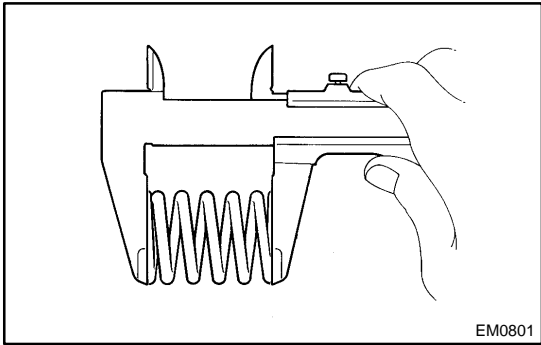

- (b) Using vernier calipers, measure the free length of the valve spring.
Free length: 54.05 – 54.15 mm (2.1279 – 2.1319 in.)
 If the free length is not as specified, replace the valve spring.

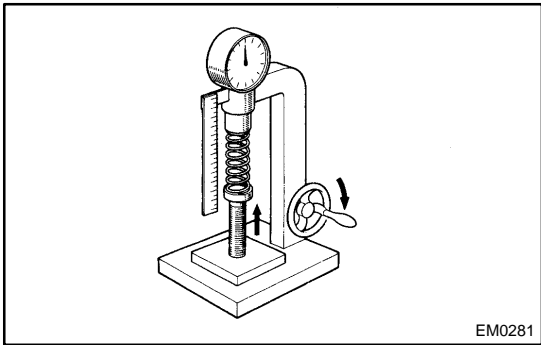

- (c) Using a spring tester, measure the tension of the valve spring at the specified installed length.
Installed tension:
204 – 226 N (20.8 – 23.0 kgf, 45.9 – 50.7 lbf)
at 35.04 mm (1.3795 in.)
 If the installed tension is not as specified, replace the valve spring.

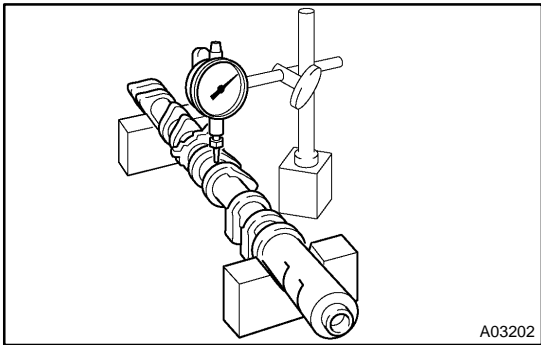

10. INSPECT CAMSHAFT

- (a) Inspect the circle runout.
 (1) Place the camshaft on V-blocks.
 (2) Using a dial indicator, measure the circle runout at the center journal.
Maximum circle runout: 0.08 mm (0.0031 in.)
 If the circle runout is greater than maximum, replace the camshaft.

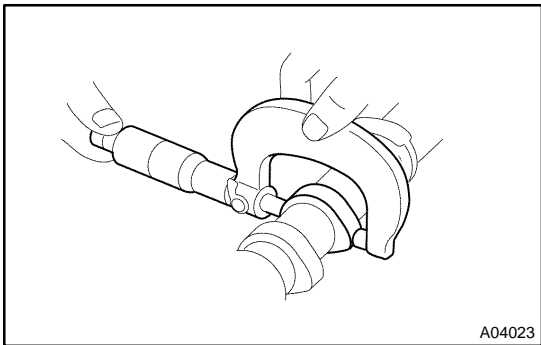

- (b) Using a micrometer, measure the cam lobe height.
Standard cam lobe height:

Intake	42.610 – 42.710 mm (1.6776 – 1.6815 in.)
Exhaust	42.630 – 42.730 mm (1.6783 – 1.6823 in.)

Minimum cam lobe height:

Intake	42.46 mm (1.6717 in.)
Exhaust	42.48 mm (1.6724 in.)

If the cam lobe height is less than minimum, replace the camshaft.

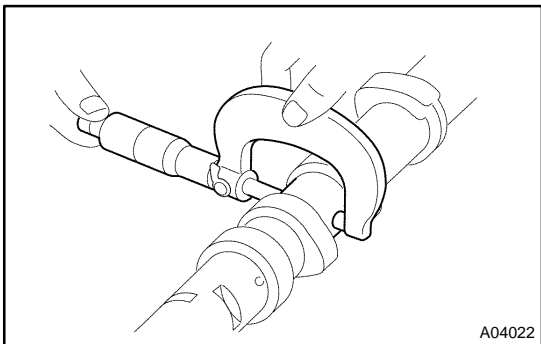

- (c) Inspect the journal.
 (1) Using a micrometer, measure the journal diameter for the camshaft bearing.
Journal diameter:
26.954 – 26.970 mm (1.0612 – 1.0618 in.)
 If the journal diameter is not as specified, check the oil clearance.

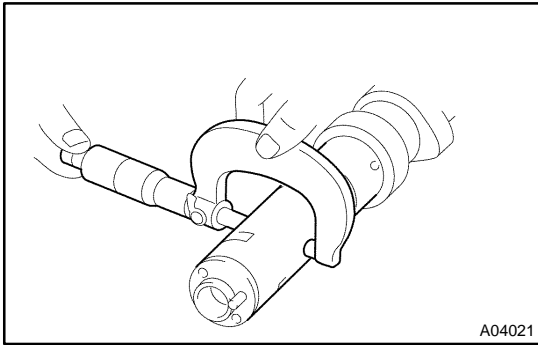

A04021

- (2) Using a micrometer, measure the journal diameter for the camshaft timing tube.

Journal diameter:

30.984 – 31.000 mm (1.2198 – 1.2205 in.)

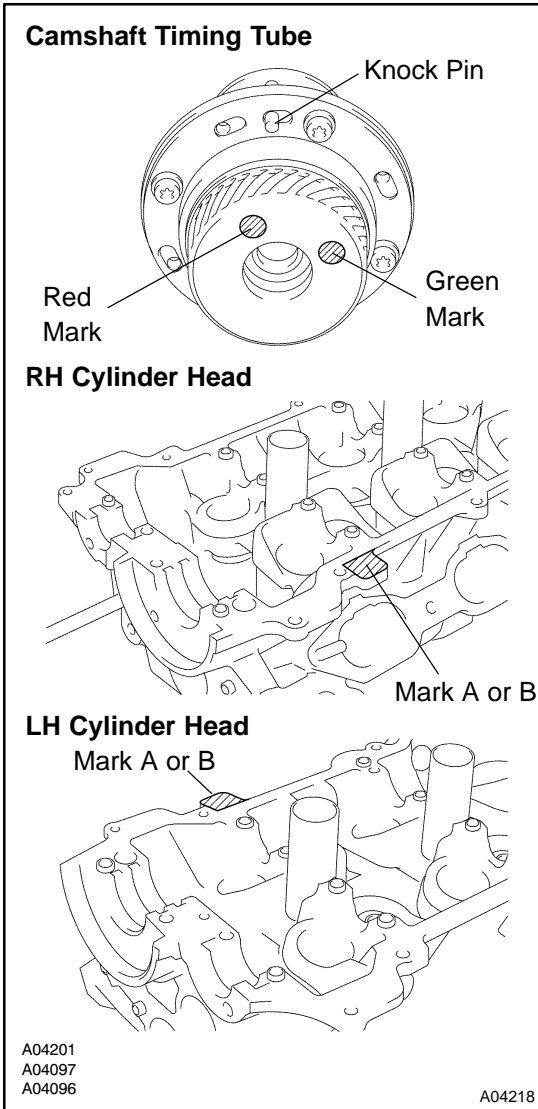

A04201
A04097
A04096

A04218

11. INSPECT CAMSHAFT TIMING TUBE

HINT:

- There are 2 sizes of the camshaft timing tube journal diameter, green and red marks accordingly. The mark is on the face of the camshaft timing tube.
- When replacing the timing tube, select a new timing tube according to the mark on the cylinder head.

Cylinder Head	Camshaft timing tube
Mark A	Green mark
Mark B	Red mark

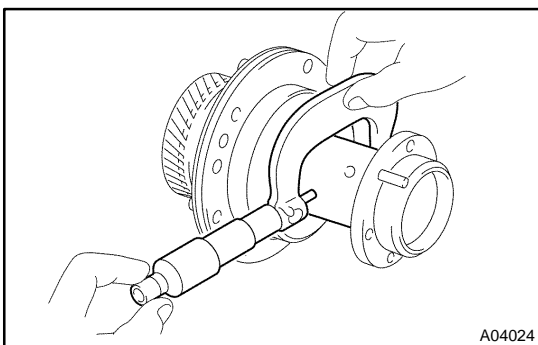

A04024

- (a) Using a micrometer, measure the journal diameter.

Journal diameter:

Green mark	39.958 – 39.964 mm (1.5731 – 1.5734 in.)
Red mark	39.964 – 39.970 mm (1.5734 – 1.5736 in.)

If the journal diameter is not as specified, check the oil clearance.

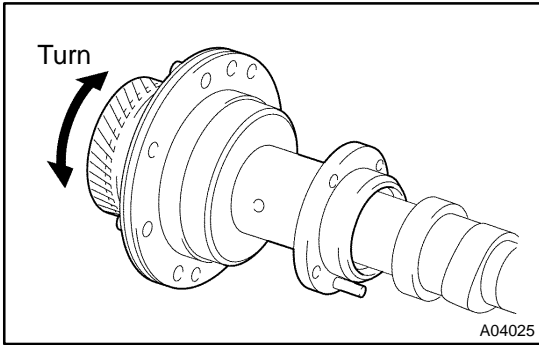

- (b) Install the timing tube to the intake camshaft, and check the timing tube turn smoothly. If necessary, replace the timing tube and intake camshaft.

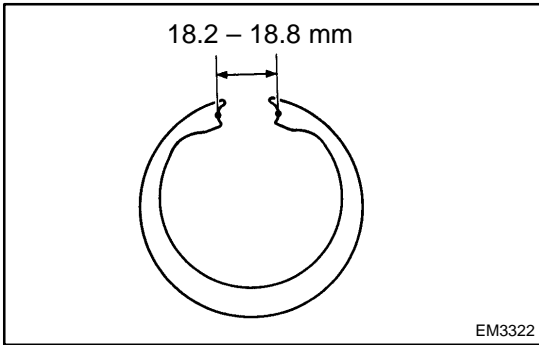

12. INSPECT CAMSHAFT GEAR SPRING

Using vernier calipers, measure the free distance between the spring ends.

Free distance: 18.2 - 18.8 mm (0.712 - 0.740 in.)

If the free distance is not as specified, replace the gear spring.

13. INSPECT CAMSHAFT BEARINGS

Check that bearings for flaking and scoring.

If the bearings are damaged, replace the bearing caps and cylinder head as a set.

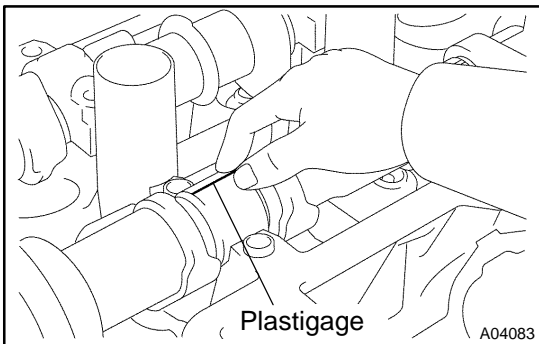

14. INSPECT CAMSHAFT AND CAMSHAFT TIMING TUBE JOURNAL OIL CLEARANCE

- (a) Install the camshaft timing tube to the intake camshaft. (See page EM-61)
- (b) Clean the bearing caps and journals.
- (c) Place the camshafts on the cylinder head.
- (d) Lay a strip of Plastigage across each of the journals.

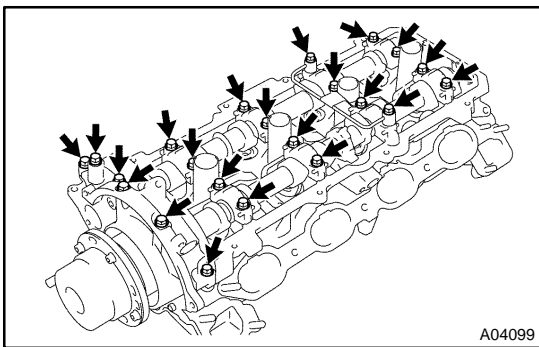

- (e) Install the bearing caps. (See page EM-61)

NOTICE:

Do not turn the camshaft.

- (f) Remove the bearing caps.

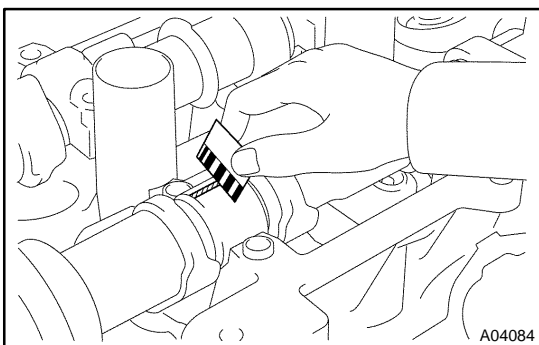

- (g) Measure the Plastigage at its widest point.

Standard oil clearance:

Camshaft journal	0.030 - 0.067 mm (0.0012 - 0.0026 in.)
Camshaft timing tube journal	
Green mark	0.036 - 0.050 mm (0.0014 - 0.0020 in.)
Red mark	0.038 - 0.052 mm (0.0015 - 0.0020 in.)

Maximum oil clearance:

Camshaft journal	0.100 mm (0.0039 in.)
Camshaft timing tube journal	0.085 mm (0.0033 in.)

If the oil clearance is greater than maximum, replace the camshaft. If necessary, replace the bearing caps and cylinder head as a set.

- (h) Completely remove the Plastigage.
- (i) Remove the camshafts.
- (j) Remove the camshaft timing tube from the intake camshaft.

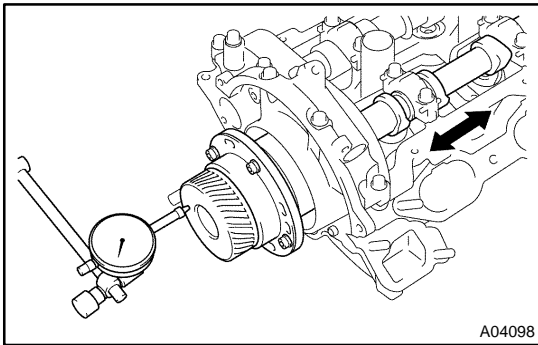
**15. INSPECT CAMSHAFT THRUST CLEARANCE**

- (a) Install the camshaft timing tube to the intake camshaft. (See page EM-61)
- (b) Install the camshaft. (See page EM-61)
- (c) Using a dial indicator, measure the thrust clearance while moving the camshaft back and forth.

Standard thrust clearance:

Intake	0.060 – 0.100 mm (0.0024 – 0.0039 in.)
Exhaust	0.040 – 0.090 mm (0.0016 – 0.0035 in.)

Maximum thrust clearance:

Intake	0.13 mm (0.0051 in.)
Exhaust	0.12 mm (0.0047 in.)

If the thrust clearance is greater than maximum, replace the camshaft. If necessary, replace the bearing caps and cylinder head as a set.

- (d) Remove the camshafts.
- (e) Remove the camshaft timing tube from the intake camshaft.

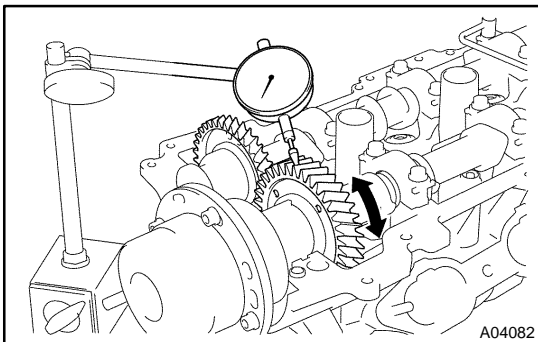
**16. INSPECT CAMSHAFT GEAR BACKLASH**

- (a) Install the drive gear to the camshaft timing tube. (See page EM-61)
- (b) Install the camshaft timing tube to the intake camshaft. (See page EM-61)
- (c) Install the camshafts without installing the exhaust camshaft sub-gear and front bearing cap. (See page EM-61)

- (d) Using a dial indicator, measure the backlash.

Standard backlash:

0.020 – 0.200 mm (0.0008 – 0.0079 in.)

Maximum backlash: 0.30 mm (0.0188 in.)

If the backlash is greater than maximum, replace the Intake camshaft drive gear and exhaust camshaft.

- (e) Remove the camshafts.
 (f) Remove the camshaft timing tube from the intake camshaft.
 (g) Remove the drive gear from the camshaft timing tube.

17. INSPECT VALVE LIFTERS AND LIFTER BORES

- (a) Using a caliper gauge, measure the lifter bore diameter of the cylinder head.

Lifter bore diameter:

31.000 – 31.016 mm (1.2205 – 1.2211 in.)

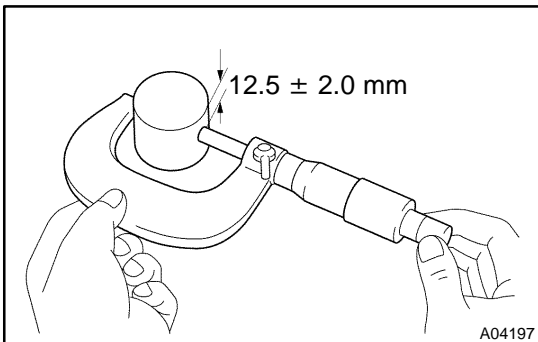
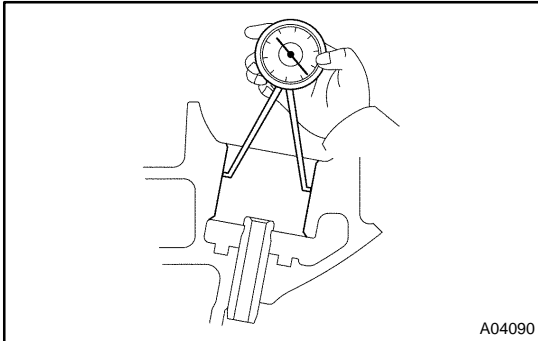

- (b) Using a micrometer, measure the lifter diameter at the 12.5 ± 2.0 mm (0.492 ± 0.079 in.) from the top surface.

Lifter diameter:

30.966 – 30.976 mm (1.2191 – 1.2195 in.)

- (c) Subtract the lifter diameter measurement from the lifter bore diameter measurement.

Standard oil clearance:

0.024 – 0.050 mm (0.0009 – 0.0020 in.)

Maximum oil clearance: 0.07 mm (0.0028 in.)

If the oil clearance is greater than maximum, replace the lifter. If necessary, replace the cylinder head.

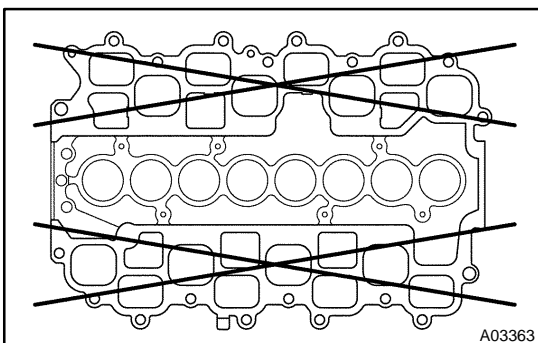

18. INSPECT UPPER INTAKE MANIFOLD

Using a precision straight edge and feeler gauge, measure the surface contacting the lower intake manifold for warpage.

Maximum warpage: 0.15 mm (0.0059 in.)

If warpage is greater than maximum, replace the upper intake manifold.

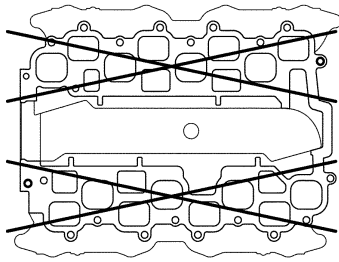
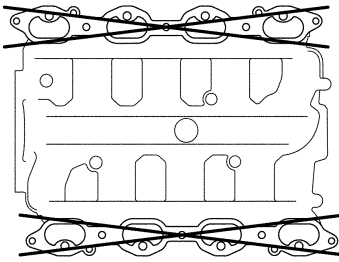
Upper Intake Manifold Side**Cylinder Head Side**A03365
A03364

A04239

19. INSPECT LOWER INTAKE MANIFOLD

Using a precision straight edge and feeler gauge, measure the surface contacting the cylinder head and upper intake manifold for warpage.

Maximum warpage: 0.15 mm (0.0059 in.)

If warpage is greater than maximum, replace the lower intake manifold.

20. INSPECT EXHAUST MANIFOLD

Using a precision straight edge and feeler gauge, measure the surface contacting the cylinder head for warpage.

Maximum warpage: 0.50 mm (0.0197 in.)

If warpage is greater than maximum, replace the manifold.

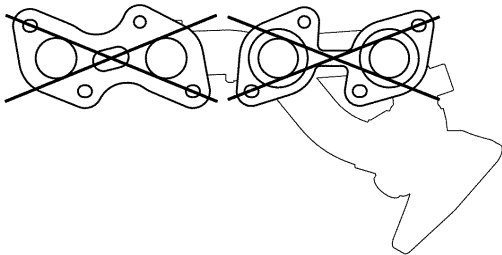

A04109