

Navigation, Parking Assist (Rear View Monitor) and Audio System

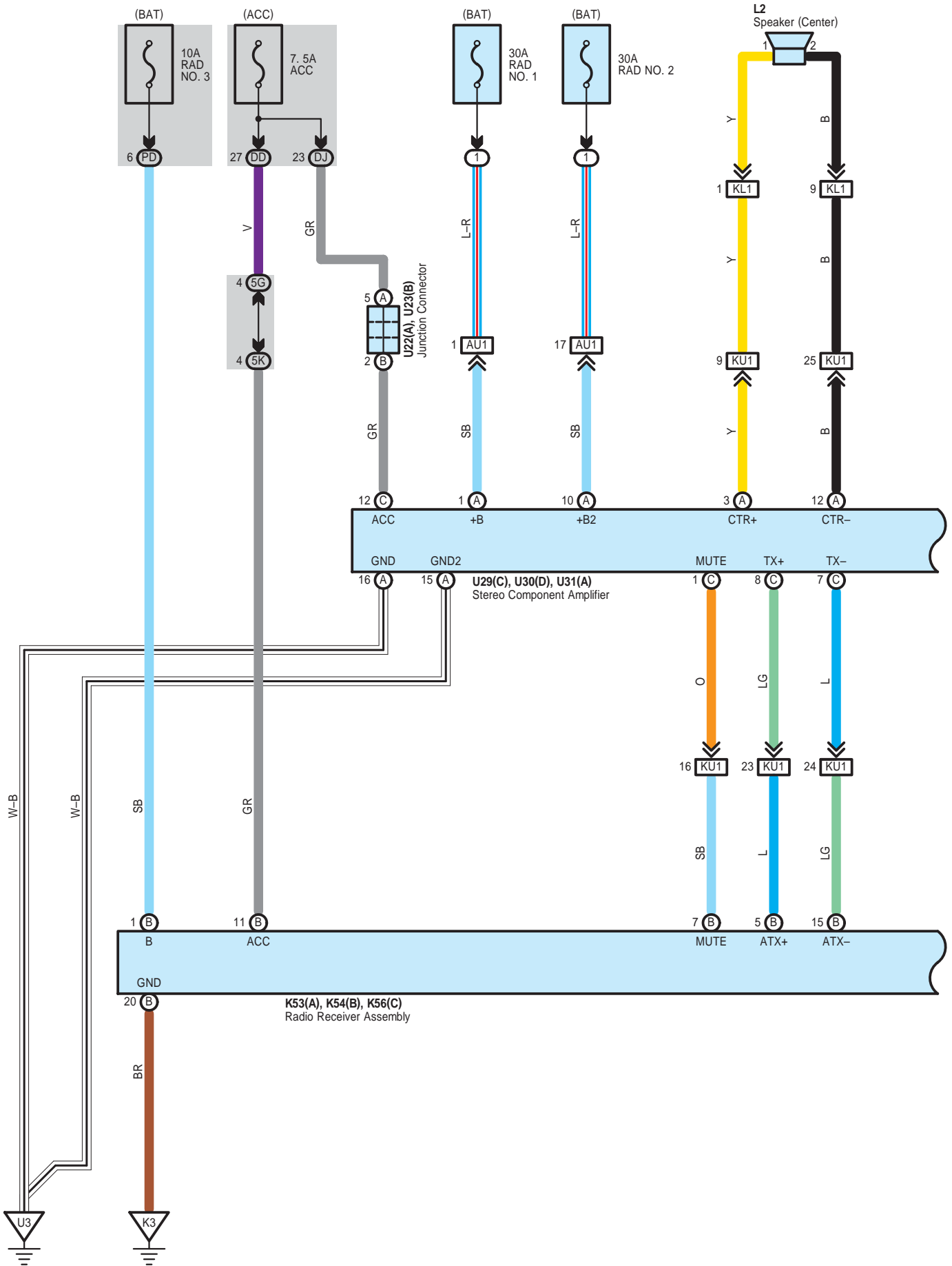

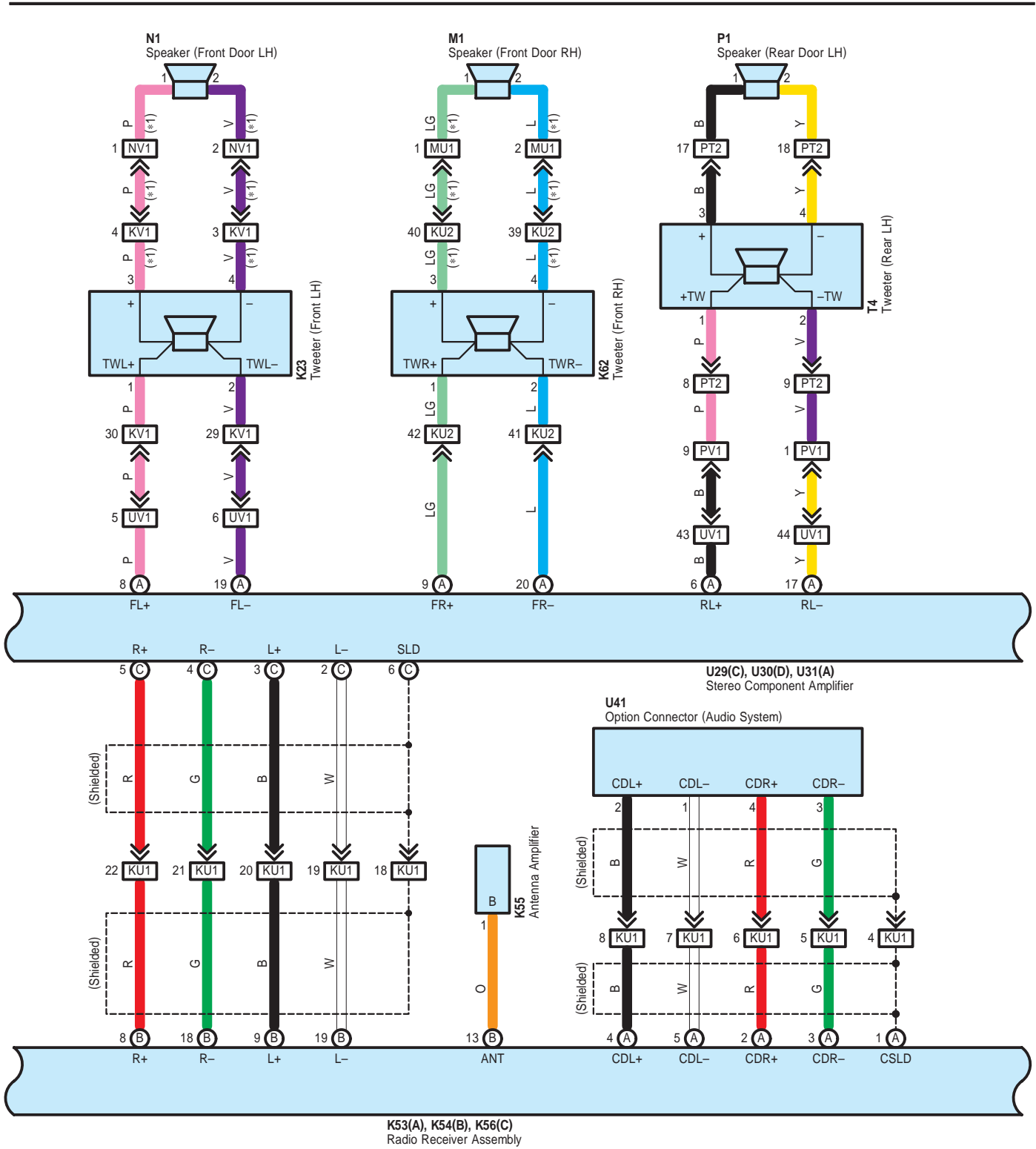

* 1 : Except MARK LEVINSON

Navigation, Parking Assist (Rear View Monitor) and Audio System

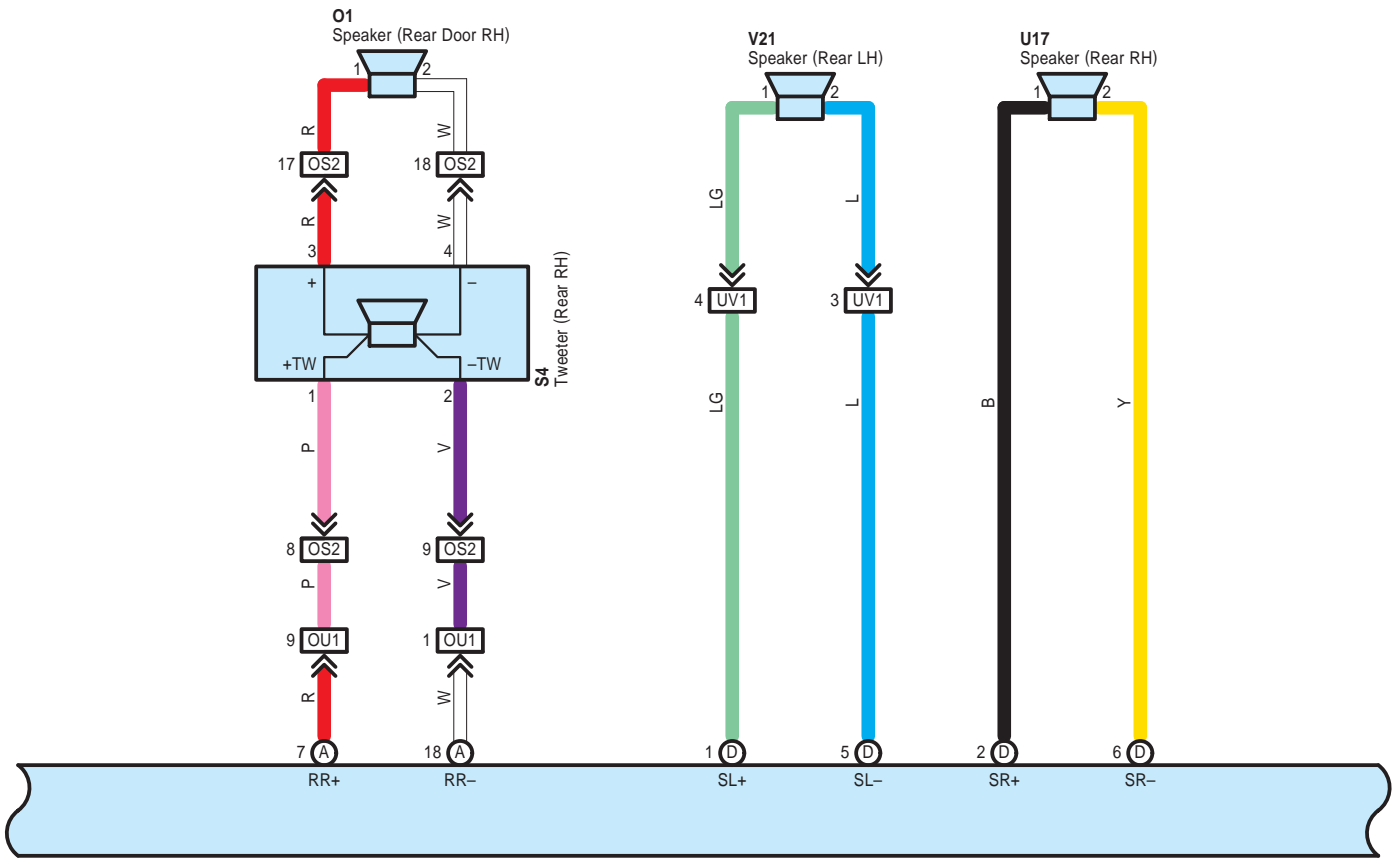

U29(C), U30(D), U31(A)
Stereo Component Amplifier

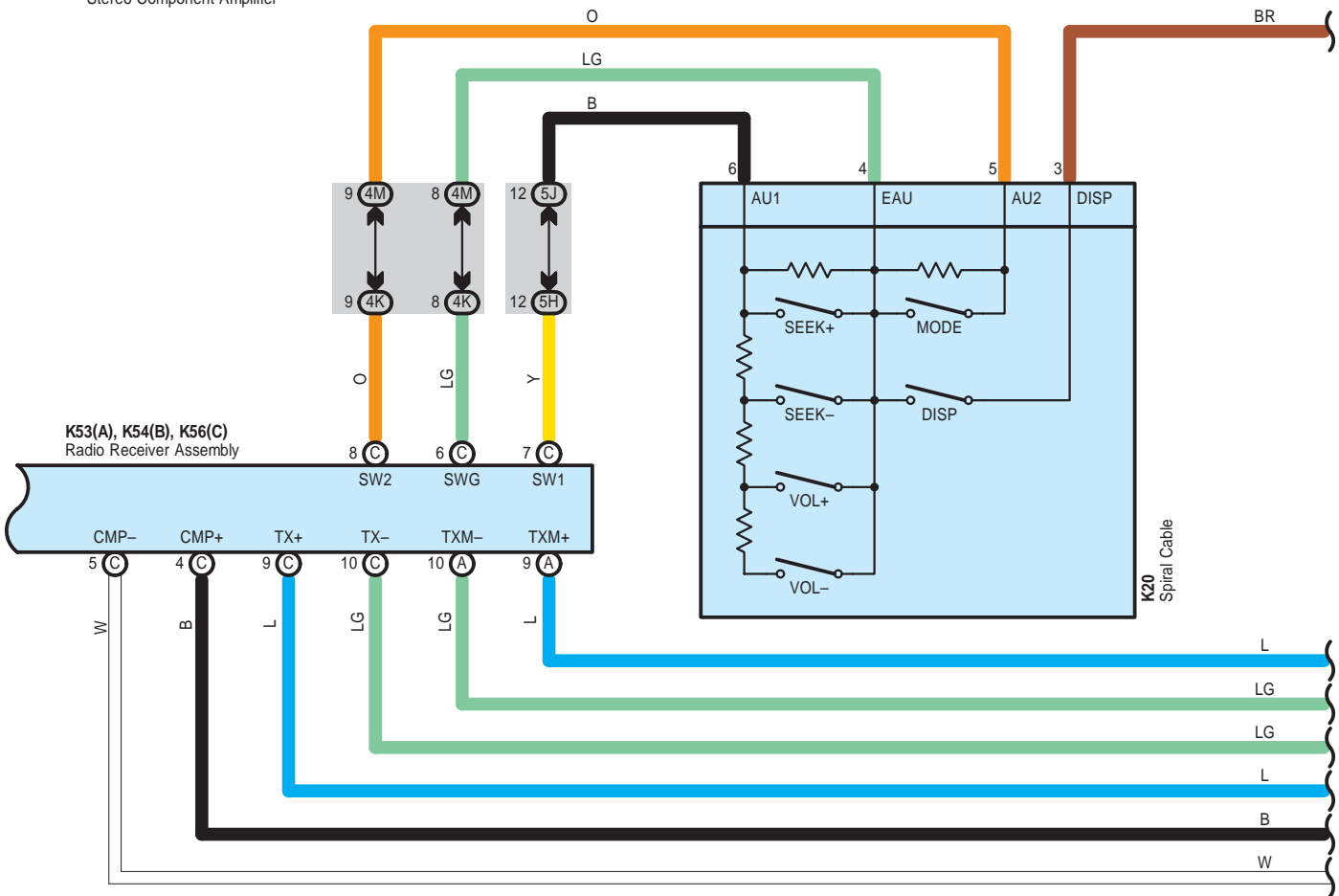

K53(A), K54(B), K56(C)
Radio Receiver Assembly

K20
Spiral Cable

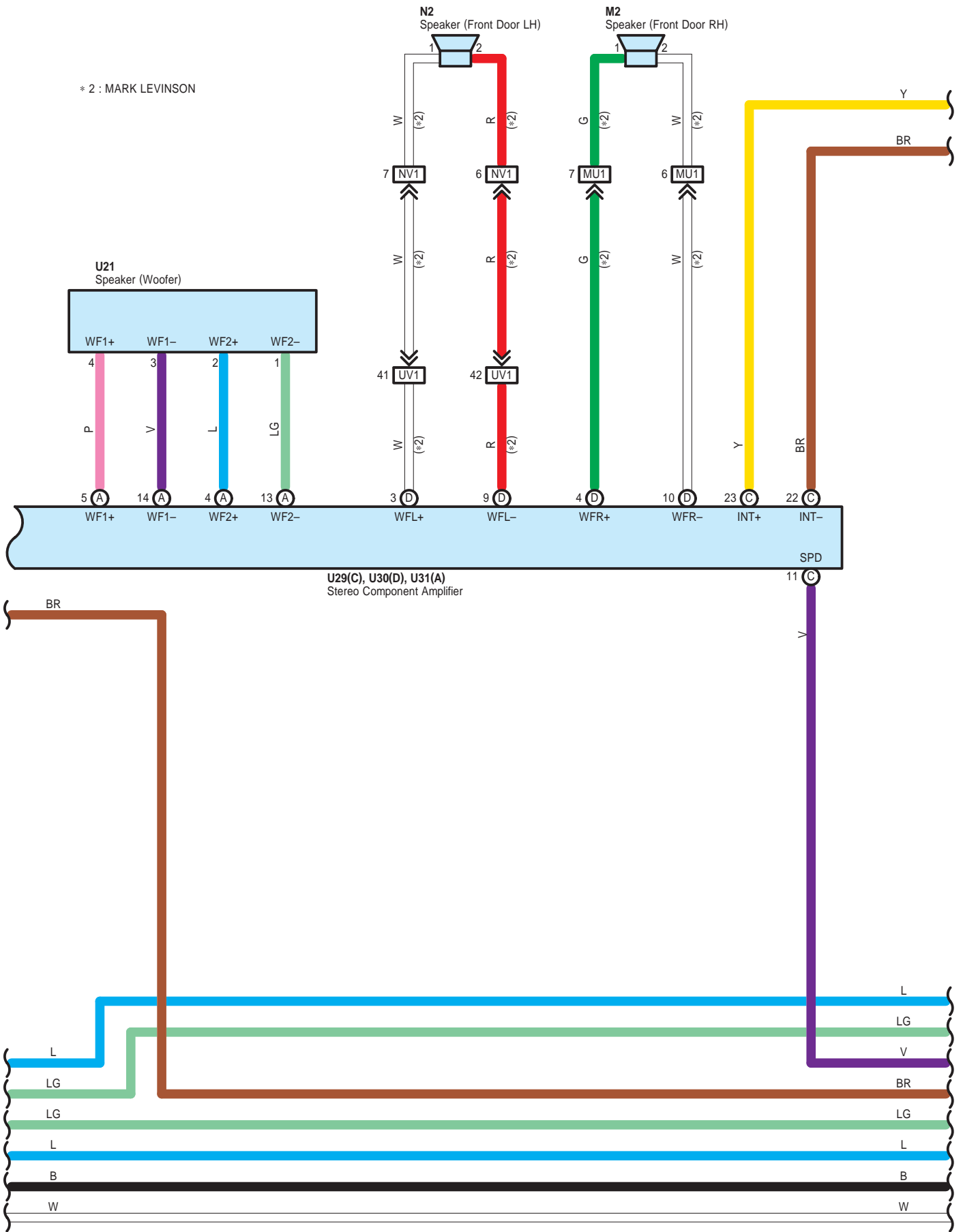

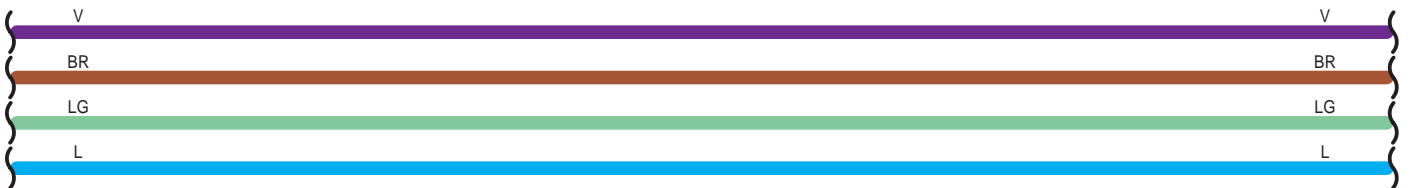
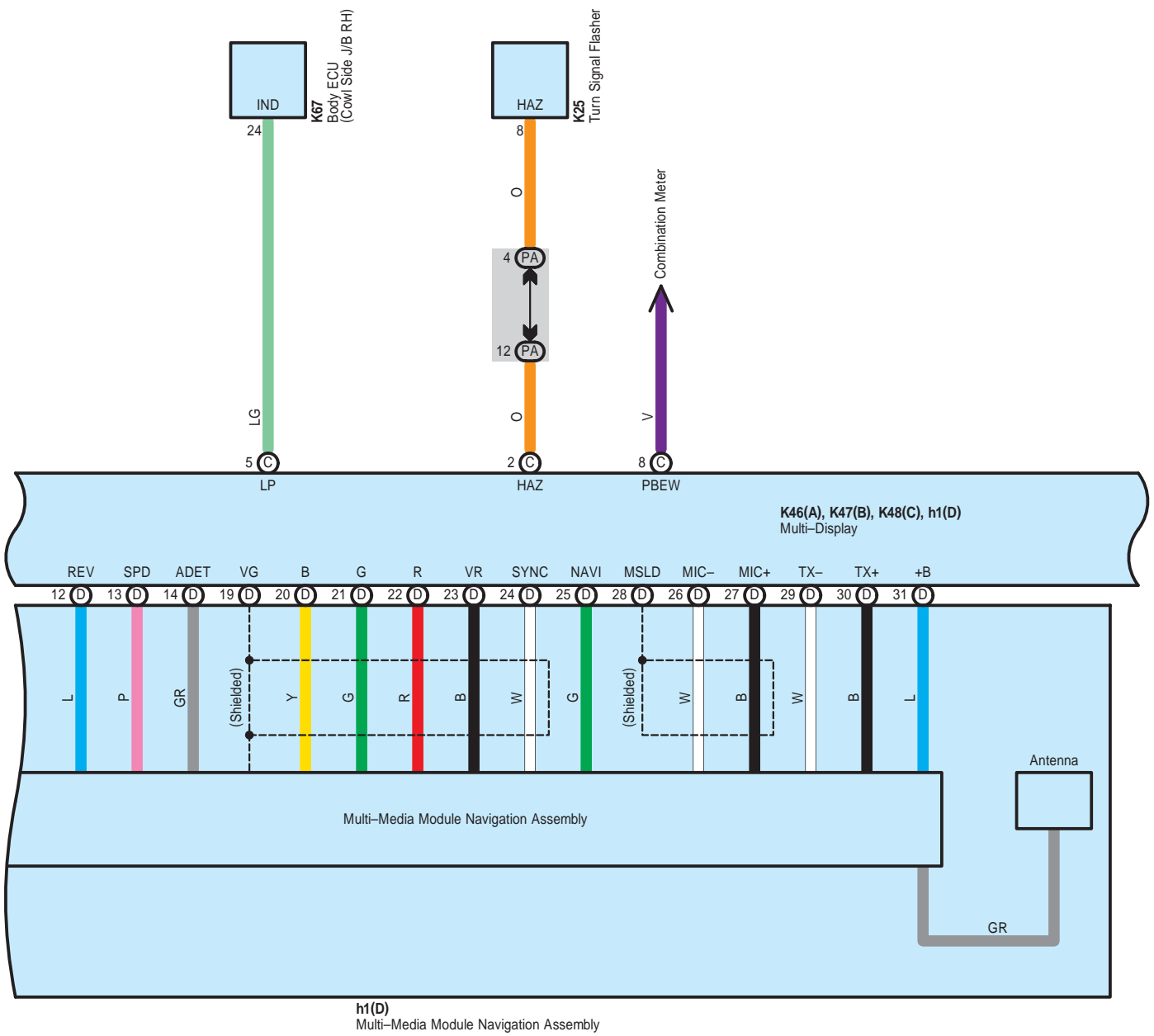

Navigation, Parking Assist (Rear View Monitor) and Audio System

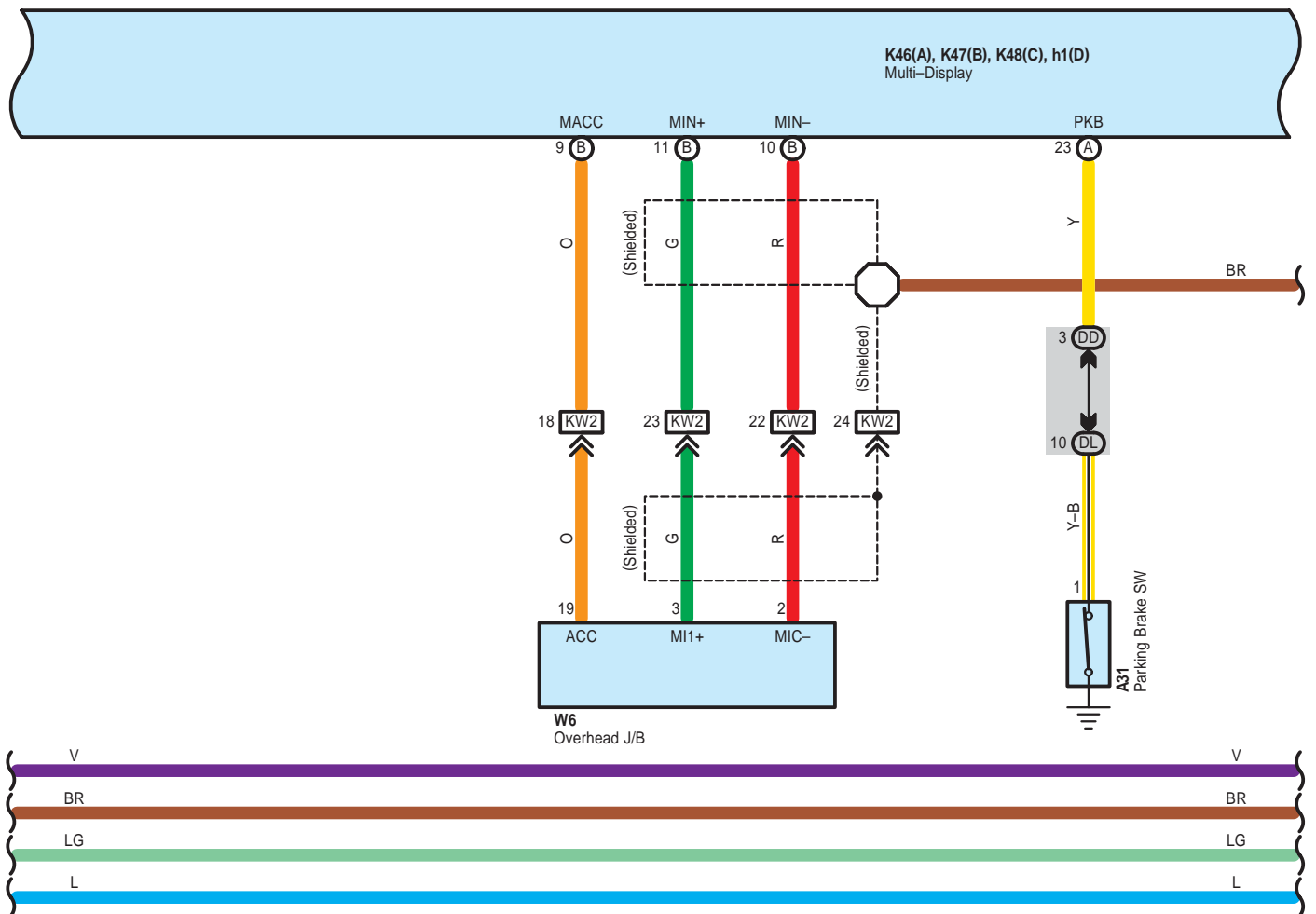

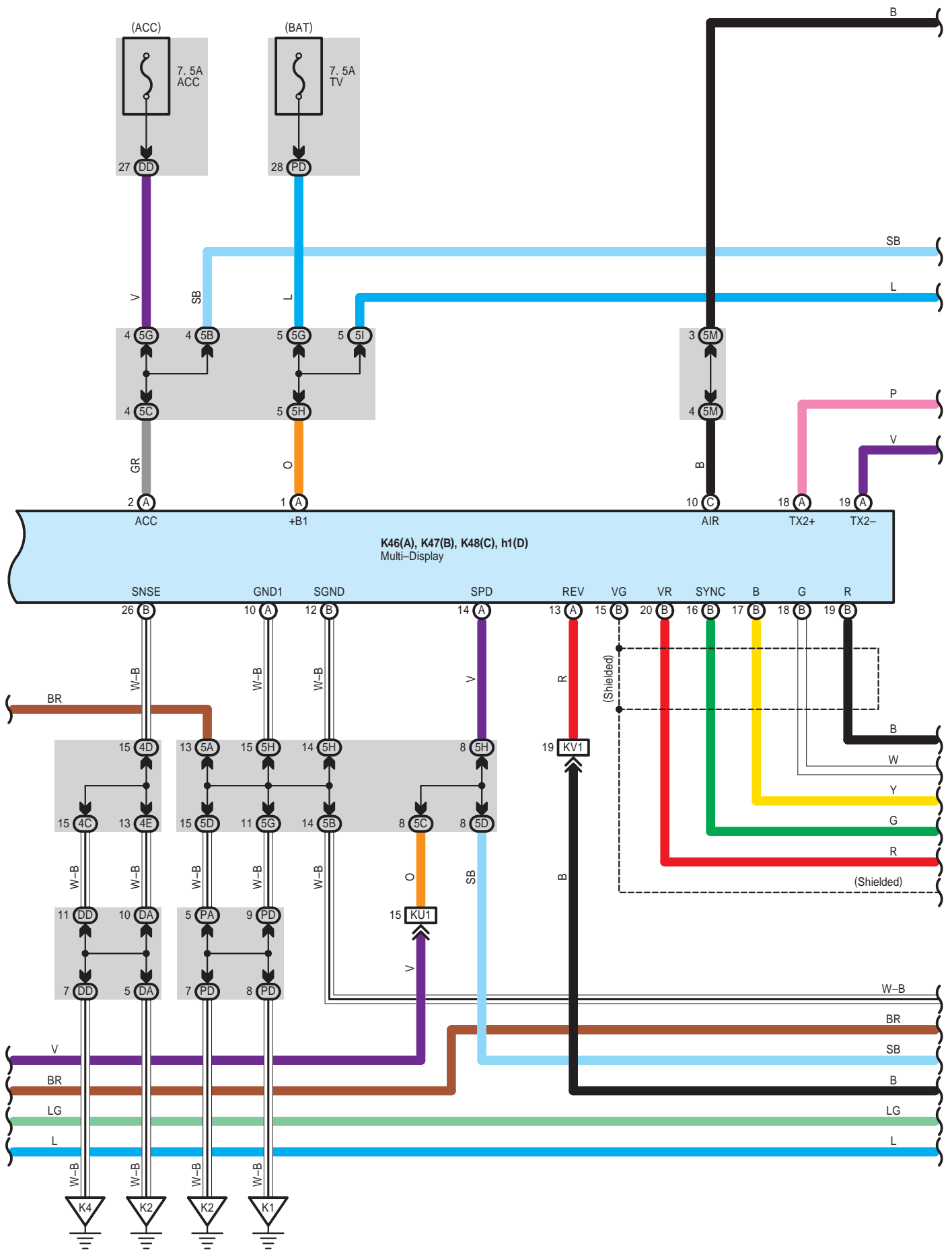

Navigation, Parking Assist (Rear View Monitor) and Audio System

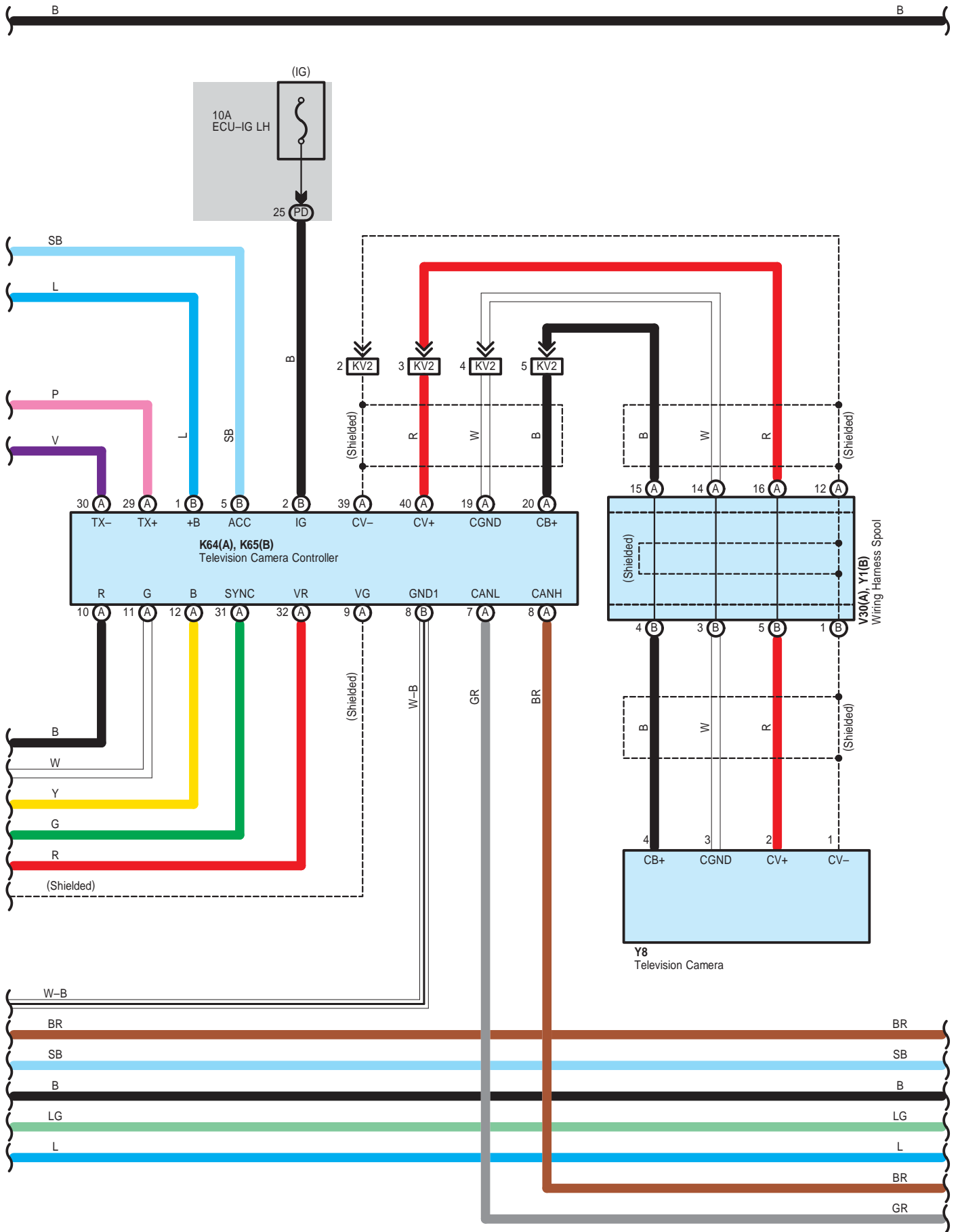

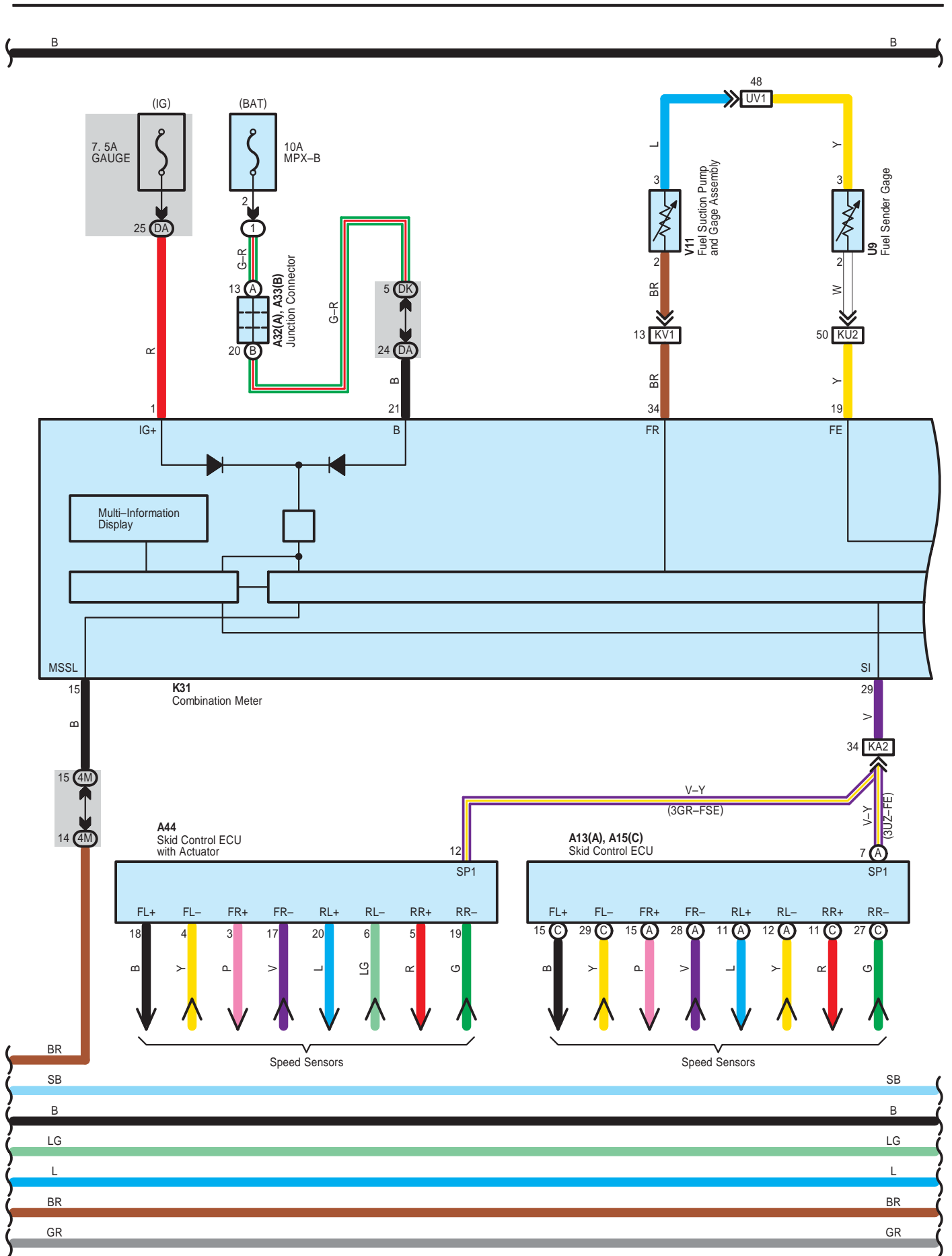

Navigation, Parking Assist (Rear View Monitor) and Audio System

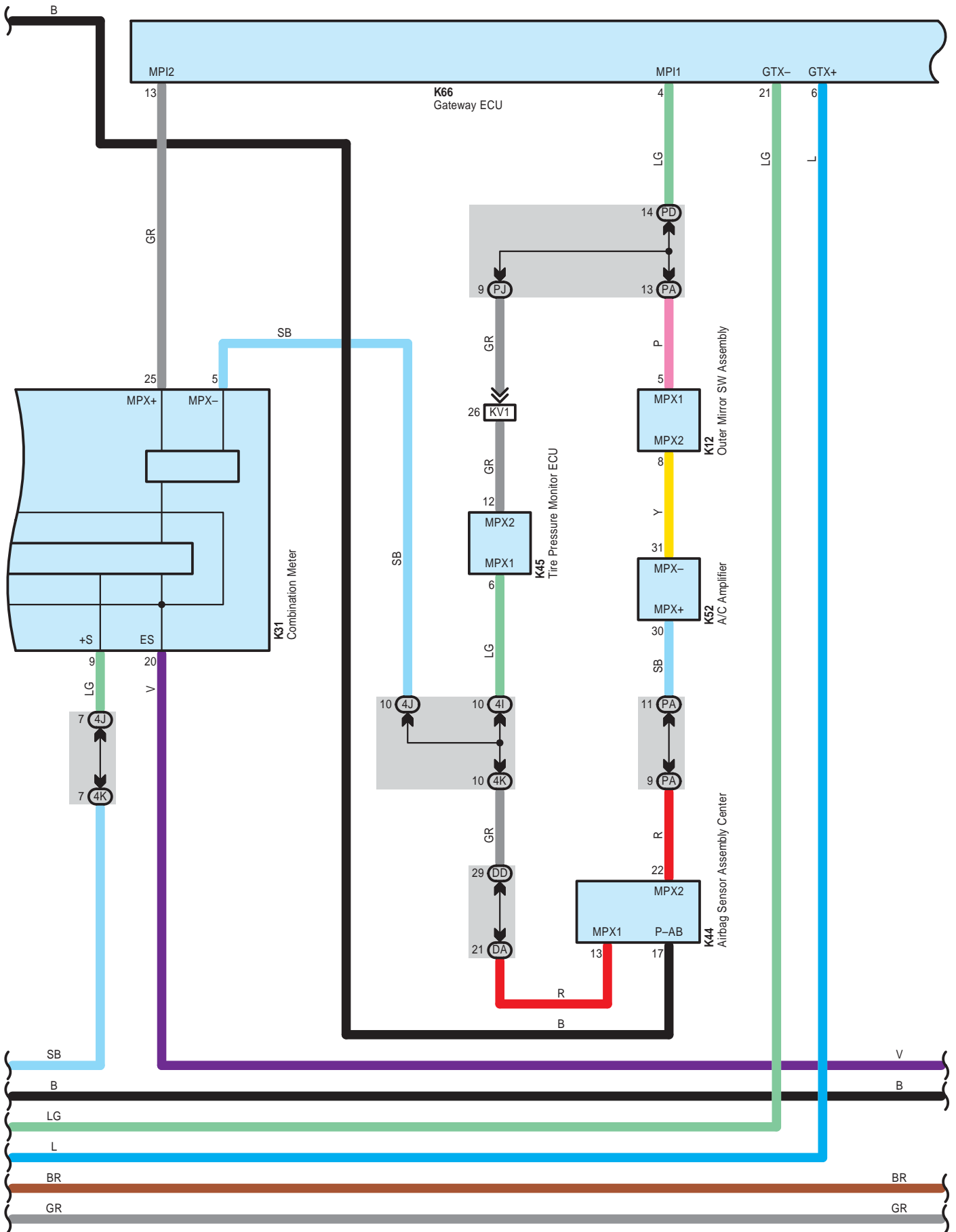

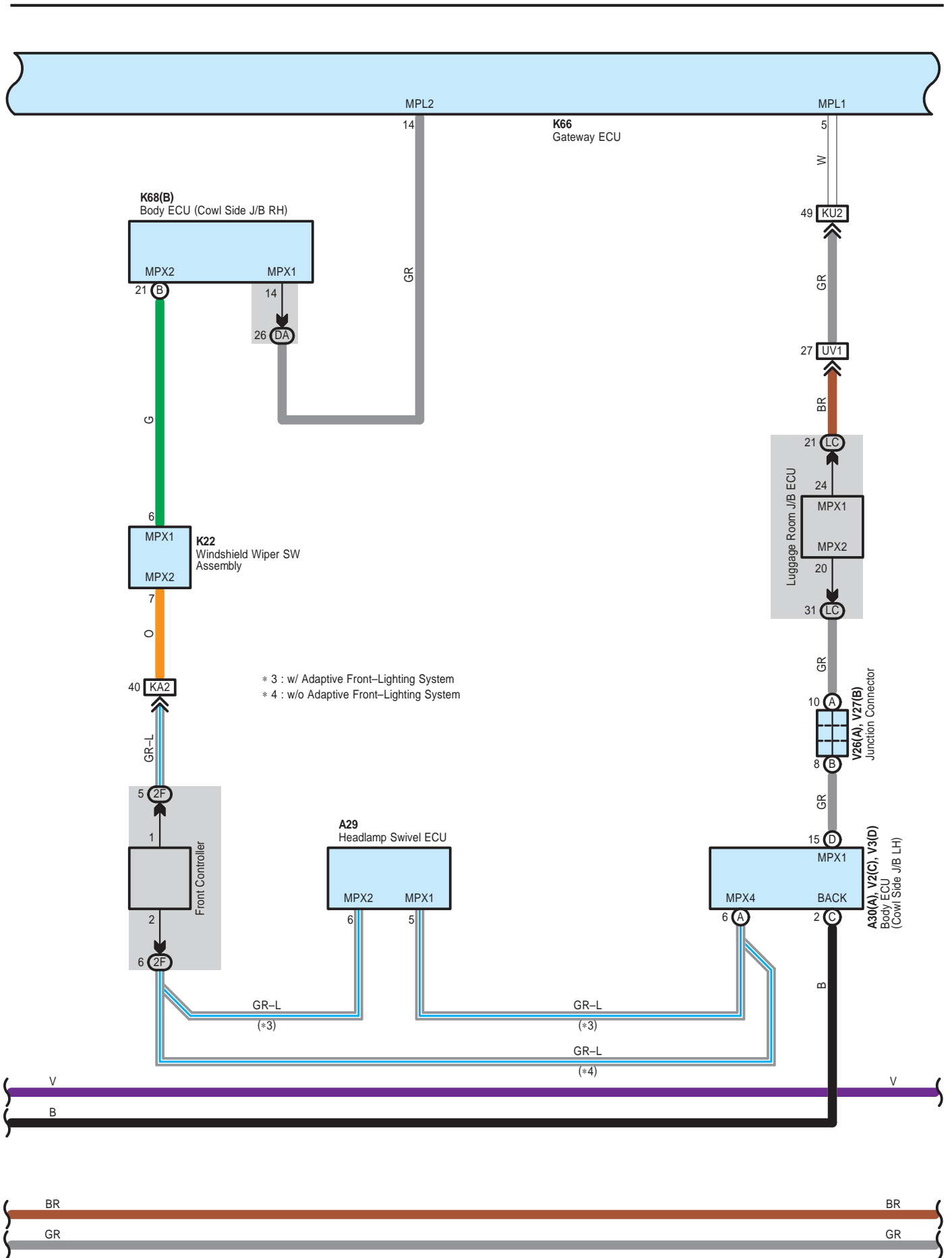

Navigation, Parking Assist (Rear View Monitor) and Audio System

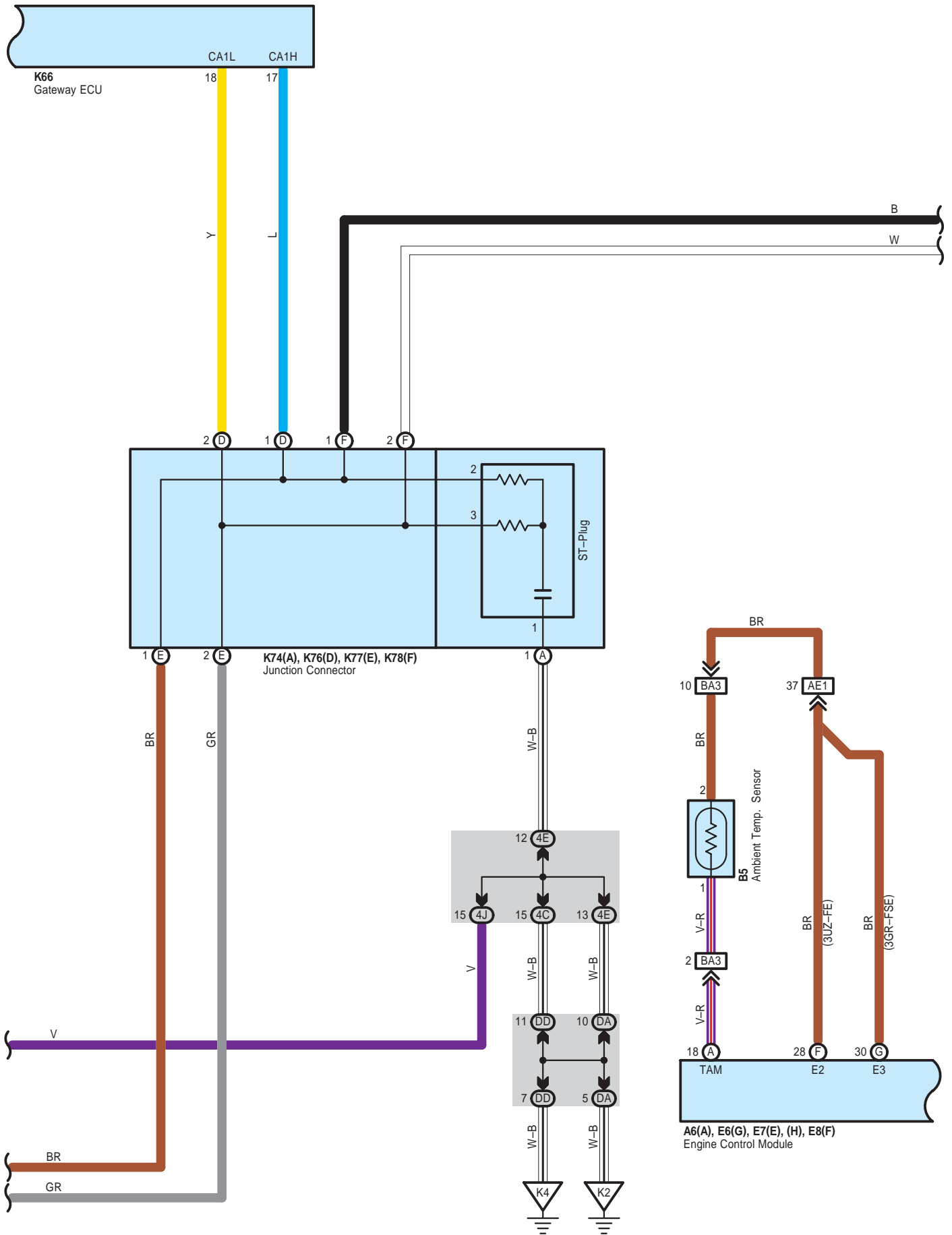

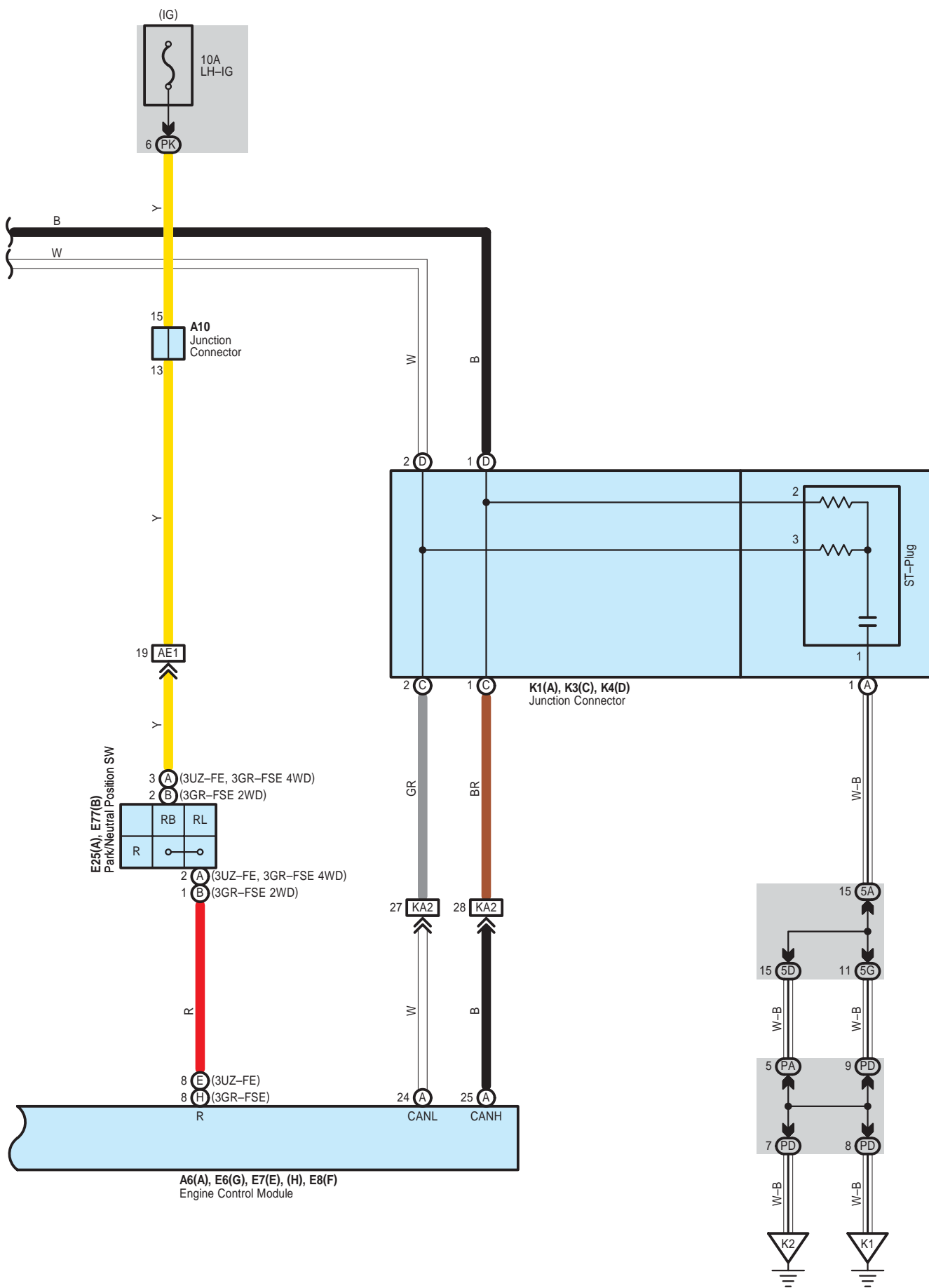

Navigation, Parking Assist (Rear View Monitor) and Audio System

○ : Parts Location

Code		See Page	Code		See Page	Code		See Page
A6	A	64 (3UZ-FE)	K22		73	N1		76
		68 (3GR-FSE)	K23		73	N2		76
A10		64 (3UZ-FE)	K25		73	O1		76
		68 (3GR-FSE)	K31		73	P1		76
A13	A	64 (3UZ-FE)	K44		74	S4		77
A15	C	64 (3UZ-FE)	K45		74	T4		77
A29		72	K46	A	74	U9		78
A30	A	72	K47	B	74	U17		78
A31		72	K48	C	74	U21		78
A32	A	72	K52		74	U22	A	78
A33	B	72	K53	A	74	U23	B	78
A44		68 (3GR-FSE)	K54	B	74	U29	C	78
B5		65 (3UZ-FE)	K55		74	U30	D	78
		69 (3GR-FSE)	K56	C	74	U31	A	78
E6	G	70 (3GR-FSE)	K62		74	U41		78
E7	E	66 (3UZ-FE)	K64	A	74	V2	C	75
	H	70 (3GR-FSE)	K65	B	74	V3	D	75
E8	F	66 (3UZ-FE)	K66		74	V11		79
E25	A	66 (3UZ-FE)	K67		74	V21		79
		70 (3GR-FSE)	K68	B	74	V26	A	79
E77	B	70 (3GR-FSE)	K74	A	62, 74	V27	B	79
K1	A	60, 73	K76	D	62, 74	V30	A	79
K3	C	60, 73	K77	E	62, 74	W6		80
K4	D	60, 73	K78	F	62, 74	Y1	B	80
K12		73	L2		75	Y8		80
K16		73	M1		76	h1	D	75
K20		73	M2		76			

○ : Relay Blocks

Code	See Page	Relay Blocks (Relay Block Location)
1	22	Engine Room R/B No.1 (Near the Battery)

 : Junction Block and Wire Harness Connector

Code	See Page	Junction Block and Wire Harness (Connector Location)
2F	27	Engine Room Main Wire and Engine Room R/B No.2 (Engine Compartment Left)
4C	50	Instrument Panel Wire and Center J/B RH (Upper the Glove Box)
4D		
4E		
4I		
4J		
4K		
4M		
5A	46	Instrument Panel Wire and Center J/B LH (Upper the Glove Box)
5B		
5C		
5D		
5G		
5H		
5I		
5J		
5K		
5M		
DA	41	Instrument Panel Wire and Cowl Side J/B RH (Cowl Side Right)
DD		
DJ	42	Floor Wire and Cowl Side J/B RH (Cowl Side Right)
DK	42	Engine Room Main Wire and Cowl Side J/B RH (Cowl Side Right)
DL		
LC	57	Floor No.2 Wire and Luggage Room J/B (Luggage Room Left)
PA	35	Instrument Panel Wire and Cowl Side J/B LH (Cowl Side Left)
PD		
PJ	36	Floor No.2 Wire and Cowl Side J/B LH (Cowl Side Left)
PK	36	Engine Room Main Wire and Cowl Side J/B LH (Cowl Side Left)

 : Connector Joining Wire Harness and Wire Harness

Code	See Page	Joining Wire Harness and Wire Harness (Connector Location)
AE1	84 (3UZ-FE)	Engine Room Main Wire and Engine Wire (Inside of the ECU Box)
	85 (3GR-FSE)	
AU1	86	Engine Room Main Wire and Floor No.1 Wire (Cowl Side Panel RH)
BA3	84 (3UZ-FE)	Engine Room No.2 Wire and Engine Room Main Wire (Inside of the Engine Room R/B No.2)
	85 (3GR-FSE)	
KA2	86	Instrument Panel Wire and Engine Room Main Wire (Left Kick Panel)
KL1	86	Instrument Panel Wire and Instrument Panel No.2 Wire (Center of the Instrument Panel)
KU1	86	Instrument Panel Wire and Floor No.1 Wire (Under the Console Box)
KU2	86	Instrument Panel Wire and Floor No.1 Wire (Right Kick Panel)
KV1	86	Instrument Panel Wire and Floor No.2 Wire (Left Kick Panel)
KV2	86	Instrument Panel Wire and Floor No.2 Wire (Under the Console Box)
KW2	86	Instrument Panel Wire and Roof Wire (Left Side of the Instrument Panel)
MU1	86	Front Door RH Wire and Floor No.1 Wire (Right Kick Panel)
NV1	86	Front Door LH Wire and Floor No.2 Wire (Left Kick Panel)
OS2	87	Rear Door No.1 Wire and Rear Door RH Wire (Front Door Inner Panel RH)
OU1	87	Rear Door No.1 Wire and Floor No.1 Wire (Right Center Pillar)
PT2	87	Rear Door No.2 Wire and Rear Door LH Wire (Rear Door Inner Panel LH)
PV1	87	Rear Door No.2 Wire and Floor No.2 Wire (Left Center Pillar)
UV1	87	Floor No.1 Wire and Floor No.2 Wire (Center of the Rear Floor Partition Panel)

Navigation, Parking Assist (Rear View Monitor) and Audio System



: Ground Points

Code	See Page	Ground Points Location
K1	86	Left Kick Panel
K2	86	Left Side of the Shift Lever
K3	86	Right Side of the Shift Lever
K4	86	Right Kick Panel
U3	87	Roof Side Rear Inner Panel RH

