

- b. Disconnect the connectors, detach the clamp and remove the combination meter assembly.

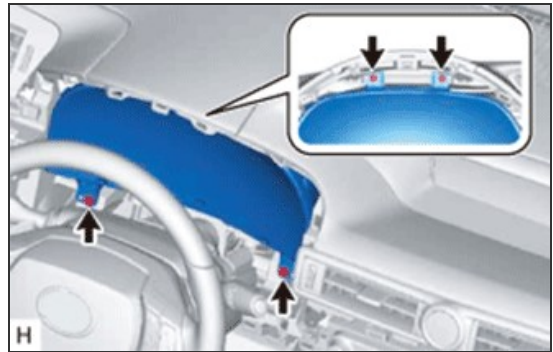

21. REMOVE NO. 1 INSTRUMENT PANEL REGISTER ASSEMBLY

- a. Put protective tape around the No. 1 instrument panel register assembly.

Text in Illustration

*1	Protective Tape
----	-----------------

- b. Using a moulding remover, detach the 4 clips.
- c. Disconnect the connector and remove the No. 1 instrument panel register assembly.

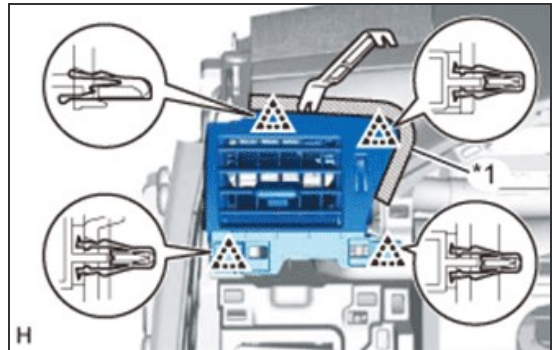

22. REMOVE INSTRUMENT SIDE PANEL RH

- a. Put protective tape around the instrument side panel RH.

Text in Illustration

*1	Protective Tape
----	-----------------

- b. Using a moulding remover, detach the 7 clips and remove the instrument side panel RH.
- c. w/ Airbag Cut Off Switch:
 - i. Disconnect the connector.

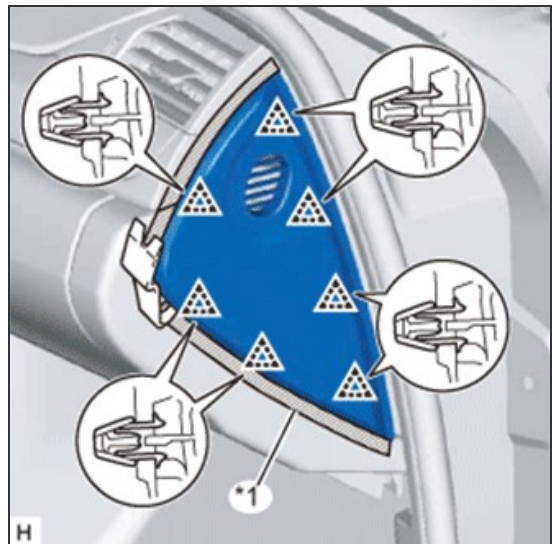

23. REMOVE NO. 2 INSTRUMENT PANEL UNDER COVER SUB-ASSEMBLY

- a. Detach the 5 clips and 2 guides.
- b. Disconnect the connectors, detach the clamp and remove the No. 2 instrument panel under cover sub-assembly.

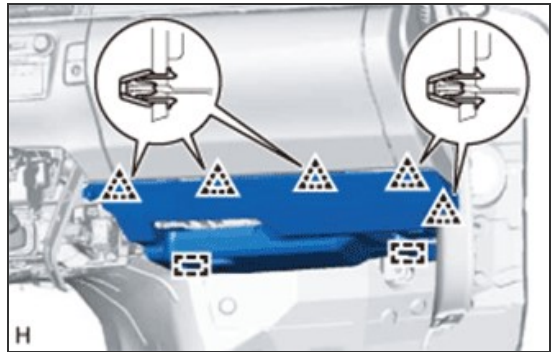

24. REMOVE GLOVE COMPARTMENT DOOR ASSEMBLY

- a. Remove the 3 screws <A> and 2 bolts <E>.

Text in Illustration

*1	Screw <A>
*2	Bolt <E>

- b. Detach the 6 clips.
- c. Disconnect the connectors, detach the clamp and remove the glove compartment door assembly.

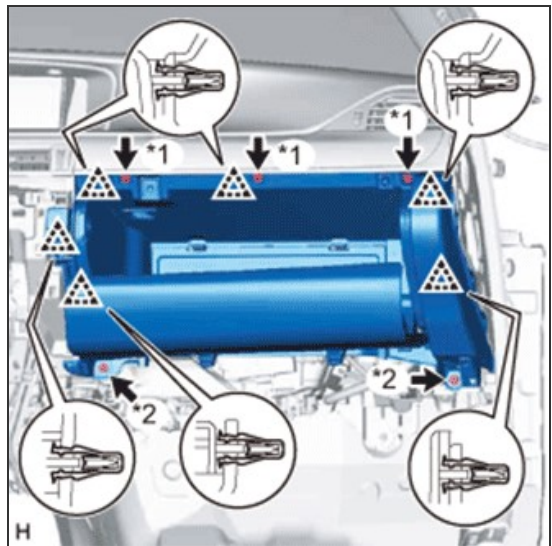

25. REMOVE MULTI-MEDIA MODULE RECEIVER ASSEMBLY

- a. Remove the 2 bolts.

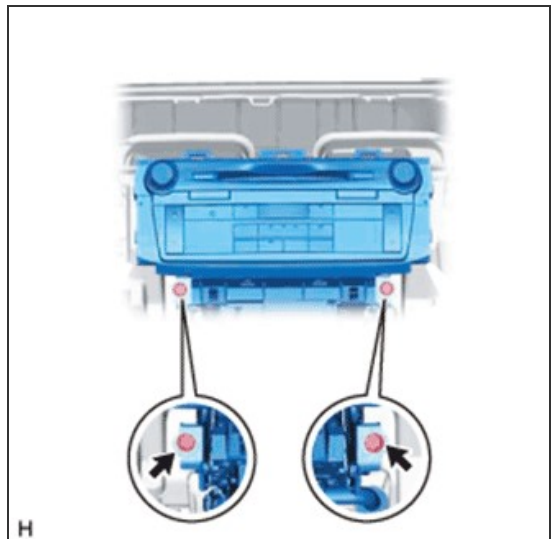

- b. Detach the 2 claws and 2 clips.

- c. Pull out the multi-media module receiver assembly.
- d. Disconnect the connectors and remove the multi-media module receiver assembly.

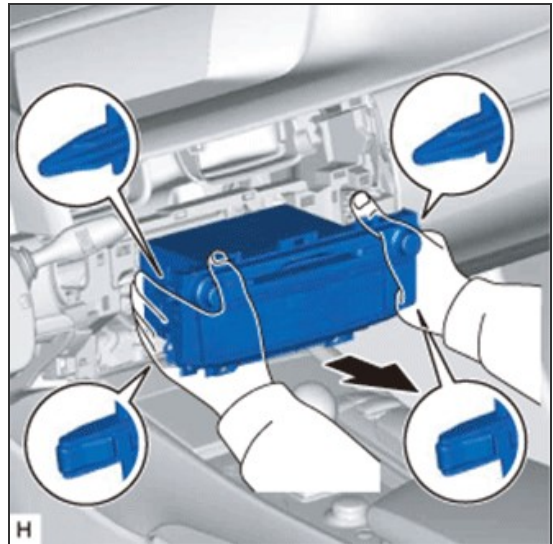

26. REMOVE NO. 2 INSTRUMENT PANEL REGISTER ASSEMBLY

- a. Put protective tape around the No. 2 instrument panel register assembly.

Text in Illustration

*1 Protective Tape

- b. Using a moulding remover, detach the 7 clips.
- c. Disconnect the connectors and remove the No. 2 instrument panel register assembly.

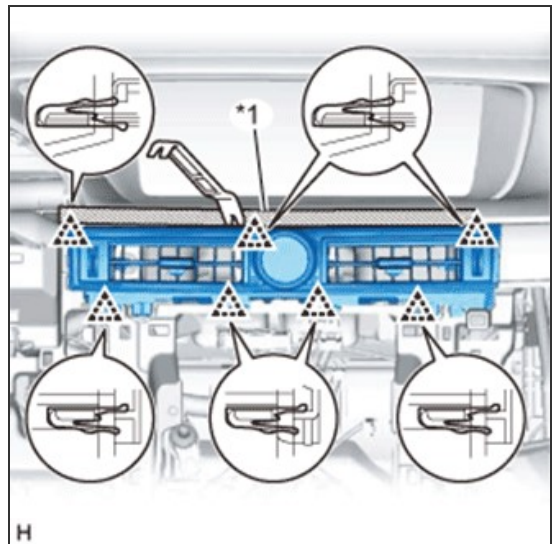

27. REMOVE TELEMATICS TRANSCEIVER (w/ Telematics Transceiver)

- a. Remove the 3 bolts and telematics transceiver with bracket.
- b. Disconnect the connectors.

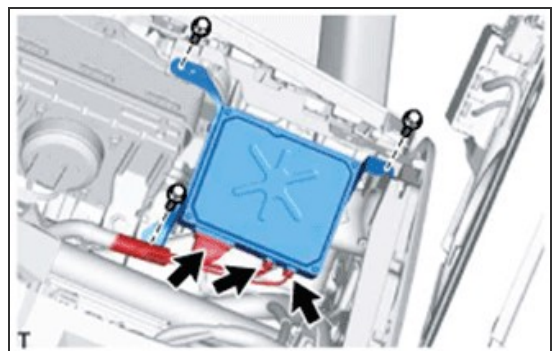

28. REMOVE NO. 2 INSTRUMENT PANEL GARNISH SUB-ASSEMBLY

- a. Put protective tape around the No. 2 instrument panel garnish sub-assembly.

Text in Illustration

*1	Protective Tape
----	-----------------

- b. Remove the 2 screws <G> from the back of the No. 2 instrument panel garnish sub-assembly.
- c. Using a moulding remover, detach the 8 clips and remove the No. 2 instrument panel garnish sub-assembly.

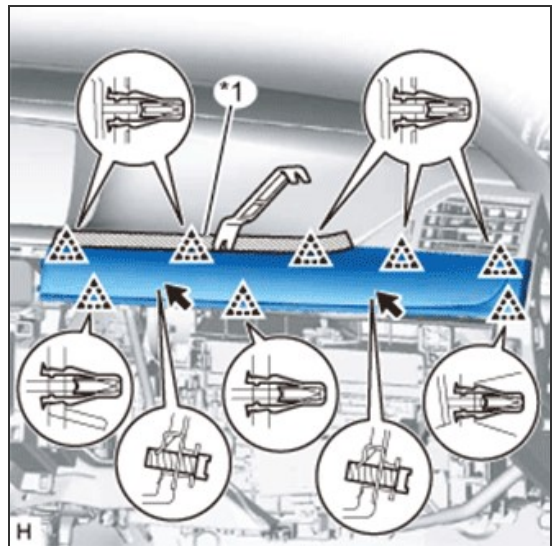

29. REMOVE NO. 3 INSTRUMENT PANEL REGISTER ASSEMBLY

- a. Put protective tape around the No. 3 instrument panel register assembly.

Text in Illustration

*1	Protective Tape
----	-----------------

- b. Using a moulding remover, detach the 4 clips and claw.
- c. Disconnect the connector and remove the No. 3 instrument panel register assembly.

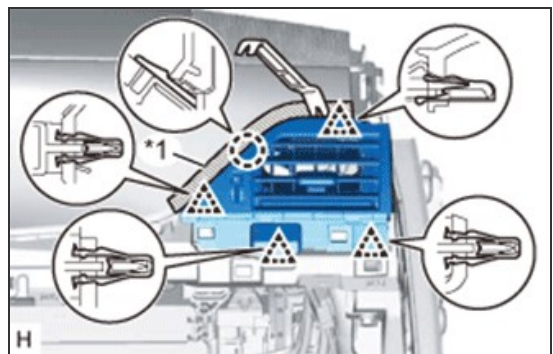

30. REMOVE NO. 1 INSTRUMENT PANEL SPEAKER PANEL SUB-ASSEMBLY

- a. Put protective tape around the No. 1 instrument panel speaker panel sub-assembly.
- b. Using a screwdriver, detach the 2 clips and 2 guides and remove the No. 1 instrument panel speaker panel sub-assembly.

HINT:

Tape the screwdriver tip before use.

Text in Illustration

*1	Protective Tape
----	-----------------

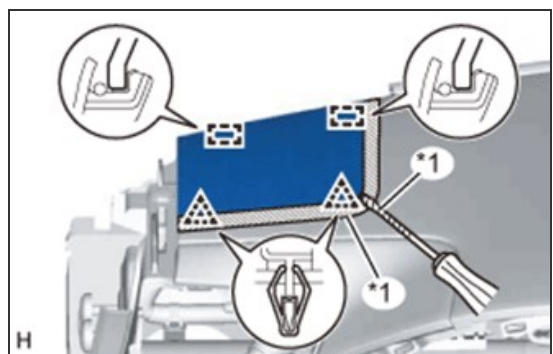

31. REMOVE NO. 2 INSTRUMENT PANEL SPEAKER PANEL SUB-ASSEMBLY