

REPLACEMENT

HINT:

For components of pneumatic cylinder assy RR LH, refer to page 27-6.

1. **REMOVE PNEUMATIC CYLINDER ASSY REAR LH**
 - (a) Jack up vehicle and support the frame with safety stands.

NOTICE:

- **Do the work with the rear axle assy lowered.**
 - **Do the work with the shock absorber installed.**
- (b) Disconnect the height control tube (See page 25-1).
 - (c) Remove the clip on the upper side of the pneumatic cylinder (See page 25-1).

HINT:

If the clip cannot easily be removed, thread a wire through the hole to pull it.

- (d) Discharge air from the pneumatic cylinder assy to retract it.

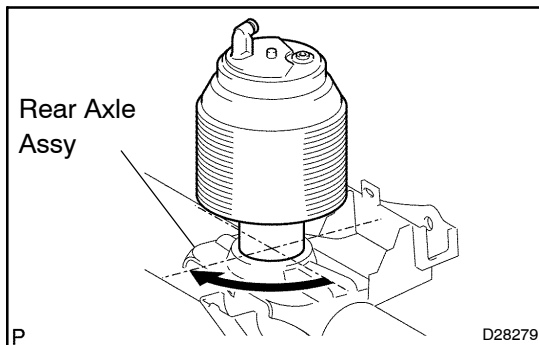
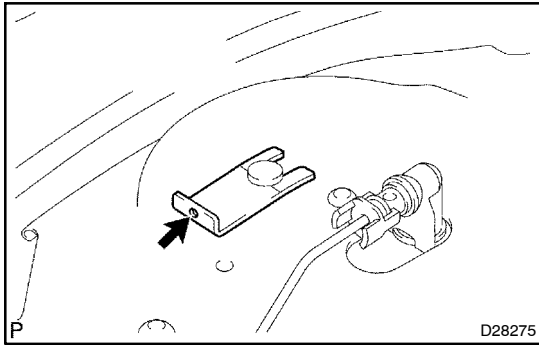

- (e) Turn the pneumatic cylinder assy 90 degrees and remove it from the rear axle assy.

NOTICE:

Do not extend the pneumatic cylinder assy.

HINT:

If the pneumatic cylinder assy is to be reused, 2 new o-rings as well as a new plate and height control plug must be used (See page 25-1).

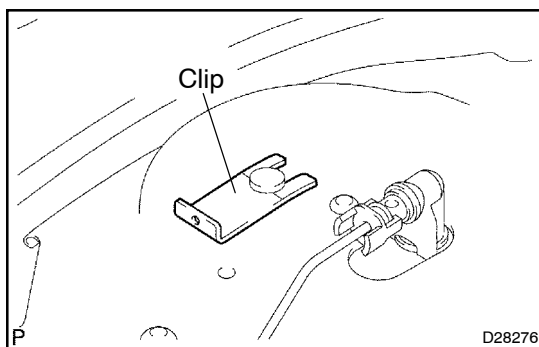

2. **INSTALL PNEUMATIC CYLINDER ASSY REAR LH**
 - (a) Install the pneumatic cylinder assy with the clip.

NOTICE:

Make sure that the clip is secured tightly onto the cylinder.

- (b) Connect the height control tube (See page 25-1).

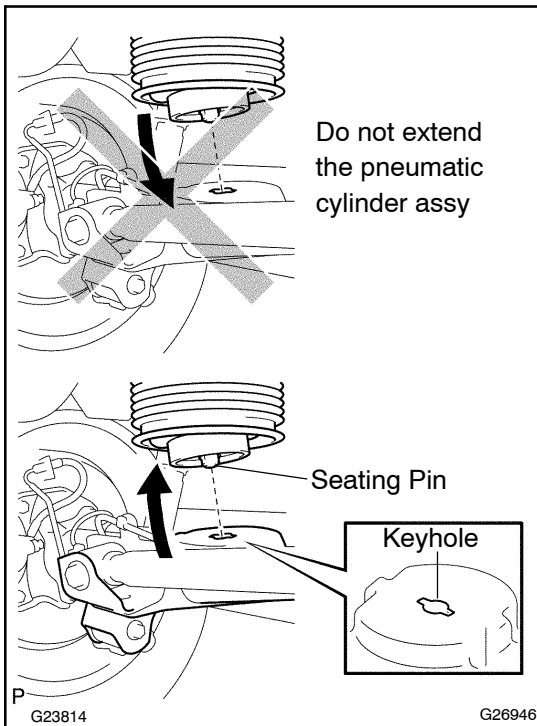

- (c) When using safety stands and jack:
- (1) Jack up the rear axle assy until the bottom of the pneumatic cylinder assy touches the rear axle assy and install the seating pin at the lower side of the pneumatic cylinder assy into the keyhole in the rear axle assy.

NOTICE:

- **Do not extend the pneumatic cylinder assy for clip installation.**
 - **Make sure that the seating pin at the lower side of the pneumatic cylinder assy fits in the keyhole in the rear axle assy.**
- (2) Remove the safety stands with care not to extend the pneumatic cylinder assy when jacking down the vehicle till it sits on the ground.

NOTICE:

- **Do not extend the pneumatic cylinder assy by lowering the rear axle assy with safety stands installed.**
- **Make sure that the diaphragm of the pneumatic cylinder assy is not deformed.**

- (d) When using a swing arm type lift:
- (1) Lower the vehicle till the tires hit the ground, and continue lowering slowly until the bottom of the pneumatic cylinder assy touches the rear axle assy.
 - (2) Align the seating pin on the cylinder with the keyhole in the rear axle assy and install the pneumatic cylinder assy on the rear axle assy.
 - (3) Lower the lift carefully so as not to extend the pneumatic cylinder assy.

NOTICE:

- **Do not extend the pneumatic cylinder assy by lifting up the rear axle housing after installing the seating pin.**
- **Make sure that the diaphragm of the pneumatic cylinder assy is not deformed.**

- (e) Start the engine and replenish the pneumatic cylinder assy with air.

3. **INSPECT AIR LEAK (See page 25-3)**
4. **INSPECT VEHICLE HEIGHT (See page 25-3)**