

<b>DTC</b>	<b>C1713/13</b>	<b>RIGHT REAR HEIGHT CONTROL SENSOR CIRCUIT</b>
------------	-----------------	---

<b>DTC</b>	<b>C1714/14</b>	<b>LEFT REAR HEIGHT CONTROL SENSOR CIRCUIT</b>
------------	-----------------	--

## CIRCUIT DESCRIPTION

Inside the sensor, a brush integrated with the control sensor rotor shaft moves above the resistor, providing linear output. Since the resistance value between the brush and resistor terminal changes in proportion to the shaft rotation angle, the fixed voltage applied to the resistor by ECU is modified by the sensor and output to the ECU as a voltage indicating the shaft rotation angle.

DTC No.	DTC Detecting Condition	Trouble Area
C1713/13	With the ignition switch ON, a voltage of 4.7 V or more or 0.3 V or less at each height control sensor sub-assy rear is detected for 1 sec.	<ul style="list-style-type: none"> <li>• Height control sensor sub-assy rear RH</li> <li>• Right rear height control sensor circuit</li> <li>• Suspension control ECU</li> </ul>
C1714/14		<ul style="list-style-type: none"> <li>• Height control sensor sub-assy rear LH</li> <li>• Left rear height control sensor circuit</li> <li>• Suspension control ECU</li> </ul>

### HINT:

- Once the ECU stores DTC C1713/13 or C1714/14 in the memory, vehicle height control is suspended not carried out until a normal signal is input to the ECU from the height control sensor sub-assy. However, the control resumes if the ignition switch is once turned OFF, and then turned ON again.
- When the suspension control ECU detects a malfunction in the height control sensor, the height control indicator lamp "N" comes on or blinks, and the height control switch ("HI" and "LO") is suspended.
- When either one of the right or left height control sensor sub-assy is faulty, the suspension control ECU uses the other one (functioning one) to adjust the vehicle height to the normal height. When both of the height control sensor sub-assy are faulty, the suspension control ECU suspend the height control function immediately.

# WIRING DIAGRAM

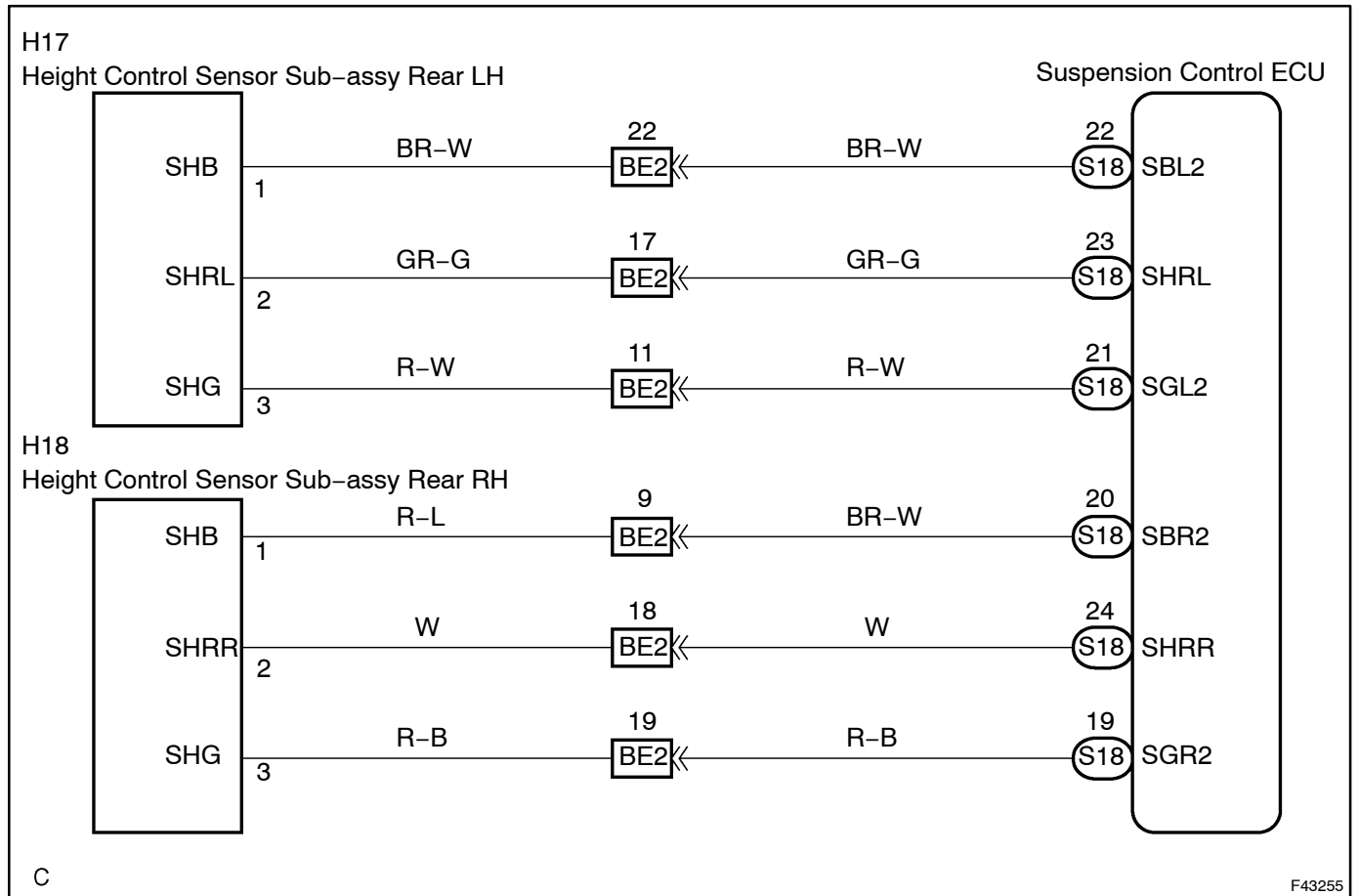

## INSPECTION PROCEDURE

### HINT:

- Proceed to troubleshooting following the flow chart, regardless of whether or not DTC C1713/13 or C1714/14 is displayed.
- If DTC C1761/61 (ECU malfunction) and/or C1774/74 (power source circuit) is displayed, perform the inspection necessary for DTC C1761/61 (See page 05-518) and/or C1774/74 (See page 05-520) first.  
(If DTC C1761/61 and C1774/74 are output at the same time, perform the inspection necessary for DTC C1774/74 first.)
- Start the inspection from step 1 when using the hand-held tester, and start from step 2 when not using the hand-held tester.

### 1 READ VALUE OF HAND-HELD TESTER

- Connect the hand-held tester to DLC3.
- Turn the ignition switch ON, and push the hand-held tester main switch ON.
- Select the item "RL HEIGHT" or "RR HEIGHT" in the DATA LIST, and read its value displayed on the hand-held tester.
- Check the vehicle height value of the height control sensor sub-assy rear with the hand-held tester while pressing the height control switch "UP" and "DOWN".

#### Standard:

Vehicle height value changes.

OK

**CHECK AND REPLACE SUSPENSION CONTROL ECU (See page 01-36)**

NG

### 2 CHECK HARNESS AND CONNECTOR(HEIGHT CONTROL SENSOR SUB-ASSY REAR POWER SOURCE)

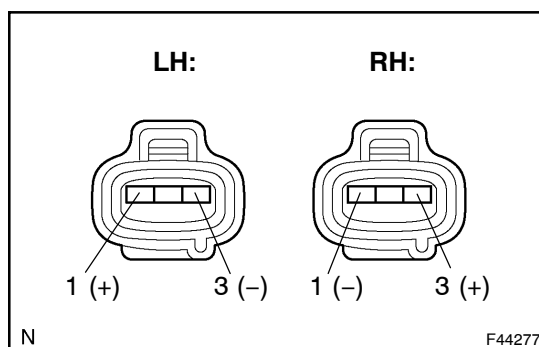

- Disconnect the height control sensor sub-assy rear connector.
- Height control sensor sub-assy rear LH:  
Turn the ignition switch ON, and measure voltage between terminals 1 (SHB) and 3 (SHG) of the height control sensor sub-assy rear wire harness side connector.

#### Standard:

**4.5 to 5.5 V**

- Height control sensor sub-assy rear RH:  
Turn the ignition switch ON, and measure voltage between terminals 1 (SHG) and 3 (SHB) of the height control sensor sub-assy rear wire harness side connector.

#### Standard:

**4.5 to 5.5 V**

OK

**Go to step 4**

NG

<b>3</b>	<b>CHECK HARNESS AND CONNECTOR(HEIGHT CONTROL SENSOR SUB-ASSY REAR - SUSPENSION CONTROL ECU)</b>
----------	--

**Height control sensor sub-assy rear LH:**

- (a) Check for open and short circuit in the harness and the connector between terminal 1 (SHB) of the height control sensor sub-assy rear and S18-22 (SBL2) of the suspension control ECU (See page [01-36](#)).
- (b) Check for open and short circuit in the harness and the connector between terminal 3 (SHG) of the height control sensor sub-assy rear and S18-21 (SGL2) of the suspension control ECU (See page [01-36](#)).

**Height control sensor sub-assy rear RH:**

- (a) Check for open and short circuit in the harness and the connector between terminal 1 (SHG) of the height control sensor sub-assy rear and S18-19 (SGR2) of the suspension control ECU (See page [01-36](#)).
- (b) Check for open and short circuit in the harness and the connector between terminal 3 (SHB) of the height control sensor sub-assy rear and S18-20 (SBR2) of the suspension control ECU (See page [01-36](#)).

<b>NG</b>	<b>REPAIR OR REPLACE HARNESS OR CONNECTOR</b>
-----------	---

<b>OK</b>
-----------

<b>4</b>	<b>CHECK HARNESS AND CONNECTOR(HEIGHT CONTROL SENSOR SUB-ASSY REAR - SUSPENSION CONTROL ECU)</b>
----------	--

**Height control sensor sub-assy rear LH:**

- (a) Check for open and short circuit in the harness and the connector between terminal 2 (SHRL) of the height control sensor sub-assy rear and S18-23 (SHRL) of the suspension control ECU (See page [01-36](#)).

**Height control sensor sub-assy rear RH:**

- (a) Check for open and short circuit in the harness and the connector between terminal 2 (SHRR) of the height control sensor sub-assy rear and S18-24 (SHRR) of the suspension control ECU (See page [01-36](#)).

<b>NG</b>	<b>REPAIR OR REPLACE HARNESS OR CONNECTOR</b>
-----------	---

<b>OK</b>
-----------

**5 INSPECT HEIGHT CONTROL SENSOR SUB-ASSY REAR**

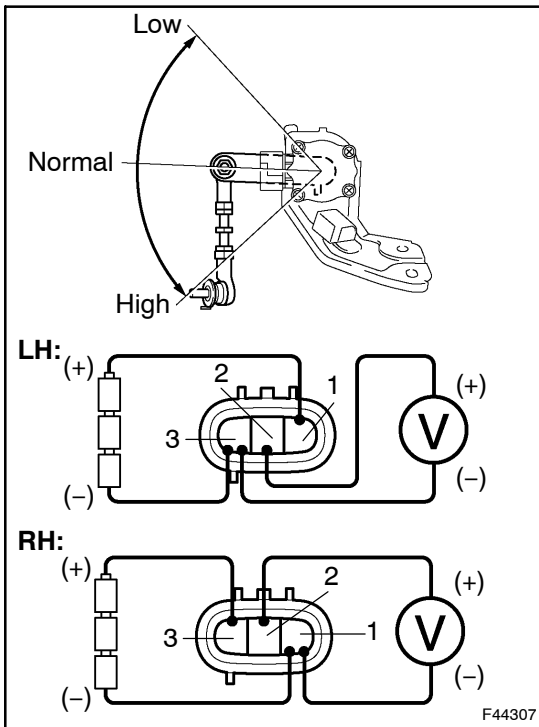

- (a) Remove the height control sensor sub-assy rear LH or RH.
- (b) Connect 3 dry batteries of 1.5 V in series.
- (c) Height control sensor sub-assy rear LH: Connect terminal 1 (SHB) to the batteries' positive (+) terminal, and terminal 3 (SHG) to the batteries' negative (-) terminal, then apply approximately 4.5 V between terminal 2 (SHRL) and 3 (SHG) in the following conditions.

**Standard:**

Position	Voltage
High (0° to 45°)	Approx. 2.53 to 4.33 V
Normal (0°)	Approx. 2.53 V
Low (0° to -45°)	Approx. 0.81 to 2.53 V

**Result:**

OK	A
NG	B

- (d) Height control sensor sub-assy rear RH: Connect terminal 3 (SHB) to the batteries' positive (+) terminal, and terminal 1 (SHG) to the batteries' negative (-) terminal, then apply approximately 4.5 V between terminal 1 (SHG) and 2 (SHRR) in the following conditions.

**Standard:**

Position	Voltage
High (0° to 45°)	Approx. 2.53 to 4.33 V
Normal (0°)	Approx. 2.53 V
Low (0° to -45°)	Approx. 0.81 to 2.53 V

**Result:**

OK	A
NG	C

**B** → REPLACE HEIGHT CONTROL SENSOR SUB-ASSY REAR LH

**C** → REPLACE HEIGHT CONTROL SENSOR SUB-ASSY REAR RH

**A**

**CHECK AND REPLACE SUSPENSION CONTROL ECU (See page 01-36)**