

## LUBRICATION SYSTEM > GENERAL

### OUTLINE

- a. The lubrication circuit is fully pressurized and all oil passes through an oil filter.
- b. A cycloid rotor type oil pump is used.
- c. An oil filter with a replaceable element is used.

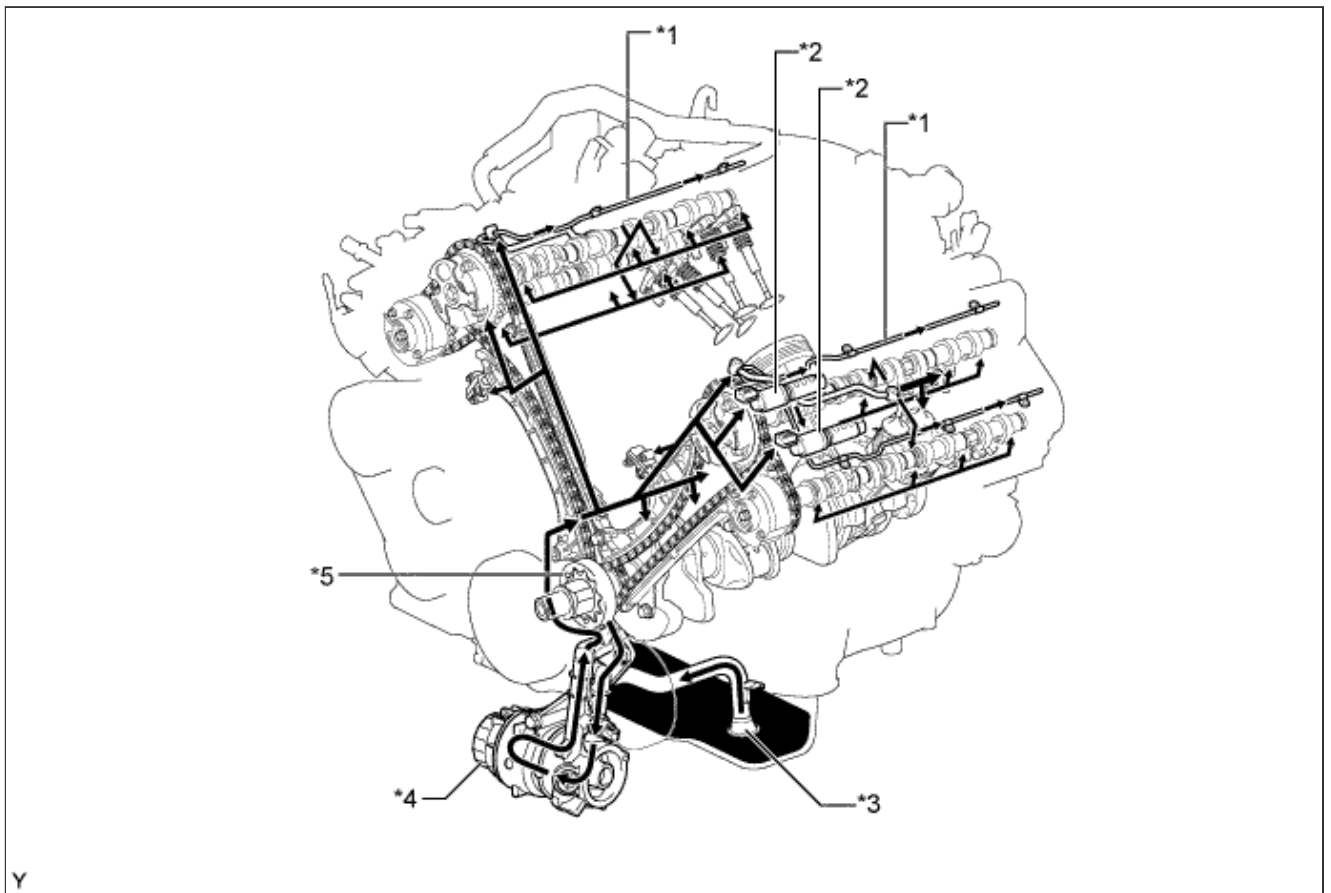

#### Text in Illustration

*1	Oil Delivery Pipe (Cylinder Head Cover)	*2	Camshaft Timing Oil Control Valve Assembly
*3	Oil Strainer	*4	Oil Filter
*5	Oil Pump	-	-

