

HEADLIGHT ASSEMBLY > ADJUSTMENT

for Preparation [Click here](#)

HINT:

- Use the same procedure for the RH and LH sides.
- The procedure listed below is for the LH side.

1. VEHICLE PREPARATION FOR HEADLIGHT AIMING ADJUSTMENT

a. Prepare the vehicle:

- Make sure that there is no damage to the body around the headlights.
- Fill the fuel tank.
- Make sure that the oil is filled to the specified level.
- Inflate the tires to the appropriate pressure.
- Unload the trunk and vehicle, making sure that the spare tire, tools and jack are also removed.
- Have a person of average weight (75 kg, 165 lb) sit in the driver seat.

2. PREPARATION FOR HEADLIGHT AIMING (Using a screen)

a. Prepare the vehicle:

Text in Illustration

*a	25 or 3 m
----	-----------

- Place the vehicle in a location that is dark enough to clearly observe the cutoff line. The cutoff line is a distinct line, below which light from the headlights can be observed and above which it cannot.
- Place the vehicle at a 90° angle to the wall.
- Create a 25 m (82.0 ft.) distance between the vehicle (headlight bulb center) and wall.
- Make sure that the vehicle is on a level surface.
- Bounce the vehicle up and down to settle the suspension.

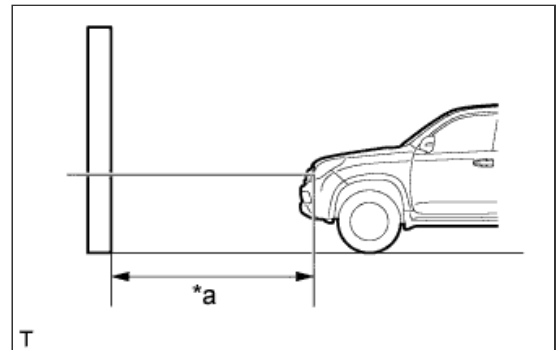

NOTICE:

A distance of 25 m (82.0 ft.) between the vehicle (headlight bulb center) and wall is necessary for proper aim adjustment. If unavailable, secure a distance of exactly 3 m (9.84 ft.) for the check and adjustment (the target zone will change with the distance, so follow the instructions in the illustration).

- b.** Prepare a piece of thick white paper approximately 2 m (6.56 ft.) (height) x 4 m (13.1 ft.) (width) to use as a screen.
- c.** Draw a vertical line down the center of the screen (V line).

d. Set the screen as shown in the illustration.

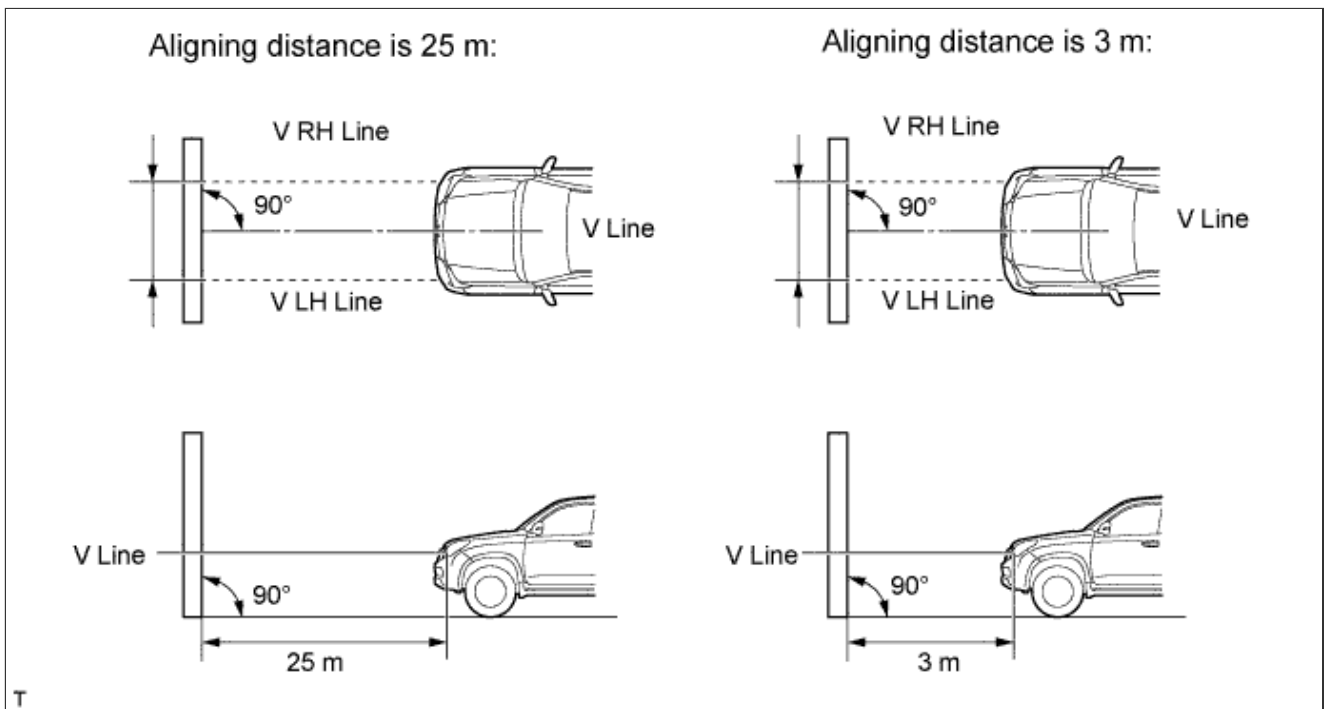

HINT:

- Stand the screen perpendicular to the ground.
- Align the V line on the screen with the center of the vehicle.

e. Draw base lines (H, V LH, and V RH Lines) on the screen as shown in the illustration.

Text in Illustration

*a	V LH Line
*b	V Line
*c	V RH Line
*d	H Line
*e	Ground

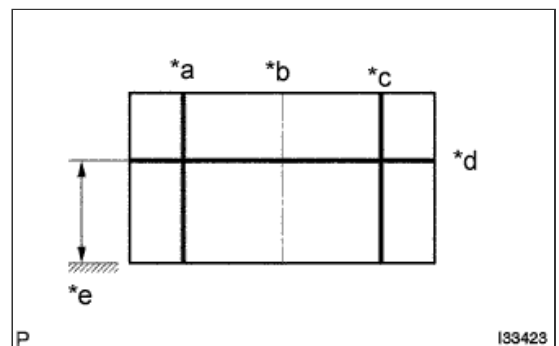

HINT:

- The base lines differ for "low beam inspection" and "high beam inspection".
- Mark the headlight bulb center marks on the screen. If the center mark cannot be observed on the headlight, use the center of the headlight bulb or the name of the manufacturer marked on the headlight as the center mark.

i. H Line (Headlight):

Draw a horizontal line across the screen so that it passes through the center marks. The

H line should be at the same height as the headlight bulb center marks of the low beam headlights.

- ii. V LH Line, V RH Line (Center mark position of the left-hand (LH) and right-hand (RH) headlights):

Draw two vertical lines so that they intersect the H line at each center mark (aligned with the center of the low beam headlight bulbs).

3. INSPECT HEADLIGHT AIMING

- a. Cover the headlight or disconnect the connector of the headlight on the opposite side to prevent light from the headlight that is not being inspected from affecting the headlight aiming.

Text in Illustration

*a	25 or 3 m
----	-----------

NOTICE:

Do not keep the headlight covered for more than 3 minutes. The headlight lens is made of synthetic resin, which may melt or be damaged due to excessive heat.

HINT:

When checking the aim of the high beam headlight, cover the low beam headlight or disconnect the connector.

- b. Start the engine.

- c. Turn on the headlight and check if the cutoff line matches the preferred cutoff line in the following illustration.

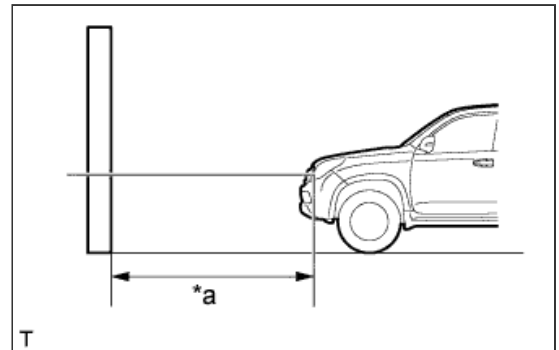

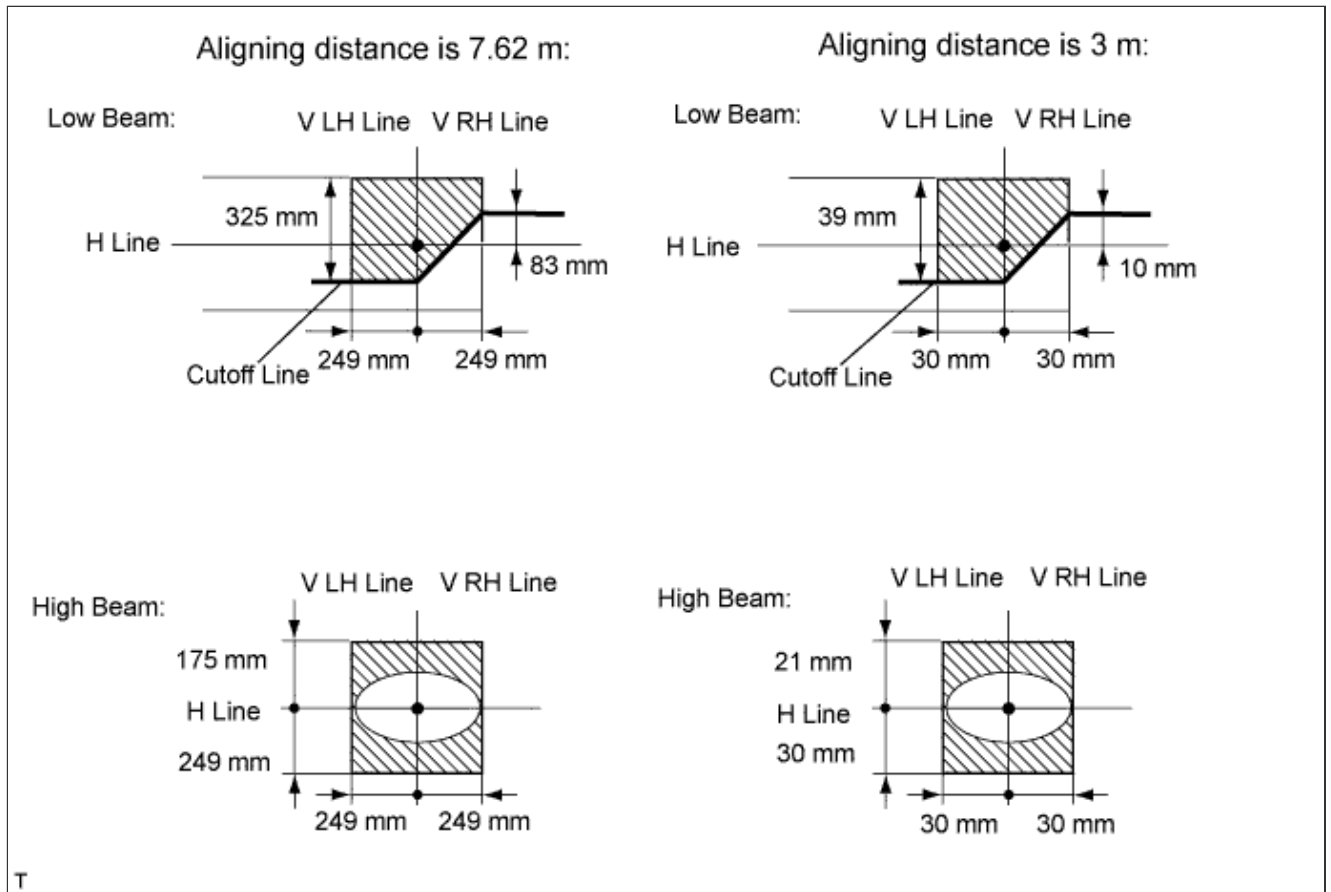

HINT:

- The low beam and high beam headlight are a unit. Adjusting the aim on the low beam to the correct position should also result in the high beam adjustment being correct.
- If the alignment distance is 25 m (82.0 ft.): The low beam cutoff line should be within 249 mm (9.80 in.) above or below the H line as well as 249 mm (9.80 in.) left or right of the V line.
- If the alignment distance is 3 m (9.84 ft.): The low beam cutoff line should be within 30 mm (1.18 in.) above or below the H line as well as 30 mm (1.18 in.) left or right of the V line.
- If the alignment distance is 25 m (82.0 ft.): The high beam center of intensity should be within 249 mm (9.80 in.) above or below the H line as well as 249 mm (9.80 in.) left or right of the V line.
- If the alignment distance is 3.0 m (1.17 ft.): The high beam center of intensity should be within 30 mm (1.18 in.) above or below the H line as well as 30 mm (1.18 in.) left or right of the V line.

4. ADJUST HEADLIGHT AIMING

a. Headlight low beam.

i. Using a screwdriver, adjust the aim.

Text in Illustration

*1	Vertical Aiming
*2	Horizontal Aiming
*3	Screwdriver

Adjust the aim of each headlight to the specified range by turning each aiming screw with a screwdriver.

NOTICE:

The final turn of the aiming screw should be made in the clockwise direction. If the screw is tightened excessively, loosen it, and then retighten it so that the final turn of the screw is in the clockwise direction.

HINT:

- The low beam and high beam headlight are a unit. Adjusting the aim on the low beam to the correct position should also result in the high beam adjustment being correct.
- If it is not possible to correctly adjust headlight aim, check the bulb, headlight unit and headlight unit reflector installation.
- The headlight aim moves up when turning the vertical aiming screw clockwise, and moves down when turning the vertical aiming screw counterclockwise. The headlight aim moves right when turning the horizontal aiming screw clockwise, and moves left when turning the horizontal aiming screw counterclockwise.

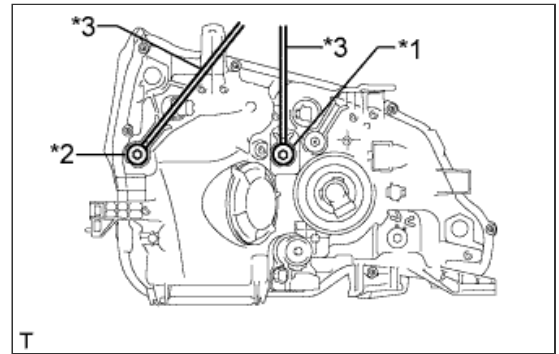

b. Headlight high beam.

i. Using a screwdriver, adjust the aim.

Text in Illustration

*1	Vertical Aiming
*2	Horizontal Aiming
*3	Screwdriver

Adjust the aim of each headlight to the specified range by turning each aiming screw with a screwdriver.

NOTICE:

The final turn of the aiming screw should be made in the clockwise direction. If the screw is tightened excessively, loosen it, and then retighten it so that the final turn of the screw is in the clockwise direction.

HINT:

- The low beam and high beam headlight are a unit. Adjusting the aim on the low beam to the correct position should also result in the high

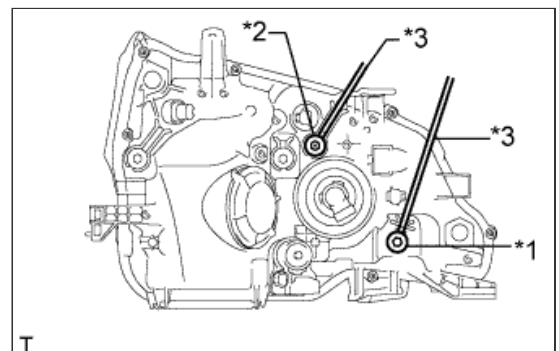

beam adjustment being correct.

- **If it is not possible to correctly adjust headlight aim, check the bulb, headlight unit and headlight unit reflector installation.**
- **The headlight aim moves up when turning the vertical aiming screw clockwise, and moves down when turning the vertical aiming screw counterclockwise. The headlight aim moves right when turning the horizontal aiming screw clockwise, and moves left when turning the horizontal aiming screw counterclockwise.**