

BACK DOOR > DISASSEMBLY

for Preparation [Click here](#)

1. REMOVE BACK DOOR CENTER GARNISH

- a. Detach the 4 clips and remove the back door center garnish.

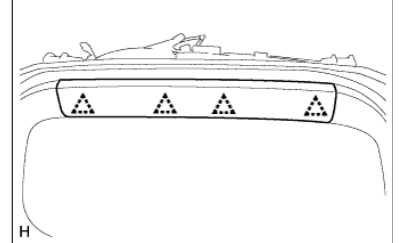

2. REMOVE BACK DOOR SIDE GARNISH LH

- a. Detach the 2 clips and claw and remove the back door side garnish.

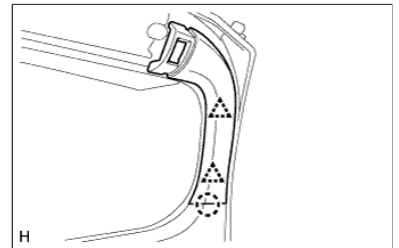

3. REMOVE BACK DOOR SIDE GARNISH RH

- a. Detach the 2 clips and claw and remove the back door side garnish.

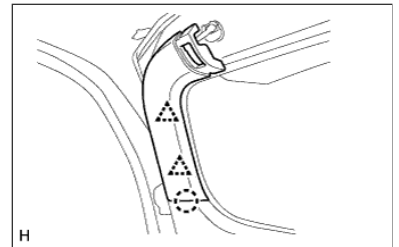

4. REMOVE BACK DOOR TRIM COVER

- a. Remove the back door trim cover as shown in the illustration.

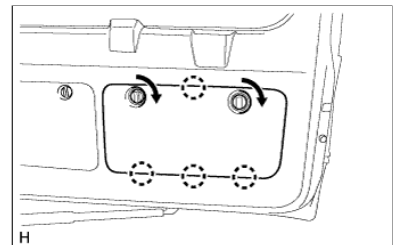

5. REMOVE UPPER TOOL BOX PANEL SUB-ASSEMBLY

- a. Remove the upper tool box panel sub-assembly as shown in the illustration.

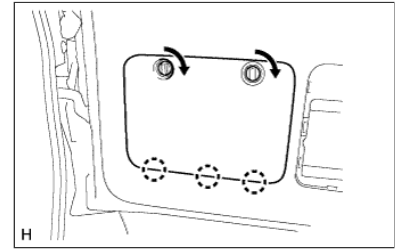

6. REMOVE TOOL CASE

- a. Detach the 2 claws and remove the tool case.

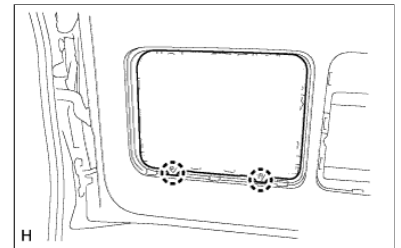

7. REMOVE BACK DOOR LOCK COVER

- a. Using moulding remover B, detach the clip and 6 claws and remove the back door lock cover.

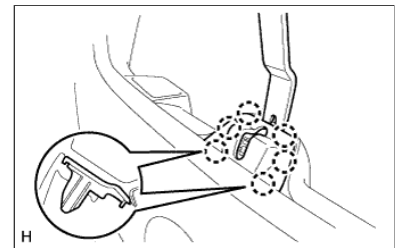

8. REMOVE BACK DOOR TRIM PANEL ASSEMBLY

- a. Detach the claw and remove the cover.

HINT:

Tape the screwdriver tip before use.

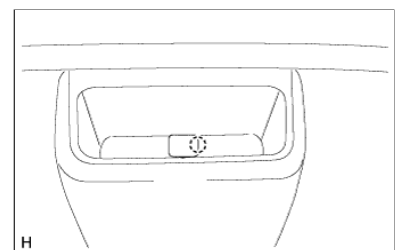

- b. Remove the screw.

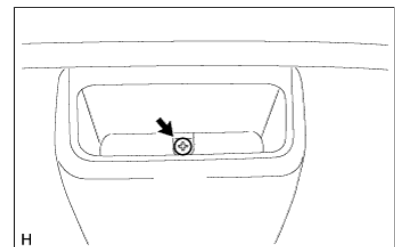

- c. Remove the bolt.
- d. Detach the 15 clips and remove the back door trim panel assembly.

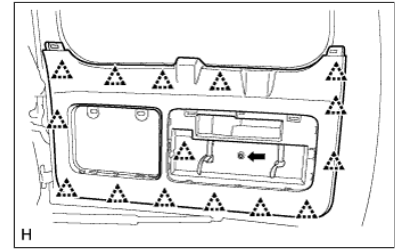

9. REMOVE TOOL BOX BRACKET

- a. Remove the 4 bolts and 2 tool box brackets.

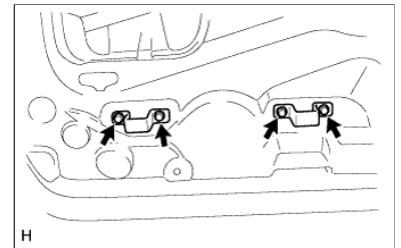

10. REMOVE BACK DOOR SERVICE HOLE COVER

- a. Remove the service hole cover.

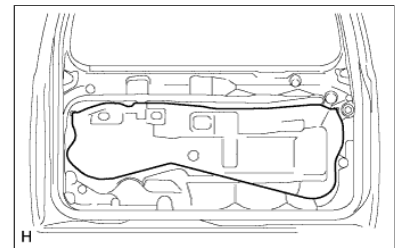

11. REMOVE BACK DOOR LOCK ASSEMBLY

- a. Disconnect the connector.
- b. Using a T30 "TORX" wrench, remove the 3 screws.

NOTICE:

Be careful when removing the bolts as the door lock may fall and become damaged.

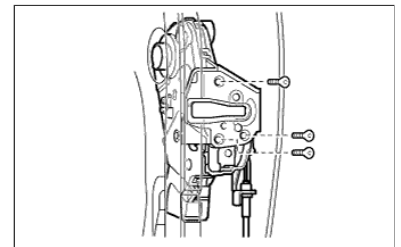

- c. Disconnect the cable and remove the back door lock assembly.
- d. Remove the door lock wiring harness seal from the back door lock assembly.

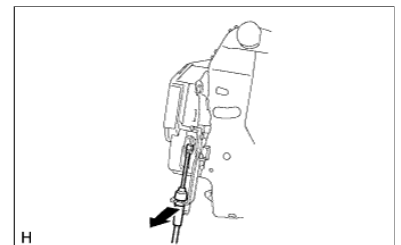

12. REMOVE BACK DOOR LOCK CONTROL CABLE ASSEMBLY

- a. Disconnect the cable.

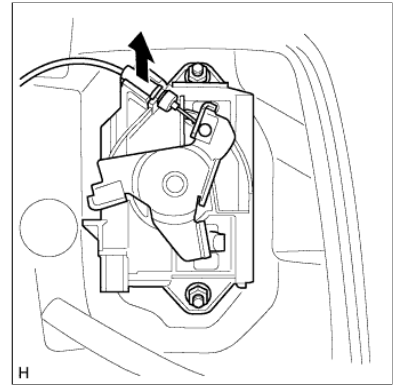

13. REMOVE BACK DOOR OUTSIDE HANDLE LH

- a. Remove the 2 nuts and back door outside handle.
- b. Disconnect the cable.

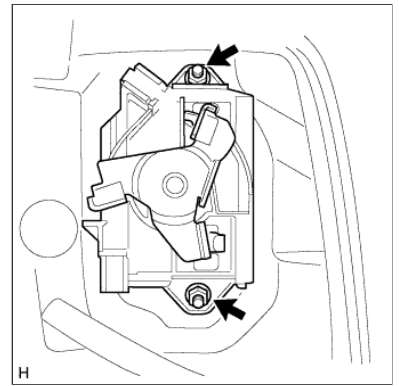

14. REMOVE REAR TELEVISION CAMERA ASSEMBLY

- a. Disconnect the connector.
- b. Remove the 2 bolts and rear television camera.

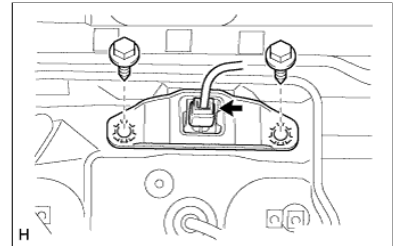

15. REMOVE LOWER BACK DOOR OUTSIDE GARNISH MOULDING LH

- a. Using a screwdriver, detach the 5 claws and remove the outside garnish moulding.

HINT:

Tape the screwdriver tip before use.

Text in Illustration

*1	Protective Tape
----	-----------------

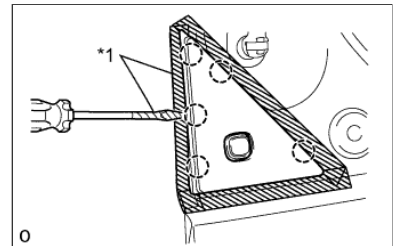

16. REMOVE LOWER BACK DOOR OUTSIDE GARNISH MOULDING RH

- a. Detach the 5 claws and remove the moulding.

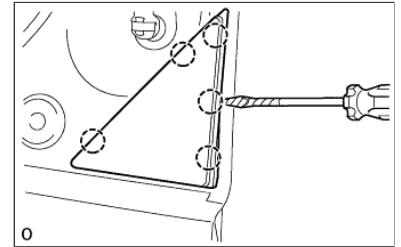

17. REMOVE LOWER BACK DOOR GARNISH SUB-ASSEMBLY OUTSIDE LH

- a. Disconnect the connector and detach the clamp.
- b. Remove the screw.
- c. Detach the double-sided tape.

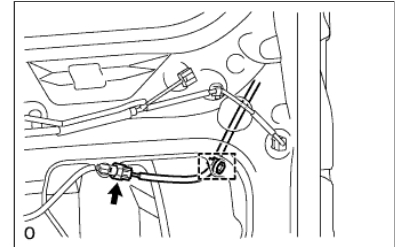

- d. Using a screwdriver, detach the 5 claws and remove the outside garnish.

NOTICE:

Be careful not to damage the vehicle body.

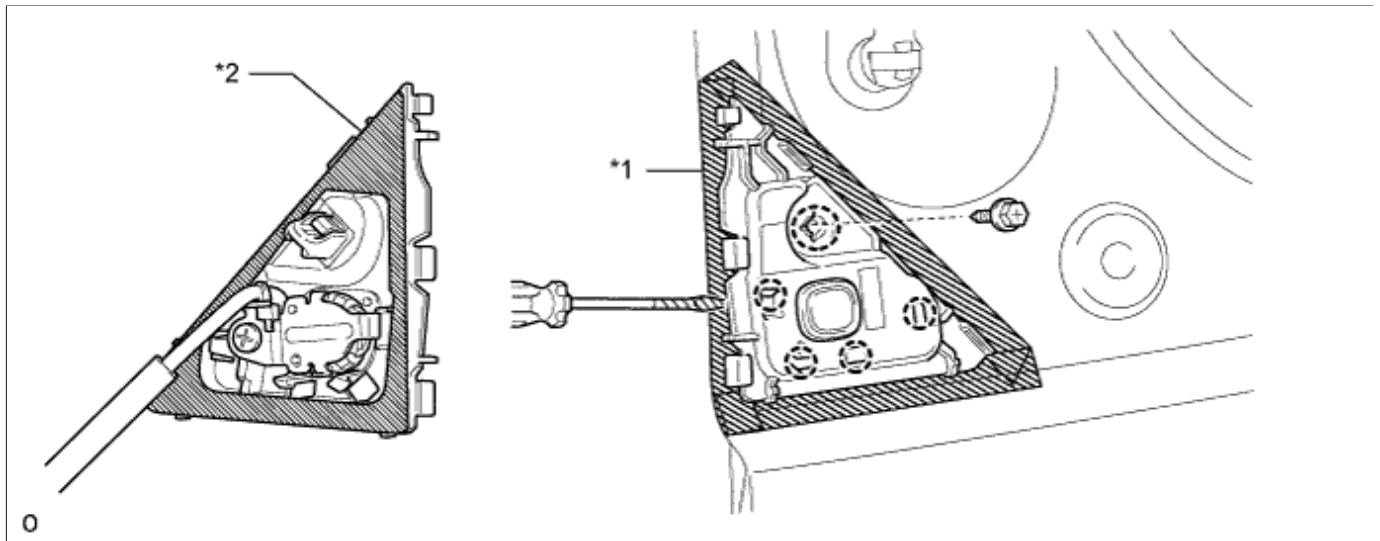

Text in Illustration

*1	Protective Tape	*2	Double-sided Tape
----	-----------------	----	-------------------

18. REMOVE LOWER BACK DOOR GARNISH SUB-ASSEMBLY OUTSIDE RH

- a. Remove the screw.

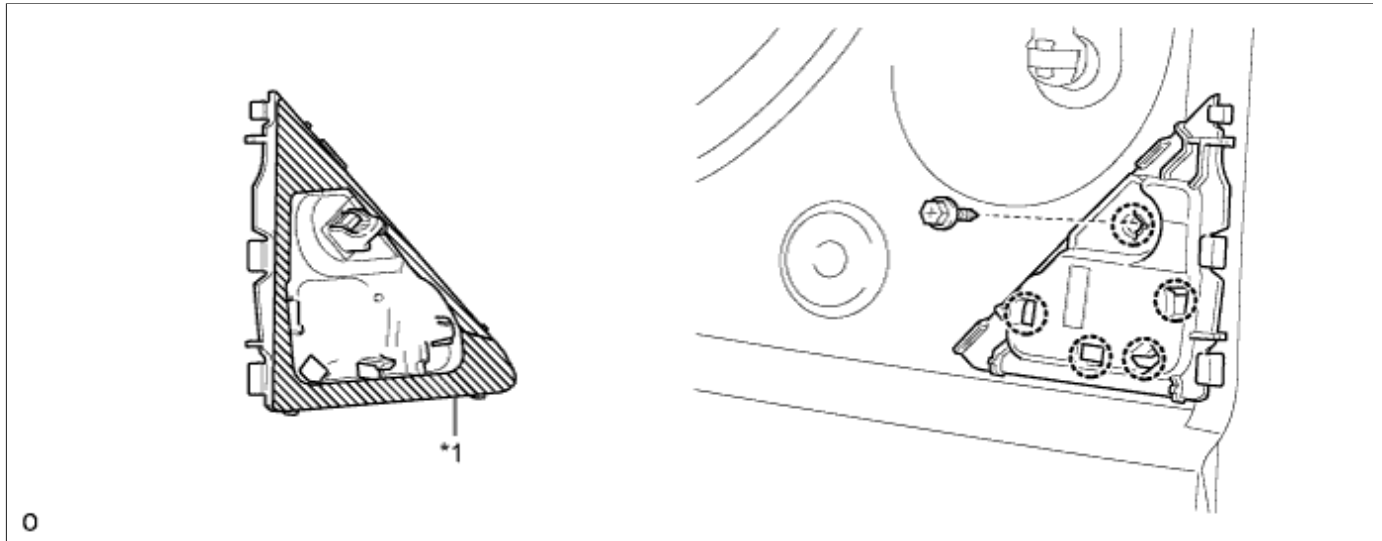

Text in Illustration

*1	Double-sided Tape	-	-
----	-------------------	---	---

- b. Detach the 4 claws and remove the lower door garnish sub-assembly outside.

19. REMOVE GLASS HATCH OPENER SWITCH ASSEMBLY

- a. Remove the screw and opener switch.

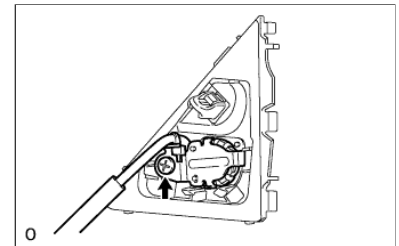

20. REMOVE SWITCH COVER

- a. Remove the switch cover.

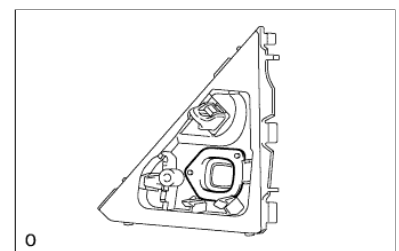

21. REMOVE NO. 2 BACK DOOR WEATHERSTRIP

- a. Remove the No. 2 back door weatherstrip.

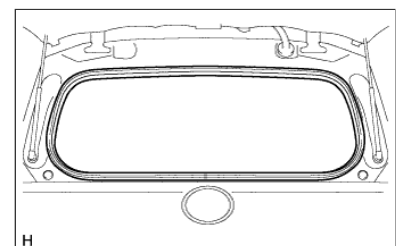

22. REMOVE BACK DOOR SIDE FEMALE STOPPER SUB-ASSEMBLY LH

- a. Remove the 2 bolts and back door side female stopper sub-assembly.

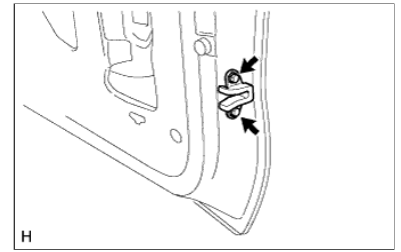

23. REMOVE BACK DOOR NO. 2 STOPPER CUSHION

- a. Remove the back door No. 2 stopper cushion.

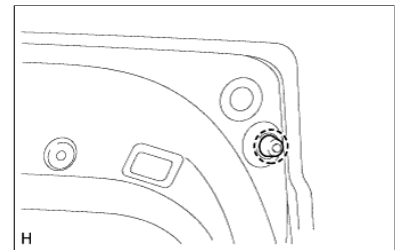

24. REMOVE BACK DOOR NO. 1 STOPPER

- a. Using a clip remover, detach the 2 claws and remove the back door No. 1 stopper.

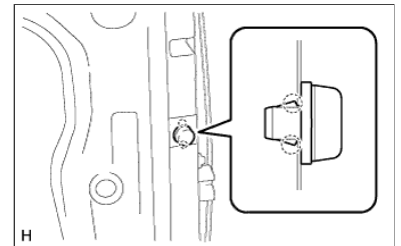

25. REMOVE BACK DOOR PANEL CUSHION

- a. Remove the 4 back door panel cushions.

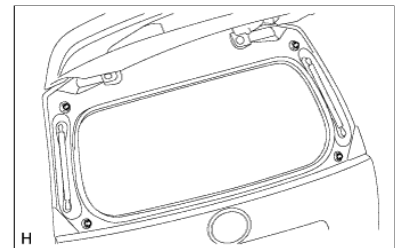

26. REMOVE BACK WINDOW LOCK ASSEMBLY

- a. Disconnect the connector.
- b. Remove the 3 bolts and back window lock assembly.

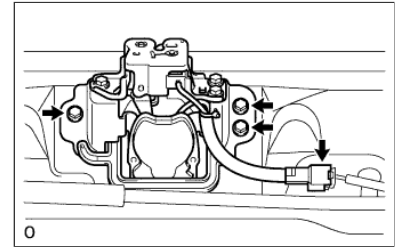

27. REMOVE REAR NO. 1 SPOILER COVER

- a. Detach the fastening tape and 5 clips and remove the rear No. 1 spoiler cover.

Text in Illustration

*1	Fastening Tape
----	----------------

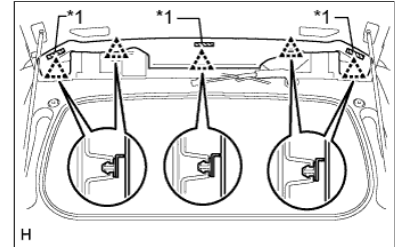

28. REMOVE REAR SPOILER COVER RH

- a. Put protective tape around the rear spoiler cover.
- b. Using a screwdriver, detach the 2 clips and remove the rear spoiler cover as shown in the illustration.

HINT:

Tape the screwdriver tip before use.

Text in Illustration

*1	Protective Tape
----	-----------------

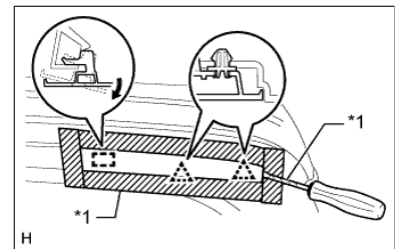

29. REMOVE REAR SPOILER SUB-ASSEMBLY

- a. Disconnect the connector.

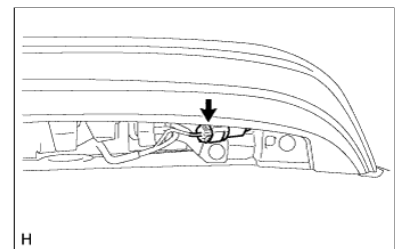

- b. Remove the 6 bolts.

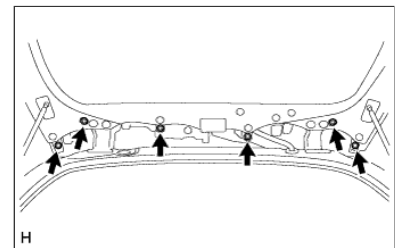

- c. Detach the 3 clips and rear spoiler.

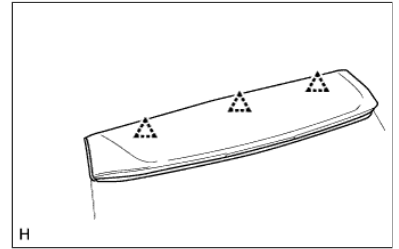

30. REMOVE REAR WASHER NOZZLE SUB-ASSEMBLY

a. Disconnect the hose.

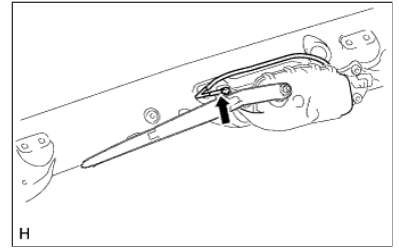

b. Detach the 2 claws and remove the washer nozzle.

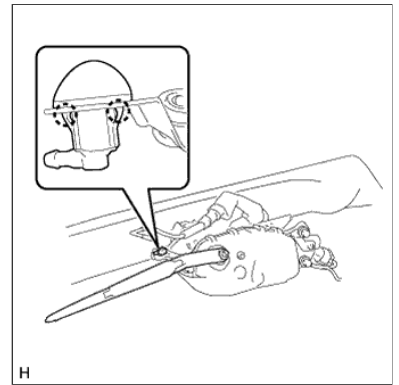

31. REMOVE REAR WIPER ARM

a. Remove the nut and rear wiper arm.

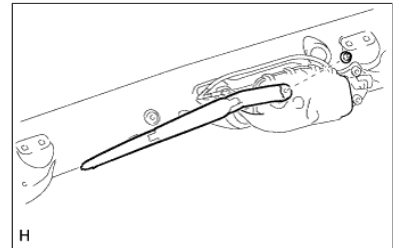

32. REMOVE REAR WIPER MOTOR ASSEMBLY

a. Disconnect the connector.

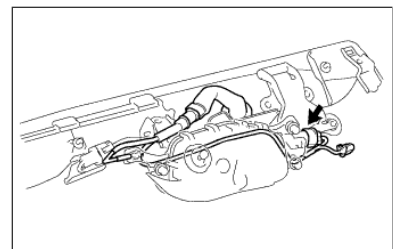

- b. Remove the 3 bolts.
- c. Detach the 2 guides and remove the rear wiper motor.

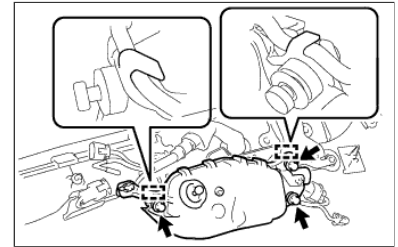

33. REMOVE BACK DOOR LOCK STRIKER COVER

- a. Using a moulding remover, detach the 3 claws and remove the lock striker cover.

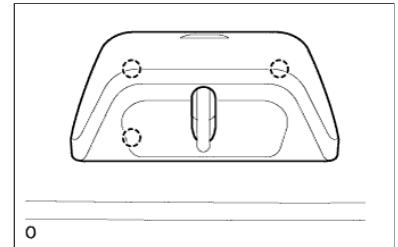

34. REMOVE BACK WINDOW STAY ASSEMBLY LH

- a. Using a screwdriver, remove the 2 stop rings as shown in the illustration, and then remove the back window stay.

CAUTION:

Remove the back window stay while supporting the back door with one hand.

HINT:

Tape the screwdriver tip before use.

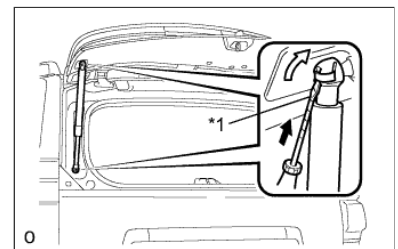

Text in Illustration

*1	Protective Tape
----	-----------------

35. REMOVE BACK WINDOW STAY ASSEMBLY RH

HINT:

Use the same procedure described for the LH side.

36. REMOVE BACK DOOR STAY BOLT

- a. Remove the 2 back door stay bolts.

Text in Illustration

*A	for RH Side
*B	for LH Side

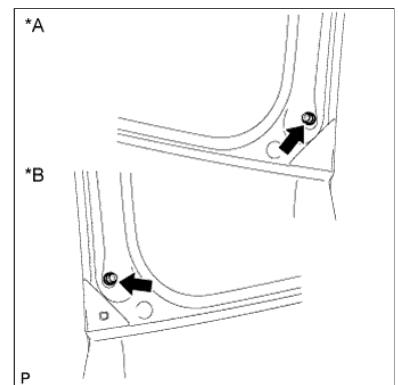

37. REMOVE BACK DOOR GLASS

a. Disconnect the connector and detach the 2 clamps.

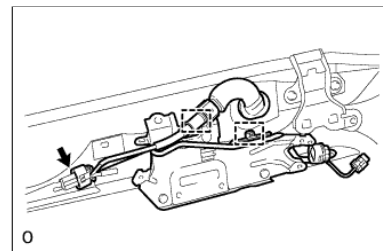

b. Remove the 4 bolts and back window glass.

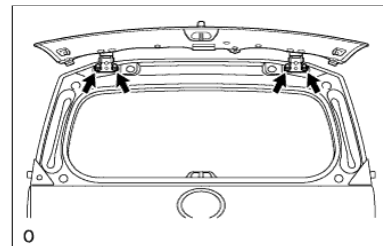

38. REMOVE REAR BUMPER BAR PLATE

a. Put protective tape around the rear bumper bar plate.

b. Detach the 14 claws and remove the rear bumper bar plate.

Text in Illustration

*1	Protective Tape
----	-----------------

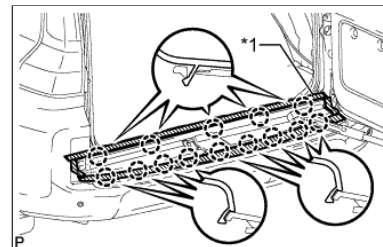

39. REMOVE BACK DOOR CHECK

NOTICE:

- If the back door check is detached from a ball joint, do not reuse it as the connection with the ball joint will be loose, resulting in the back door check falling off.
- If the back door check is detached from a ball joint, it becomes non-reusable. Therefore, do not detach the back door check from a ball joint unless replacing it.

a. Remove the 2 bolts

b. Using a clip remover, detach the clip and remove the back door check with back door lower damper stay bracket.

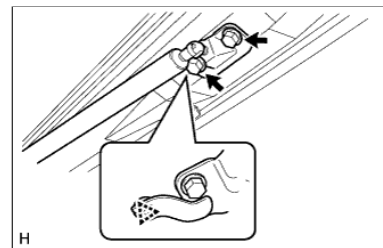

c. Detach the wire harness clamp.

d. Remove the 3 bolts and back door check with back door lower damper stay bracket.

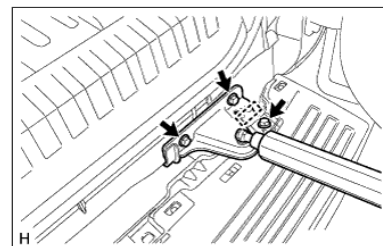

40. REMOVE BACK DOOR LOWER DAMPER STAY BRACKET LH

NOTICE:

- If the back door check is detached from a ball joint, do not reuse it as the connection with the ball joint will be loose, resulting in the back door check falling off.
- If the back door check is detached from a ball joint, it becomes non-reusable. Therefore, do not detach the back door check from a ball joint unless replacing it.

a. Back Door Side:

- i. Using a screwdriver, remove the stop ring as shown in the illustration, and then remove the back door check.

NOTICE:

Tape the screwdriver tip before use.

- ii. Using a clip remover, detach the clip and remove the back door damper stay bracket.

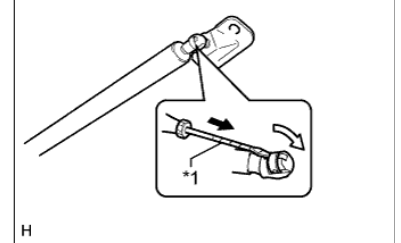

b. Bumper Side:

- i. Using a screwdriver, remove the stop ring as shown in the illustration, and then remove the back door check.

NOTICE:

Tape the screwdriver tip before use.

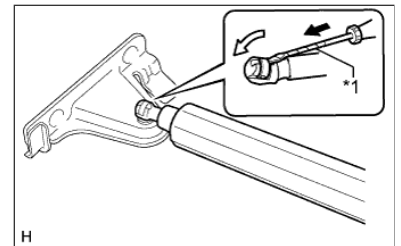

41. REMOVE BACK DOOR OUTSIDE GARNISH SUB-ASSEMBLY

- a. Disconnect the connector and remove the nut.
- b. Detach the 9 clips and remove the back door outside garnish.

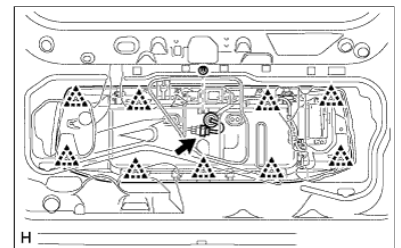

42. REMOVE NO. 1 BACK DOOR GARNISH RETAINER

- a. Remove the 3 screws and No. 1 back door garnish retainer.

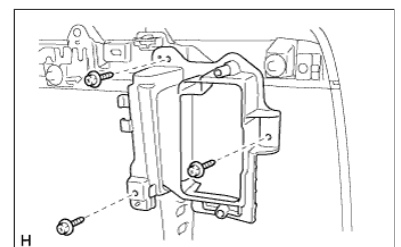

43. REMOVE BACK DOOR ELECTRICAL KEY SWITCH

a. Detach the clamp.

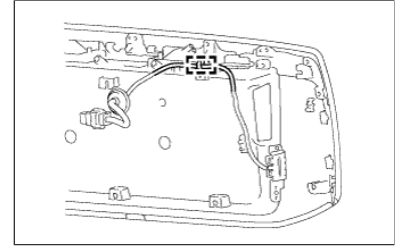

b. Remove the 2 screws.

c. Detach the 2 guides and remove the back door electrical key switch.

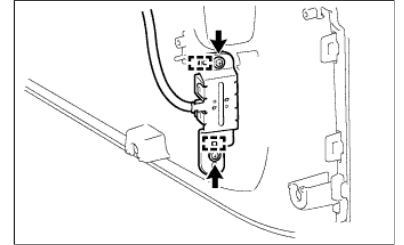

44. REMOVE LICENSE PLATE LIGHT ASSEMBLY

a. Disconnect the connector.

b. Remove the 2 screws and lights.

