

Millimeter Wave Radar Sensor - Floor Slope Compensation

Service Category ADAS/AD

Section Advanced Driver Assistance System

Market USA

Toyota Supports
ASE Certification 

Applicability

YEAR(S)	MODEL(S)	ADDITIONAL INFORMATION
2011 - 2017	CT200H	
2013 - 2015	ES300H	
2007 - 2015	ES350	
2006	GS300	
2007 - 2011, 2013 - 2015	GS350, GS450H	
2006 - 2007	GS430	
2008 - 2011	GS460	
2010 - 2019	GX460	
2010 - 2012	HS250H	
2008 - 2014	IS F	
2016	IS200T	
2006 - 2015	IS250	
2010 - 2015	IS250C, IS350C, RX450H	
2006 - 2016	IS350	
2007 - 2017	LS460	
2008 - 2016	LS600H	
2008 - 2011, 2013 - 2015	LX570	
2015 - 2017	NX200T, NX300H, RC F, RC350	
2016 - 2017	RC200T, RC300	

Millimeter Wave Radar Sensor - Floor Slope Compensation

2011 - 2015	RX350
-------------	-------

Introduction

For proper calibration of the millimeter wave radar sensor, the vehicle and radar target must be on a level surface with a consistent plane. If a level surface with a consistent plane is not available, use the Floor Slope Compensation Procedure in this service bulletin in conjunction with the appropriate model and model year Repair Manual instructions when adjusting the millimeter wave radar sensor.

Warranty Information

OP CODE	DESCRIPTION	TIME	OFF	T1	T2
N/A	Not Applicable to Warranty	–	–	–	–

Required Tools & Equipment

SPECIAL SERVICE TOOLS (SST)	PART NUMBER	QTY
Laser Level*	01816-00103	1
Tri-pod*	01816-00104	1
Attachment A*	09989-00010-01, 09989-00010-L	1
Digital Angle Gauge*	01815-00102	1

*Essential SST.

NOTE
Additional SSTs may be ordered by calling 1-800-933-8335.

REQUIRED TOOLS & MATERIAL	QUANTITY
Tape Measure	1

Millimeter Wave Radar Sensor - Floor Slope Compensation

Floor Slope Compensation Procedure

1. Prepare the vehicle for calibration.
 - A. Park the vehicle where the calibration will be performed.
 - B. Check the tire pressures and adjust as necessary.
 - C. Remove ALL excess weight from the vehicle (heavy objects, luggage, etc.).

2. Determine the floor slope and set the vertical angle of the millimeter wave radar sensor.

NOTE

Refer to the instruction video link: [Floor Slope Measurement and Millimeter Wave Radar Sensor Vertical Angle Calibration Procedure.](#)

Figure 1.

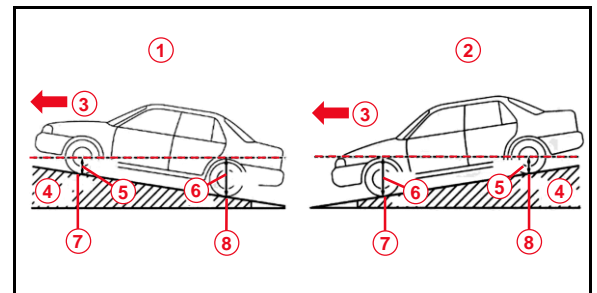

3. Install the laser level onto the tri-pod.
 - A. Install the tri-pod head attachment onto the base of the laser level.
 - B. Engage the tri-pod head attachment onto the tri-pod and lock it in position.

NOTE

Refer to the instruction video link: [3 Line Chalk Line \(Automatic Laser Level\) SST: 01816-001003 Operation Overview.](#)

1	Upward Slope
2	Downward Slope
3	Vehicle Front
4	Floor
5	Short
6	Long
7	Front
8	Rear

Millimeter Wave Radar Sensor - Floor Slope Compensation

Floor Slope Compensation Procedure (continued)

4. Measure the floor slope on BOTH sides of the vehicle.
 - A. Place the tri-pod and laser approximately 6 ft. away from the side of the vehicle.
 - B. Level the tri-pod base and head using the built-in bubble levels.
 - C. Turn the laser ON and ensure that the laser switch is placed in the unlocked position so it can automatically level.

Figure 2.

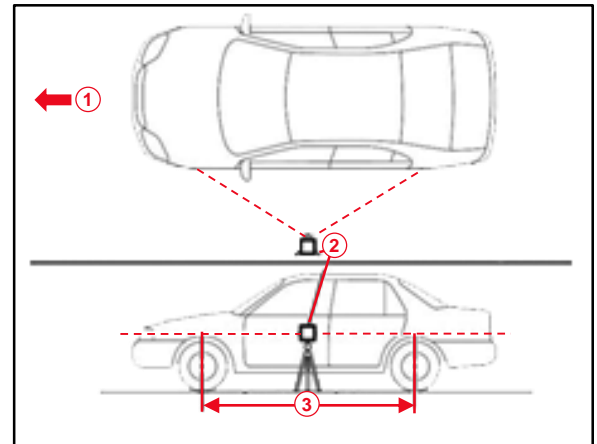

1	Vehicle Front
2	Self-leveling Laser
3	Center of the Wheel

- D. Measure the distance from the floor to the laser line at the vertical center of the front wheel as shown and record the value.

NOTE

Measure using inches or millimeters.

Figure 3.



- E. Measure the distance from the floor to the laser line at the vertical center of the rear wheel and record the value.
- F. Repeat steps 4A – 4E for the opposite side.

Millimeter Wave Radar Sensor - Floor Slope Compensation

Floor Slope Compensation Procedure (continued)

5. Calculate the vertical angle for the millimeter wave radar sensor.
 - A. Open the [Slope Calculator](#), select the appropriate vehicle from the dropdown, and enter the measured values at each wheel in the correct locations.

NOTE

- Ensure the correct measurement value (inches or millimeters) is selected prior to calculating.
- Figure 4 should be used ONLY as a reference, you MUST click on the link to access the [Slope Calculator](#).

- B. Press the finalize button and then press calculate.
- C. The slope calculation sheet will calculate the required vertical angle and reflector height adjustment based on the floor slope. Record these readings.

Figure 4.

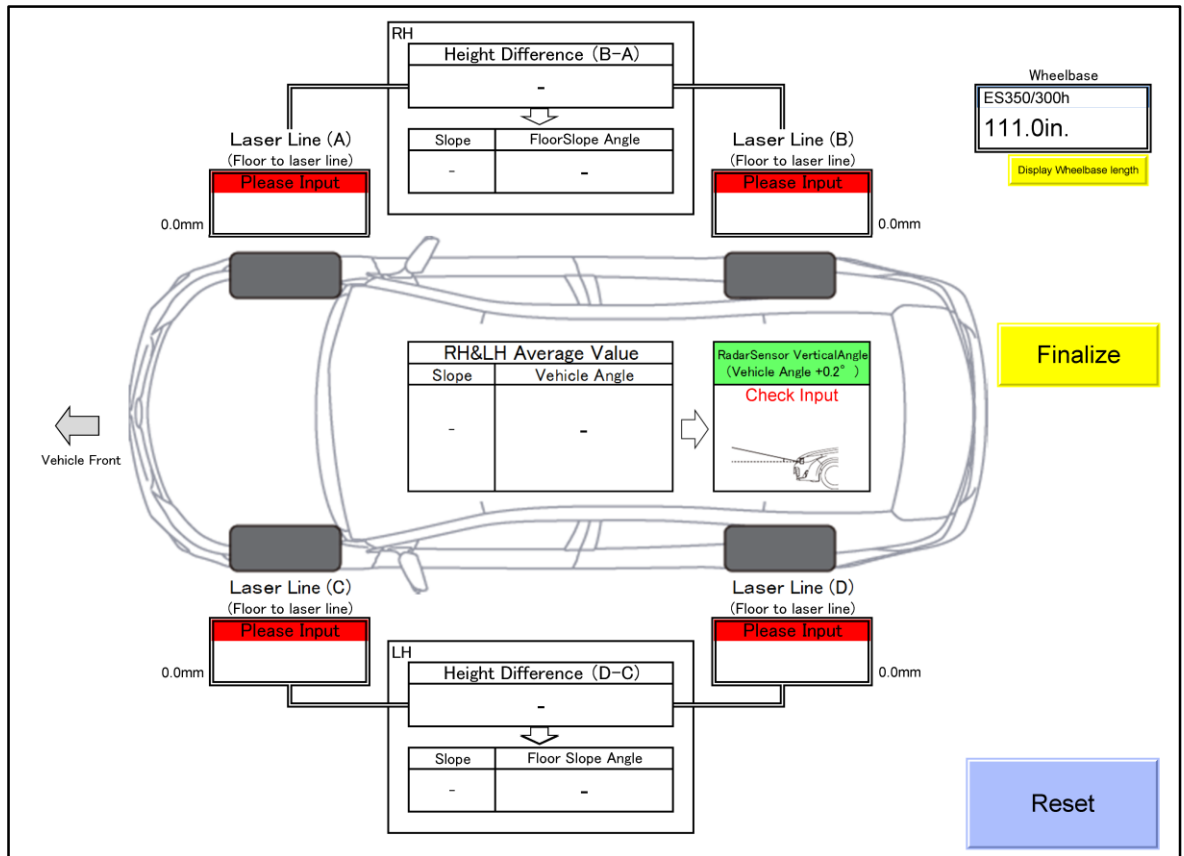

Millimeter Wave Radar Sensor - Floor Slope Compensation

Floor Slope Compensation Procedure (continued)

6. Set the vertical angle of the millimeter wave radar sensor.
 - A. Clean the top of the radar sensor surface and Attachment A and remove ANY dust and/or debris.
 - B. Place Attachment A (short or long depending on available clearance) on top of the radar sensor calibration surface as shown.

Figure 5.

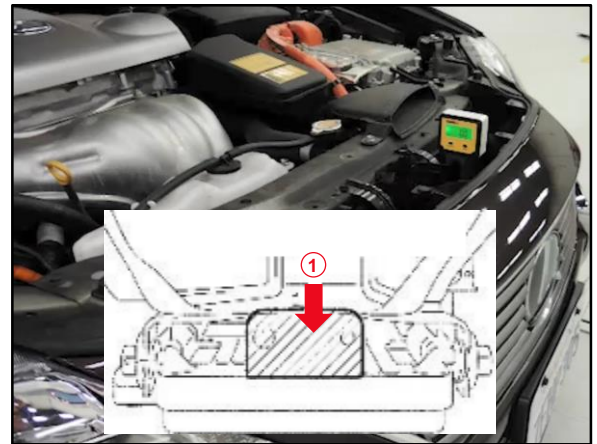

1 Calibration Surface

- C. Place the digital angle gauge on Attachment A with the screen facing the passenger side of the vehicle and retrieve the sensor angle.

NOTE

- The digital angle gauge is directional and **MUST** be placed with the screen facing the passenger side of the vehicle for the up/down indicator to properly display the angle of the radar sensor. The tool indicates a positive or negative angle based on the right side of the tool's vertical location.
- Once the digital angle gauge has been powered on, the unit must be set to Absolute Mode, ABS will be displayed in the upper right corner of the display.
- Refer to the instruction video link: [Digital Angle Gauge SST 01815-00102 Operation Overview.](#)

Figure 6. Digital Angle Gauge



1 ABS Is Displayed

Millimeter Wave Radar Sensor - Floor Slope Compensation

Floor Slope Compensation Procedure (continued)

- D. Adjust the radar vertical angle to the value calculated on the slope calculation sheet.

NOTE

When adjusting the vertical angle ensure you pay attention to the up/down indicators on both the slope calculation sheet AND the digital angle gauge.

Figure 7.

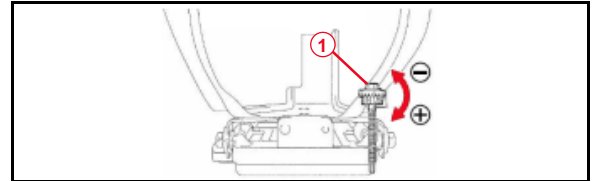

1	Bolt A
----------	---------------

- 7. Set the target placement and perform sensor calibration.
 - A. Locate and mark the center line of the vehicle.
 - B. Locate the reflector calibration position.

Figure 8.

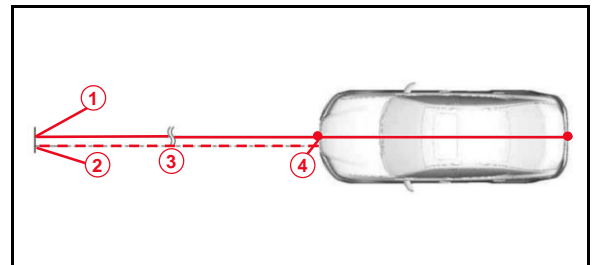

1	Mark Centerline
2	Electronic Tape Measure
3	5 m (16.4 ft.)
4	Millimeter Wave Radar Sensor Position

Millimeter Wave Radar Sensor - Floor Slope Compensation

Floor Slope Compensation Procedure (continued)

C. Set the reflector height.

NOTE

Refer to the instruction video link:
[Reflector C Placement and Height Adjustment Procedure.](#)

- (1) Place the tri-pod and laser level in front of the vehicle.
- (2) Level the tri-pod base and head using the built-in bubble levels.
- (3) Turn ON the laser level to the unlocked position with both the vertical AND horizontal laser lines being projected.
- (4) Adjust the height of the tri-pod head and laser until the laser line crosses the center of the front emblem as shown.

NOTE

The laser switch MUST be in the unlocked position so it can automatically self-level. If the laser light is flashing this indicates that the laser is NOT leveled or is in the locked position.

Figure 9.

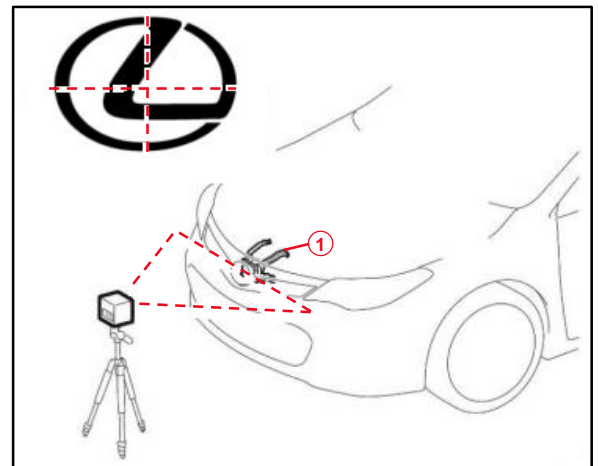

1 Millimeter Waver Radar Sensor Assembly

Millimeter Wave Radar Sensor - Floor Slope Compensation

Floor Slope Compensation Procedure (continued)

- (5) Turn the self-leveling laser 180° and toward the reflector stand.

NOTE

Do NOT change the height of the laser level or tripod when performing this step.

Figure 10.

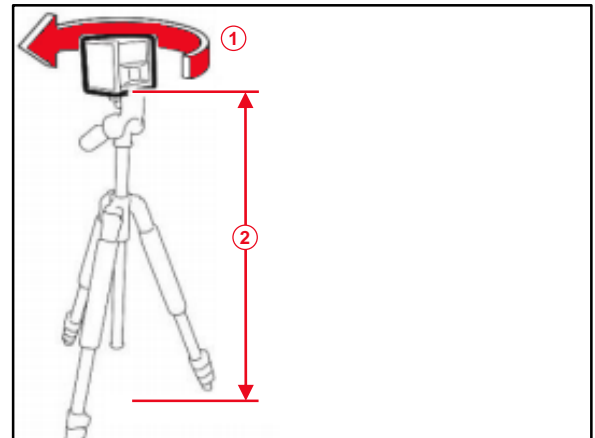

1	Turn the Self-leveling Laser 180°
2	Do Not Change the Height

- (6) Adjust the height of the reflector until the center aligns with the laser lines as shown.

Figure 11.

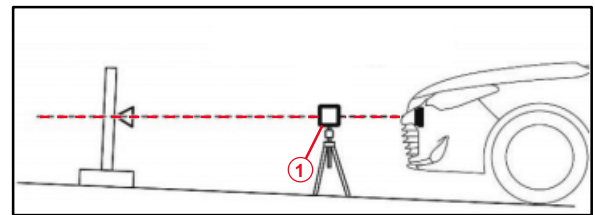

1	Self-leveling Laser
----------	---------------------

- (7) Adjust the height of the reflector up or down in accordance with the slope calculation sheet value.

Figure 12. Upward Slope Example

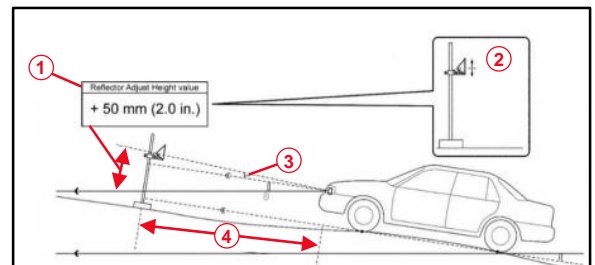

1	Value Shown in the Slope Calculation Sheet.
2	Reflector Height
3	0.2°
4	5 m (16.4 ft.)

8. Perform a beam axis adjustment of the millimeter wave radar sensor.