

DTC P0712 Transmission Fluid Temperature Sensor "A" Circuit Low Input

DTC P0713 Transmission Fluid Temperature Sensor "A" Circuit High Input

for Preparation [Click here](#)

DESCRIPTION

Refer to DTC P0711 ([Click here](#)).

DTC Code	DTC Detection Condition	Trouble Area
P0712	ATF temperature sensor resistance is below 79 Ω for 0.5 sec. or more (1-trip detection logic).	<ul style="list-style-type: none">• Short in ATF temperature sensor circuit• ATF temperature sensor (No. 1 ATF temperature sensor)• ECM
P0713	One of the following conditions is met (1-trip detection logic): (A) 15 min. or more have elapsed after the engine start when the engine coolant temperature or intake air temperature is -29.375°C (-20.875°F) or less, and the ATF temperature sensor resistance is higher than 156 k Ω for 0.5 sec. or more. (B) 10 sec. or more have elapsed after the engine start when the engine coolant temperature and intake air temperature are higher than -29.375°C (-20.875°F), and the ATF temperature sensor resistance is higher than 156 k Ω for 0.5 sec. or more.	<ul style="list-style-type: none">• Open in ATF temperature sensor circuit• ATF temperature sensor (No. 1 ATF temperature sensor)• ECM

MONITOR DESCRIPTION

The ATF temperature sensor converts the ATF temperature to an electrical resistance value. Based on the resistance, the ECM determines the ATF temperature and detects an open or short in the ATF temperature sensor circuit. If the resistance value of the ATF temperature sensor is below 79 Ω *1 or higher than 156 k Ω *2, the ECM interprets this as a fault in the ATF temperature sensor or wiring. The ECM will illuminate the MIL and store the DTC.

HINT:

- *1: 150°C (302°F) or higher is indicated regardless of the actual ATF temperature.
- *2: -40°C (-40°F) is indicated regardless of the actual ATF temperature.
- The ATF temperature can be checked on the tester display.

WIRING DIAGRAM

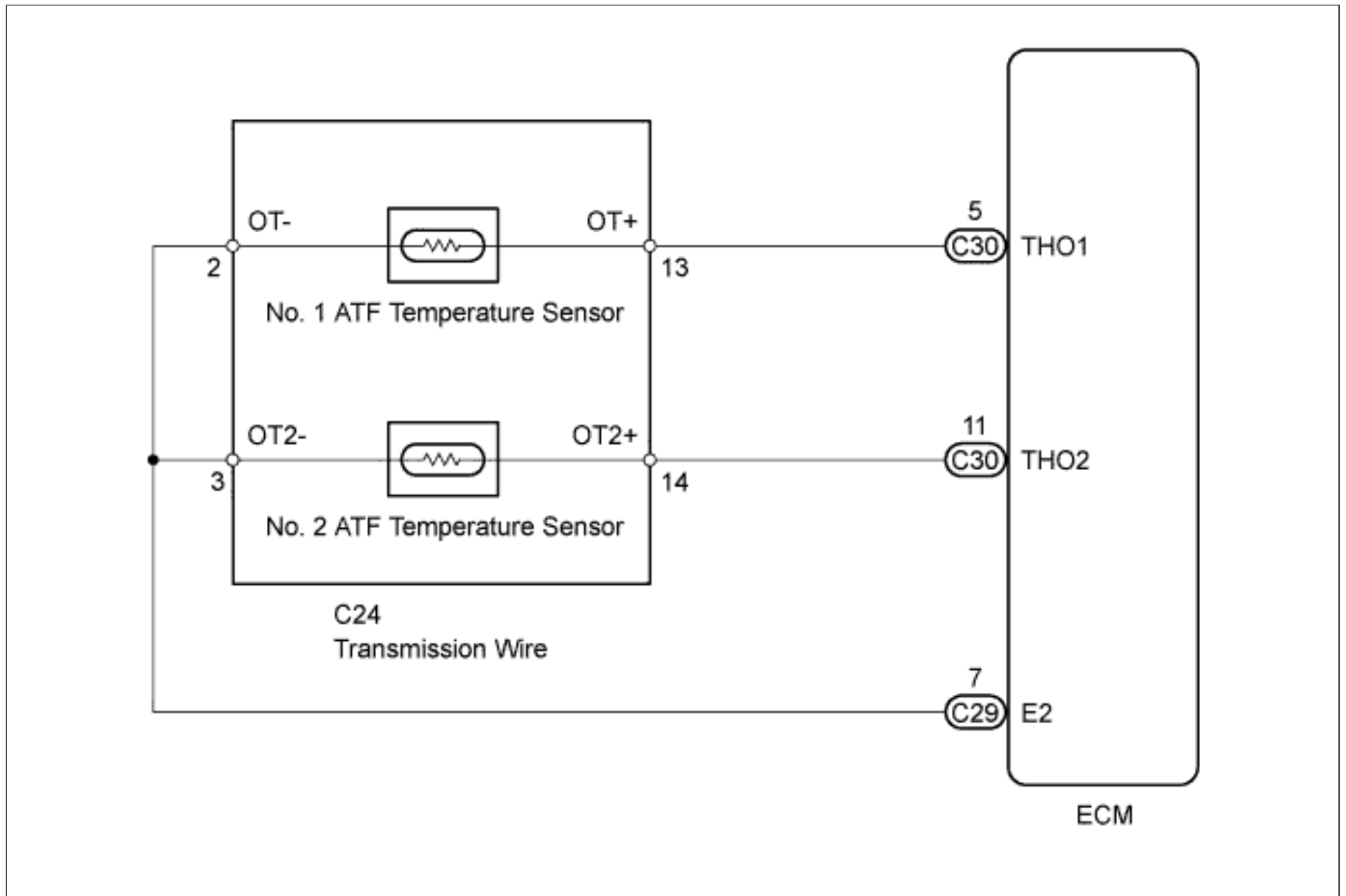

INSPECTION PROCEDURE

DATA LIST

HINT:

Using the intelligent tester to read the Data List allows the values or states of switches, sensors, actuators and other items to be read without removing any parts. This non-intrusive inspection can be very useful because intermittent conditions or signals may be discovered before parts or wiring is disturbed. Reading the Data List information early in troubleshooting is one way to save diagnostic time.

NOTICE:

In the table below, the values listed under "Normal Condition" are reference values. Do not depend solely on these reference values when deciding whether a part is faulty or not.

- a. Warm up the engine.
- b. Turn the engine switch off.
- c. Connect the intelligent tester to the DLC3.
- d. Turn the engine switch on (IG).
- e. Turn the intelligent tester on.
- f. Enter the following menus: Powertrain / Engine and ECT / Data List.
- g. According to the display on the tester, read the Data List.

Engine and ECT

Tester Display	Measurement Item/Range	Normal Condition	Diagnostic Note
A/T Oil Temperature 1	No. 1 ATF temperature sensor value/ Min.: -40°C (-40°F) Max.: 215°C (419°F)	<ul style="list-style-type: none"> • After stall test: Approximately 80°C (176°F) • Equal to ambient temperature when engine cold 	If the value is -40°C (-40°F) or 215°C (419°F), the No. 1 ATF temperature sensor circuit is open or shorted.

HINT:

When DTC P0712 is output and the intelligent tester output is 150°C (302°F) or higher, there is a short circuit.

When DTC P0713 is output and the intelligent tester output is -40°C (-40°F), there is an open circuit.

Check the temperature displayed on the tester in order to check if a malfunction exists.

Temperature Displayed	Malfunction
-40°C (-40°F)	Open circuit
150°C (302°F) or higher	Short circuit

If a circuit related to the ATF temperature sensor becomes open, P0713 is immediately stored (in 0.5 seconds). When P0713 is stored, P0711 cannot be stored. It is not necessary to inspect the circuit when P0711 is stored.

1.INSPECT TRANSMISSION WIRE (NO. 1 ATF TEMPERATURE SENSOR)

- a. Disconnect the C24 transmission wire connector.
- b. Measure the resistance according to the value(s) in the table below.

Standard Resistance:

Tester Connection	Condition	Specified Condition
2 (OT-) - 13 (OT+)	Always	79 Ω to 156 kΩ
2 (OT-) - Body ground	Always	10 kΩ or higher
13 (OT+) - Body ground	Always	10 kΩ or higher

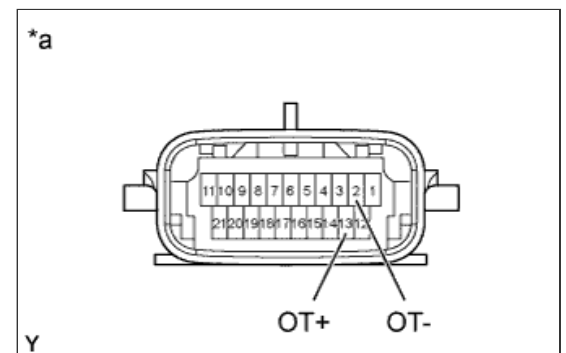

HINT:

If the resistance is out of the specified range at any of the ATF temperatures shown in the table below, the driveability of the vehicle may decrease.

Standard Resistance:

ATF Temperature	Specified Condition
10°C (50°F)	5 to 8 kΩ
25°C (77°F)	2.5 to 4.5 kΩ
110°C (230°F)	0.22 to 0.28 kΩ

Text in Illustration

*a	Component without harness connected (Transmission Wire)
----	---

NG

REPAIR OR REPLACE TRANSMISSION WIRE (NO. 1 ATF TEMPERATURE SENSOR) ([Click here](#))

OK

2.CHECK HARNESS AND CONNECTOR (TRANSMISSION WIRE - ECM)

- a. Disconnect the C29 and C30 ECM connectors.
- b. Measure the resistance according to the value(s) in the table below.

Standard Resistance:

Tester Connection	Condition	Specified Condition
C30-5 (THO1) - C29-7 (E2)	Always	79 Ω to 156 kΩ
C30-5 (THO1) - Body ground	Always	10 kΩ or higher
C29-7 (E2) - Body ground	Always	10 kΩ or higher

Text in Illustration

*a	Front view of wire harness connector (to ECM)
----	---

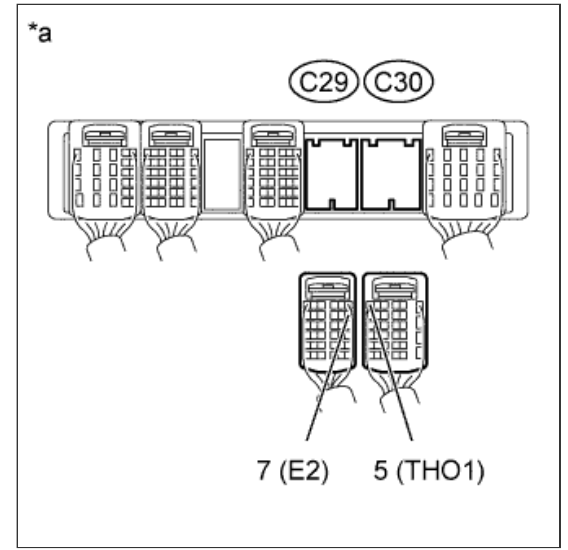

NG

REPAIR OR REPLACE HARNESS OR CONNECTOR

OK

REPLACE ECM ([Click here](#))