

DTC P0894 Transmission Component Slipping

DTC P2714 Pressure Control Solenoid "D" Performance (Shift Solenoid Valve SLT)

for Preparation [Click here](#)

DESCRIPTION

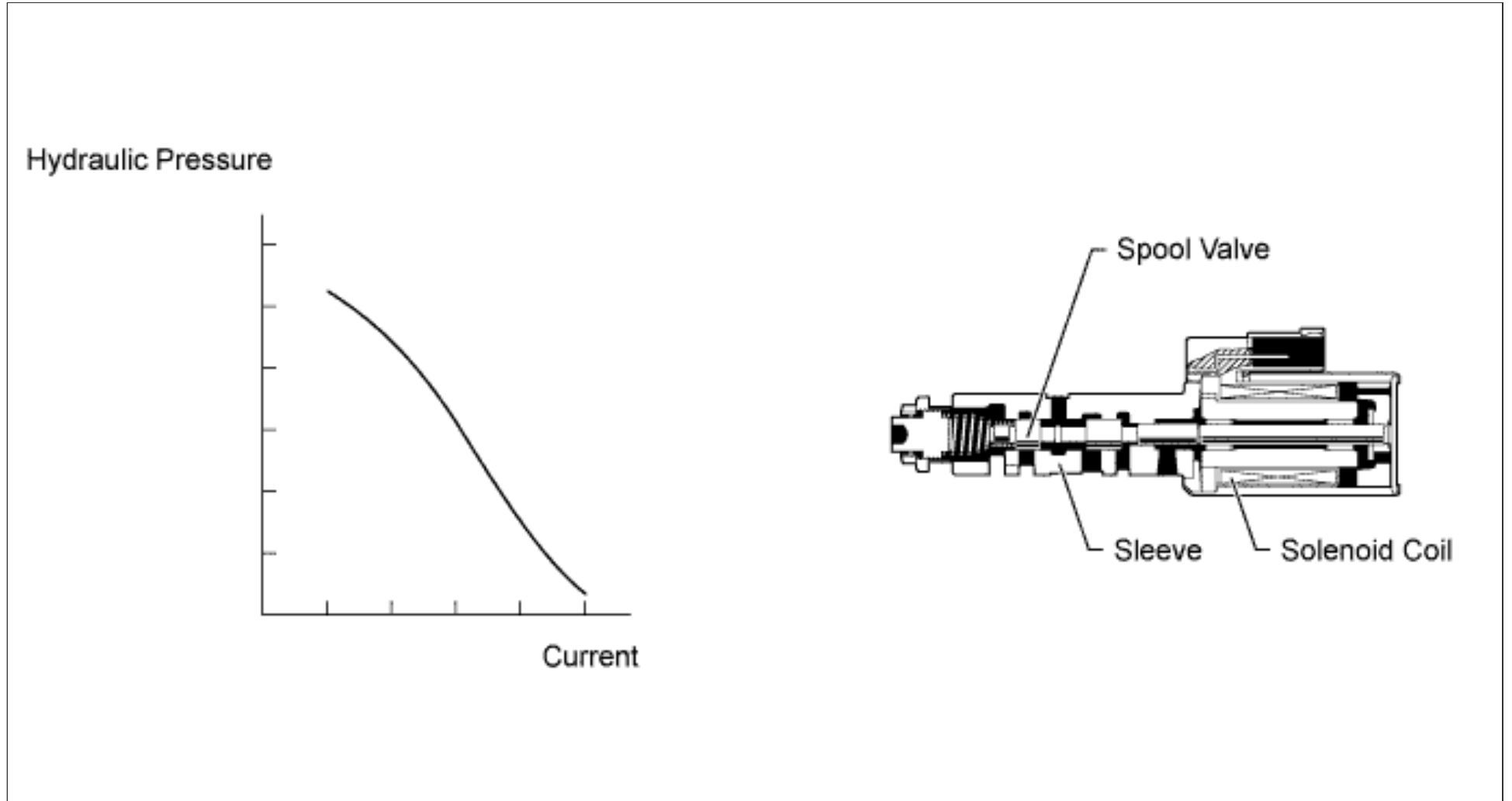

Shift solenoid valve SLT controls the transmission line pressure for smooth transmission operation based on signals from the throttle position sensor and vehicle speed sensor. The ECM adjusts the current to shift solenoid valve SLT to control the hydraulic line pressure coming from the primary regulator valve. Appropriate line pressure assures smooth shifting with varying engine outputs.

DTC Code	DTC Detection Condition	Trouble Area
P0894	The ECM detects a malfunction in shift solenoid valve SLT, S1, S2, S3, S4 or SL2, or the 1-2 shift valve, or an incorrect gear 6 ratio according to the difference in speed of the turbine and output shaft, and also by the oil pressure (2-trip detection logic).	<ul style="list-style-type: none">• Shift solenoid valve SLT remains open or closed• Shift solenoid valve S1, S2, S3, S4 or SL2 remains open or closed• Gear 6 incorrect ratio (sequence valve) or 1-2 shift valve is stuck• Valve body is blocked• Automatic transmission (clutch, brake, gear, etc.)
P2714	The ECM detects a malfunction in shift solenoid valve SLT (ON side) according to the difference in speed of the turbine and output shaft, and also by the oil pressure (2-trip detection logic*1, 1-trip detection logic*2).	<ul style="list-style-type: none">• Shift solenoid valve SLT remains open or closed• Shift solenoid valve S1, S2, S3, S4 or SL2 remains open or closed• Gear 6 incorrect ratio (sequence valve) or 1-2 shift valve is stuck• Valve body is blocked• Automatic transmission (clutch, brake, gear, etc.)

*1: w/ OBD

*2: w/o OBD

MONITOR DESCRIPTION

The ECM calculates the amount of heat absorbed by the friction material based on the difference in speed (clutch slippage) between the turbine and output shaft. The ECM illuminates the MIL and stores this DTC when the amount of heat absorption exceeds the specified value. There are two causes of speed difference.

- When shift solenoid valve SLT remains ON, oil pressure decreases, which causes the clutch engagement force to decrease.
- When a shift solenoid valve remains ON or OFF, the gear position commanded by the ECM and the actual gear position are not the same.

NOTICE:

If you continue driving under these conditions, the clutch will burn out and the vehicle will no longer be drivable.

INSPECTION PROCEDURE

1.CHECK DTC OUTPUT (IN ADDITION TO DTCS P0894 AND P2714)

- a. Connect the intelligent tester to the DLC3.
- b. Turn the engine switch on (IG).

- c. Turn the intelligent tester on.
- d. Enter the following menus: Powertrain / Engine and ECT / DTC.
- e. Read the DTCs using the tester.

Result

Result	Proceed to
<ul style="list-style-type: none"> • Only P0894 is output • Only P0894 and P2714 are output 	A
P0894, P2714 and other DTCs are output	B

HINT:

If any other codes besides P0894 and P2714 are output, perform troubleshooting for those DTCs first.

B GO TO DTC CHART ([Click here](#))

A

2.PERFORM ACTIVE TEST USING INTELLIGENT TESTER (SHIFT SOLENOID VALVE SLT)

NOTICE:

- Perform the test while the ATF temperature is between 50 and 80°C (122 and 176°F).
- Be careful to prevent the hose of SST from interfering with the exhaust pipe.
- Perform the test with the A/C off.

HINT:

Using the intelligent tester to perform Active Tests allows relays, VSVs, actuators and other items to be operated without removing any parts. This non-intrusive functional inspection can be very useful because intermittent operation may be discovered before parts or wiring is disturbed. Performing Active Tests early in troubleshooting is one way to save diagnostic time. Data List information can be displayed while performing Active Tests.

- a. Remove the test plug from the transmission case and connect SST.

SST
09992-00095 (09992-00231, 09992-00271)

- b. Connect the intelligent tester to the DLC3.
- c. Start the engine and warm it up.
- d. Measure the line pressure with SST.
- e. Turn the intelligent tester on.
- f. Enter the following menus: Powertrain / Engine and ECT / Active Test.
- g. According to the display on the tester, perform the Active Test.
- h. Measure the line pressure.

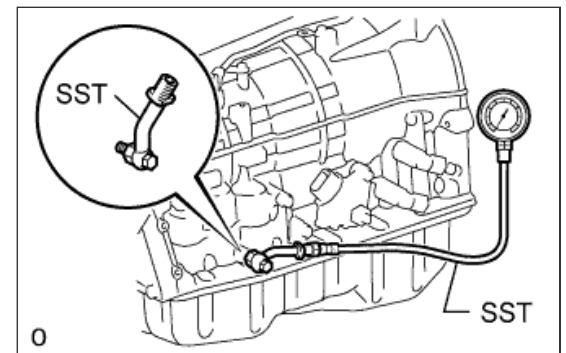

Engine and ECT

Tester Display	Test Part	Control Range	Diagnostic Note
Activate the Solenoid (SLT)*	Operate shift solenoid valve SLT and raise line pressure	ON or OFF HINT: <ul style="list-style-type: none"> • OFF: Line pressure up (when Active Test "Activate the Solenoid (SLT)" performed, ECM commands shift solenoid valve SLT to turn off) • ON: No action (normal operation) 	[Vehicle Condition] <ul style="list-style-type: none"> • Vehicle stopped • Engine idling

HINT:

*: Activate the Solenoid (SLT) in the Active Test is performed to check the line pressure changes by connecting SST to the automatic transmission, which is used in the Hydraulic Test ([Click here](#)) as well. Note that the pressure values in the Active Test and Hydraulic Test are different.

OK:

The line pressure changes as specified when performing the Active Test.

NG Go to step 7

OK

3.PERFORM ACTIVE TEST USING INTELLIGENT TESTER (RUNNING TEST)

CAUTION:

This test should always be performed with at least 2 people.

NOTICE:

- Perform the test while the ATF temperature is between 50 and 80°C (122 and 176°F).
- Perform the test with the A/C turned off.

HINT:

Using the intelligent tester to perform Active Tests allows relays, VSVs, actuators and other items to be operated without removing any parts. This non-intrusive functional inspection can be very useful because intermittent operation may be discovered before parts or wiring is disturbed. Performing Active Tests early in troubleshooting is one way to save diagnostic time. Data List information can be displayed while performing Active Tests.

- Connect the intelligent tester to the DLC3.
- Clear the DTC ([Click here](#)).
- Enter the following menus: Powertrain / Engine and ECT / Active Test.
- According to the display on the tester, perform the Active Test.

HINT:

While driving, the shift position can be forcibly changed with the intelligent tester.

Engine and ECT

Tester Display	Test Part	Control Range	Diagnostic Note
Control the Shift Position	Operate shift solenoid valves and set each shift position	<ul style="list-style-type: none"> • Press "→" button: Shift up • Press "←" button: Shift down 	Possible to check operation of the shift solenoid valves. [Vehicle Condition] 50 km/h (30 mph) or less

HINT:

- This test can be conducted when the vehicle speed is 50 km/h (30 mph) or less.
- The 4th to 5th and 5th to 6th up-shifts must be performed with the accelerator pedal released.
- The 6th to 5th and 5th to 4th down-shifts must be performed with the accelerator pedal released.
- Do not operate the accelerator pedal for at least 2 seconds after shifting and do not shift successively.
- The shift position commanded by the ECM is shown in the Data List display on the tester.

- Compare the ECM gear shift command and the actual gear position.

Result

ECM Gear Shift Command		1st	2nd	3rd	4th	5th	6th	Proceed to	
Actual gear position under malfunction	Shift solenoid S1	Stuck ON*1	2nd	2nd	3rd	4th	5th	A	
		Stuck OFF	1st	1st	3rd	4th	5th		N*2
	Shift solenoid S2	Stuck ON	1st	2nd	2nd	4th	6th	6th	B
		Stuck OFF	3rd	3rd	3rd	4th	5th	5th	
	Shift solenoid S3	Stuck ON	1st	2nd	3rd	3rd	N*2	N*2	C
		Stuck OFF	3rd	4th	4th	4th	5th	6th	
	Shift solenoid S4	Stuck ON*3	1st	2nd	3rd	4th	5th	6th	D
		Stuck OFF	1st	2nd	3rd	4th	4th	4th	
Actual gear position when normal		1st	2nd	3rd	4th	5th	6th	E	

HINT:

- *1: When shift solenoid S1 is stuck ON, the vehicle cannot drive in reverse.
- *2: Neutral
- *3: When shift solenoid S4 is stuck ON, gear shifting is normal.

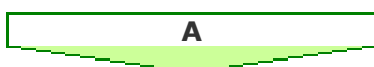
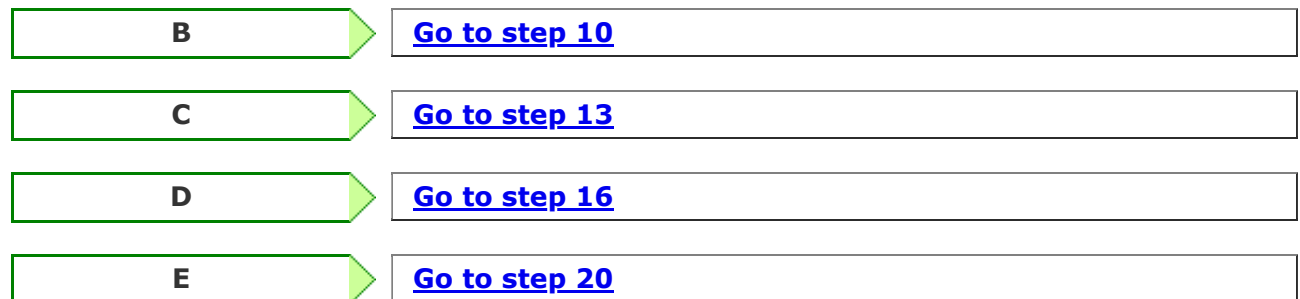

4.INSPECT SHIFT SOLENOID VALVE S1

- Remove shift solenoid valve S1.
- Measure the resistance according to the value(s) in the table below.

Standard Resistance:

Tester Connection	Condition	Specified Condition
Shift solenoid valve S1 connector terminal - Shift solenoid valve S1 body	20°C (68°F)	11 to 15 Ω

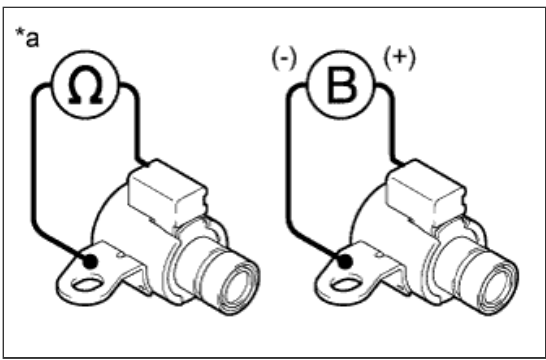

c. Apply 12 V battery voltage to the shift solenoid valve and check that the valve moves and makes an operating noise.

OK:

Measurement Condition	Specified Condition
<ul style="list-style-type: none"> Battery positive (+) → Shift solenoid valve S1 connector Battery negative (-) → Shift solenoid valve S1 body 	Valve moves and makes an operating noise

Text in Illustration

*a	Component without harness connected (Shift Solenoid Valve S1)
----	---

NG

REPLACE SHIFT SOLENOID VALVE S1 ([Click here](#))

OK

5.INSPECT TRANSMISSION VALVE BODY ASSEMBLY

a. Check the transmission valve body assembly.

OK:

There are no foreign objects on each valve.

NG

REPAIR OR REPLACE TRANSMISSION VALVE BODY ASSEMBLY ([Click here](#))

OK

6.INSPECT TORQUE CONVERTER CLUTCH ASSEMBLY

a. Check the torque converter clutch assembly ([Click here](#)).

OK:

The torque converter clutch operates normally.

NG

REPLACE TORQUE CONVERTER CLUTCH ASSEMBLY ([Click here](#))

OK

REPAIR OR REPLACE AUTOMATIC TRANSMISSION ASSEMBLY ([Click here](#))

7.INSPECT SHIFT SOLENOID VALVE SLT

a. Remove shift solenoid valve SLT.

b. Measure the resistance according to the value(s) in the table below.

Standard Resistance:

Tester Connection	Condition	Specified Condition
1 - 2	20°C (68°F)	5.0 to 5.6 Ω

c. Apply 12 V battery voltage to the shift solenoid valve and check that the valve moves and makes an operating noise.

OK:

Measurement Condition	Specified Condition
<ul style="list-style-type: none"> Battery positive (+) with a 21 W bulb → Terminal 2 Battery negative (-) → Terminal 1 	Valve moves and makes an operating noise

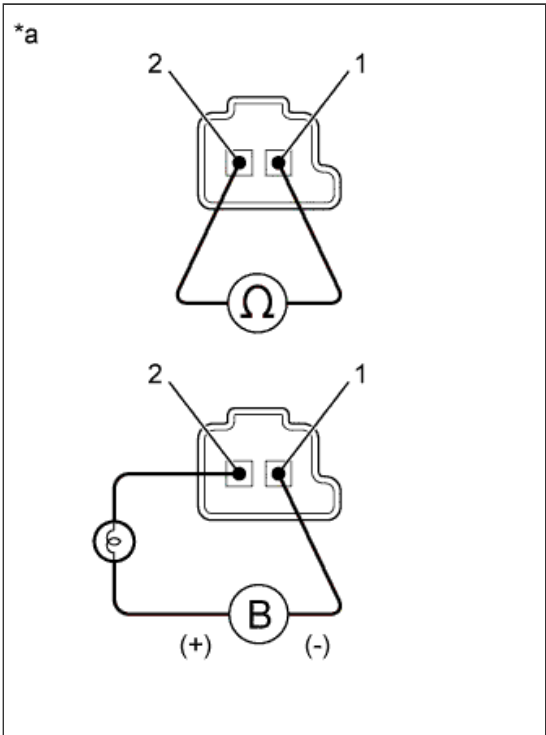

Text in Illustration

*a Component without harness connected (Shift Solenoid Valve SLT)

NG

REPLACE SHIFT SOLENOID VALVE SLT ([Click here](#))

OK

8.INSPECT TRANSMISSION VALVE BODY ASSEMBLY

a. Check the transmission valve body assembly.

OK:
There are no foreign objects on each valve.

NG

REPAIR OR REPLACE TRANSMISSION VALVE BODY ASSEMBLY ([Click here](#))

OK

9.INSPECT TORQUE CONVERTER CLUTCH ASSEMBLY

a. Check the torque converter clutch assembly ([Click here](#)).

OK:
The torque converter clutch operates normally.

NG

REPLACE TORQUE CONVERTER CLUTCH ASSEMBLY ([Click here](#))

OK

REPAIR OR REPLACE AUTOMATIC TRANSMISSION ASSEMBLY ([Click here](#))

10.INSPECT SHIFT SOLENOID VALVE S2

- a. Remove shift solenoid valve S2.
- b. Measure the resistance according to the value(s) in the table below.

Standard Resistance:

Tester Connection	Condition	Specified Condition
Shift solenoid valve S2 connector terminal - Shift solenoid valve S2 body	20°C (68°F)	11 to 15 Ω

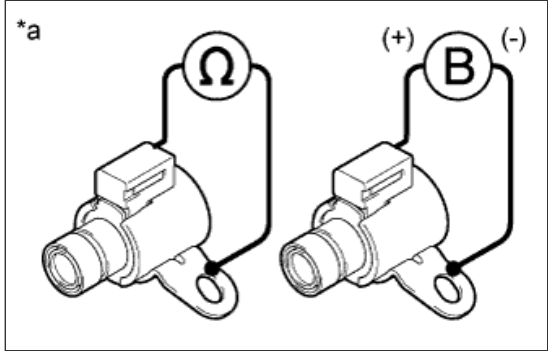

c. Apply 12 V battery voltage to the shift solenoid valve and check that the valve moves and makes an operating noise.

OK:

Measurement Condition	Specified Condition
<ul style="list-style-type: none"> • Battery positive (+) → Shift solenoid valve S2 connector • Battery negative (-) → Shift solenoid valve S2 body 	Valve moves and makes an operating noise

Text in Illustration

*a Component without harness connected (Shift Solenoid Valve S2)

NG

REPLACE SHIFT SOLENOID VALVE S2 ([Click here](#))

OK

11.INSPECT TRANSMISSION VALVE BODY ASSEMBLY

a. Check the transmission valve body assembly.

OK:
There are no foreign objects on each valve.

NG

REPAIR OR REPLACE TRANSMISSION VALVE BODY ASSEMBLY ([Click here](#))

OK

12.INSPECT TORQUE CONVERTER CLUTCH ASSEMBLY

- a. Check the torque converter clutch assembly ([Click here](#)).

OK:
The torque converter clutch operates normally.

NG

REPLACE TORQUE CONVERTER CLUTCH ASSEMBLY ([Click here](#))

OK

REPAIR OR REPLACE AUTOMATIC TRANSMISSION ASSEMBLY ([Click here](#))

13.INSPECT SHIFT SOLENOID VALVE S3

- a. Remove shift solenoid valve S3.
- b. Measure the resistance according to the value(s) in the table below.

Standard Resistance:

Tester Connection	Condition	Specified Condition
Shift solenoid valve S3 connector terminal - Shift solenoid valve S3 body	20°C (68°F)	11 to 15 Ω

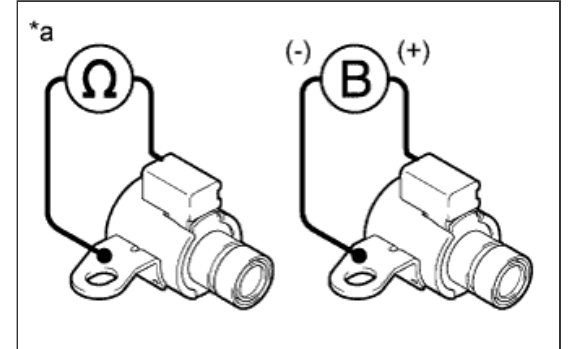

- c. Apply 12 V battery voltage to the shift solenoid valve and check that the valve moves and makes an operating noise.

OK:

Measurement Condition	Specified Condition
<ul style="list-style-type: none"> Battery positive (+) → Shift solenoid valve S3 connector Battery negative (-) → Shift solenoid valve S3 body 	Valve moves and makes an operating noise

Text in Illustration

*a	Component without harness connected (Shift Solenoid Valve S3)
----	---

NG

REPLACE SHIFT SOLENOID VALVE S3 ([Click here](#))

OK

14.INSPECT TRANSMISSION VALVE BODY ASSEMBLY

- a. Check the transmission valve body assembly.

OK:
There are no foreign objects on each valve.

NG

REPAIR OR REPLACE TRANSMISSION VALVE BODY ASSEMBLY ([Click here](#))

OK

15.INSPECT TORQUE CONVERTER CLUTCH ASSEMBLY

- a. Check the torque converter clutch assembly ([Click here](#)).

OK:
The torque converter clutch operates normally.

NG

REPLACE TORQUE CONVERTER CLUTCH ASSEMBLY ([Click here](#))

OK

REPAIR OR REPLACE AUTOMATIC TRANSMISSION ASSEMBLY ([Click here](#))

16.INSPECT SHIFT SOLENOID VALVE S4

- a. Remove shift solenoid valve S4.
- b. Measure the resistance according to the value(s) in the table below.

Standard Resistance:

Tester Connection	Condition	Specified Condition
Shift solenoid valve S4 connector terminal - Shift solenoid valve S4 body	20°C (68°F)	11 to 15 Ω

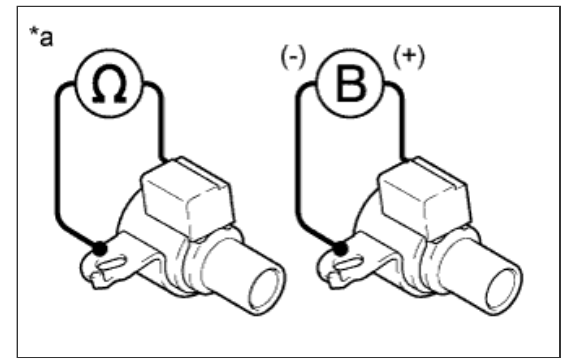

- c. Apply 12 V battery voltage to the shift solenoid valve and check that the valve moves and makes an operating noise.

OK:

Measurement Condition	Specified Condition
<ul style="list-style-type: none"> • Battery positive (+) → Shift solenoid valve S4 connector • Battery negative (-) → Shift solenoid valve S4 body 	Valve moves and makes an operating noise

Text in Illustration

*a	Component without harness connected (Shift Solenoid Valve S4)
----	---

NG

REPLACE SHIFT SOLENOID VALVE S4 ([Click here](#))

OK

17.INSPECT SHIFT SOLENOID VALVE SL2

- a. Remove shift solenoid valve SL2.
- b. Measure the resistance according to the value(s) in the table below.

Standard Resistance:

Tester Connection	Condition	Specified Condition
1 - 2	20°C (68°F)	5.0 to 5.6 Ω

- c. Apply 12 V battery voltage to the shift solenoid valve and check that the valve moves and makes an operating noise.

OK:

Measurement Condition	Specified Condition
<ul style="list-style-type: none"> • Battery positive (+) with a 21 W bulb → Terminal 1 • Battery negative (-) → Terminal 2 	Valve moves and makes an operating noise

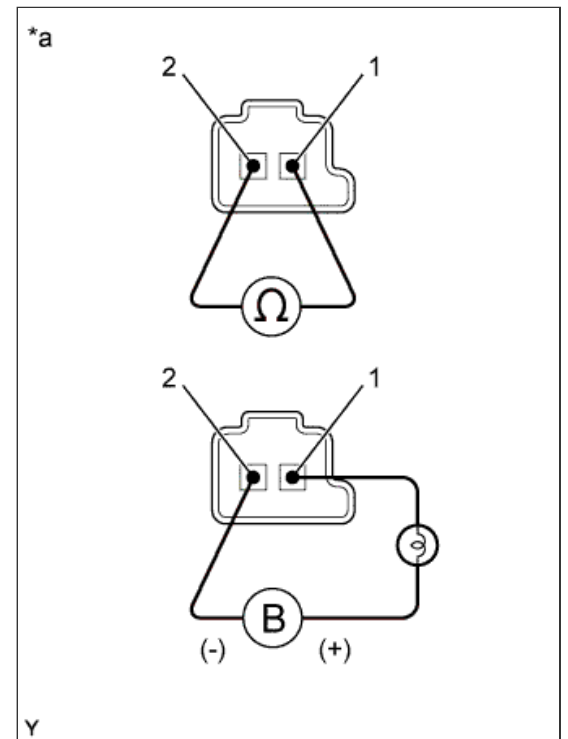

Text in Illustration

*a	Component without harness connected (Shift Solenoid Valve SL2)
----	--

NG

REPLACE SHIFT SOLENOID VALVE SL2 ([Click here](#))

OK

18.INSPECT TRANSMISSION VALVE BODY ASSEMBLY

- a. Check the transmission valve body assembly.

OK:

There are no foreign objects on each valve.

NG

REPAIR OR REPLACE TRANSMISSION VALVE BODY ASSEMBLY ([Click here](#))

OK

19.INSPECT TORQUE CONVERTER CLUTCH ASSEMBLY

- a. Check the torque converter clutch assembly ([Click here](#)).

OK:
The torque converter clutch operates normally.

NG

REPLACE TORQUE CONVERTER CLUTCH ASSEMBLY ([Click here](#))

OK

REPAIR OR REPLACE AUTOMATIC TRANSMISSION ASSEMBLY ([Click here](#))

20.INSPECT SHIFT SOLENOID VALVE SLT

- a. Remove shift solenoid valve SLT.
b. Measure the resistance according to the value(s) in the table below.

Standard Resistance:

Tester Connection	Condition	Specified Condition
1 - 2	20°C (68°F)	5.0 to 5.6 Ω

- c. Apply 12 V battery voltage to the shift solenoid valve and check that the valve moves and makes an operating noise.

OK:

Measurement Condition	Specified Condition
<ul style="list-style-type: none"> Battery positive (+) with a 21 W bulb → Terminal 2 Battery negative (-) → Terminal 1 	Valve moves and makes an operating noise

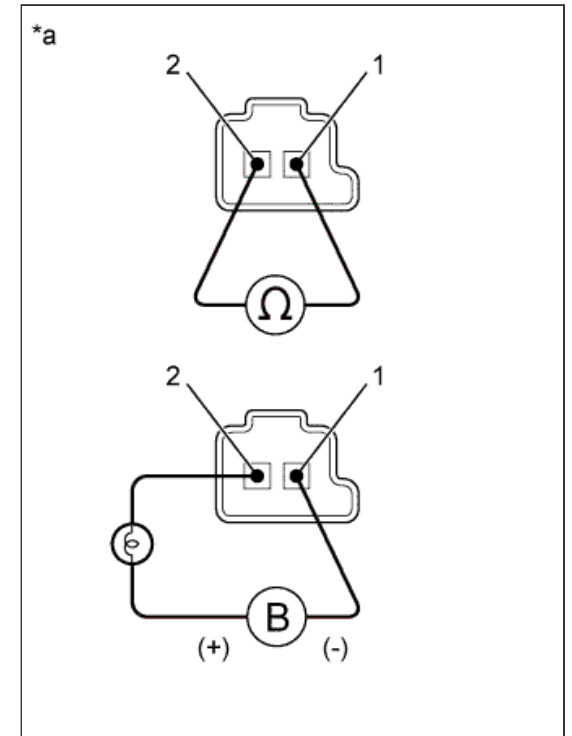

Text in Illustration

*a	Component without harness connected (Shift Solenoid Valve SLT)
----	--

NG

REPLACE SHIFT SOLENOID VALVE SLT ([Click here](#))

OK

21.INSPECT TRANSMISSION VALVE BODY ASSEMBLY

- a. Check the transmission valve body assembly.

OK:
There are no foreign objects on each valve.

NG

REPAIR OR REPLACE TRANSMISSION VALVE BODY ASSEMBLY ([Click here](#))

OK

22.INSPECT TORQUE CONVERTER CLUTCH ASSEMBLY

- a. Check the torque converter clutch assembly ([Click here](#)).

OK:
The torque converter clutch operates normally.

NG

REPLACE TORQUE CONVERTER CLUTCH ASSEMBLY ([Click here](#))

OK

REPAIR OR REPLACE AUTOMATIC TRANSMISSION ASSEMBLY ([Click here](#))

