

DTC P0973 Shift Solenoid "A" Control Circuit Low (Shift Solenoid Valve S1)

DTC P0974 Shift Solenoid "A" Control Circuit High (Shift Solenoid Valve S1)

for Preparation [Click here](#)

DESCRIPTION

Shifting from 1st to 6th is performed in combination with the ON and OFF operation of shift solenoid valves SL1, SL2, S1, S2, S3, S4 and SR, which are controlled by the ECM. If an open or short circuit occurs in any of the shift solenoid valves, the ECM controls the remaining normal shift solenoid valves to allow the vehicle to be operated safely. Also, the ECM stops sending current to the open or short-circuited solenoid ([Click here](#)).

DTC Code	DTC Detection Condition	Trouble Area
P0973	ECM detects a short in the solenoid valve S1 circuit 2 times when solenoid valve S1 is operated (1-trip detection logic).	<ul style="list-style-type: none"> Short in shift solenoid valve S1 circuit Shift solenoid valve S1 ECM
P0974	ECM detects an open in the solenoid valve S1 circuit 2 times when solenoid valve S1 is not operated (1-trip detection logic).	<ul style="list-style-type: none"> Open in shift solenoid valve S1 circuit Shift solenoid valve S1 ECM

MONITOR DESCRIPTION

These DTCs indicate an open or short in the shift solenoid valve S1 circuit. When there is an open or short circuit in any shift solenoid valve circuit, the ECM detects the problem, illuminates the MIL and stores the DTC. When shift solenoid valve S1 is ON, if its resistance is 8 Ω or less, the ECM determines there is a short in the shift solenoid valve S1 circuit. When shift solenoid valve S1 is OFF, if its resistance is 100 kΩ or higher, the ECM determines there is an open in the shift solenoid valve S1 circuit ([Click here](#)).

WIRING DIAGRAM

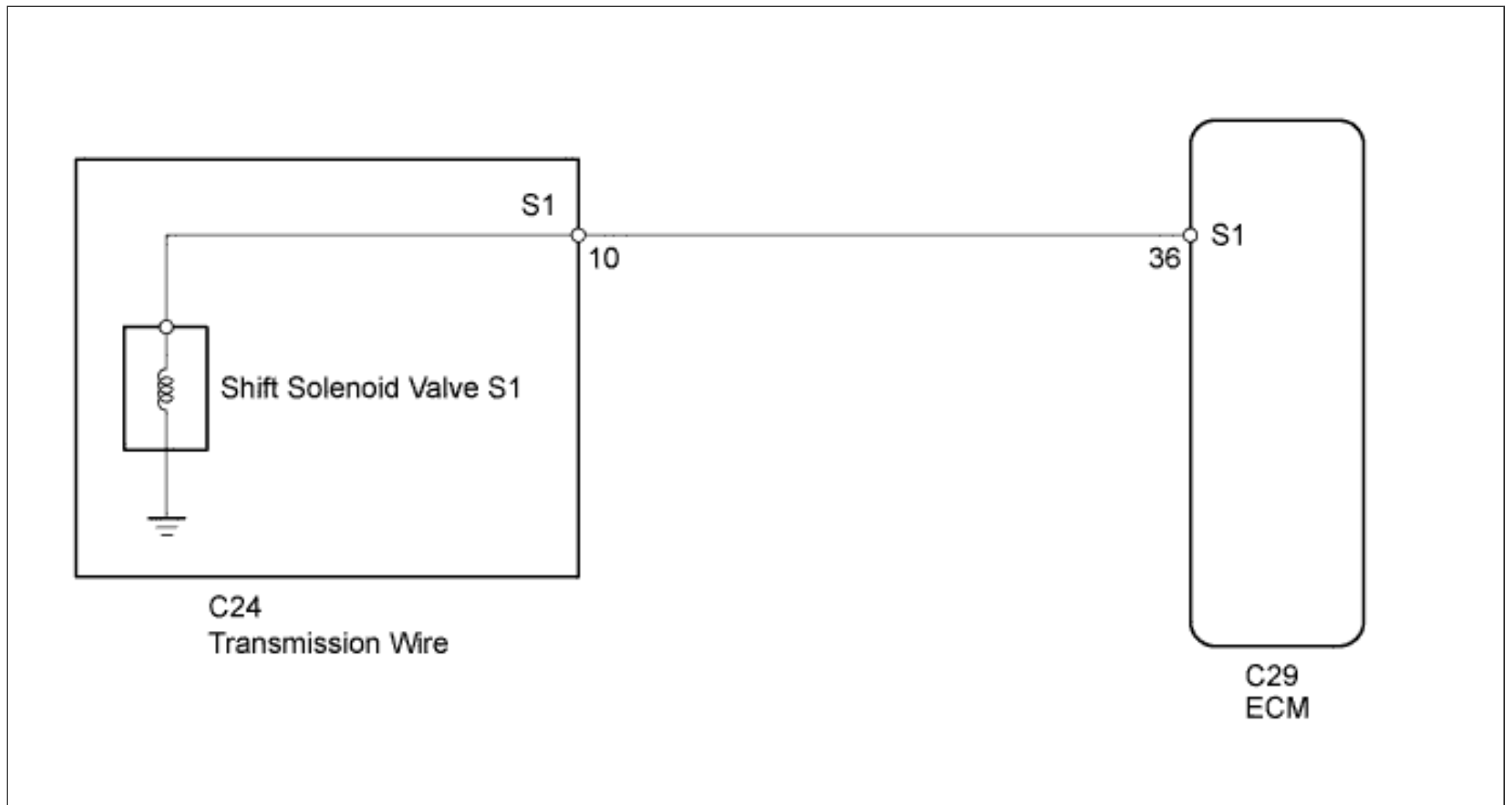

INSPECTION PROCEDURE

HINT:

Shift solenoid valve S1 is turned ON/OFF normally when the shift lever is in D:

ECM gear shift command	1st	2nd	3rd	4th	5th	6th
Shift solenoid valve S1	OFF	ON	ON	ON	ON	ON

1.INSPECT TRANSMISSION WIRE (SHIFT SOLENOID VALVE S1)

- a. Disconnect the C24 transmission wire connector.
- b. Measure the resistance according to the value(s) in the table below.

Standard Resistance:

--	--	--

Tester Connection	Condition	Specified Condition
10 (S1) - Body ground	20°C (68°F)	11 to 15 Ω

Text in Illustration

*a	Component without harness connected (Transmission Wire)
----	---

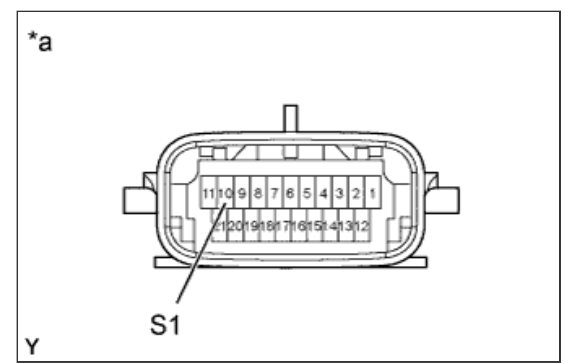

NG

[Go to step 3](#)

OK

2.CHECK HARNESS AND CONNECTOR (TRANSMISSION WIRE - ECM)

- a. Disconnect the C29 ECM connector.
- b. Measure the resistance according to the value(s) in the table below.

Standard Resistance:

Tester Connection	Condition	Specified Condition
C29-36 (S1) - Body ground	20°C (68°F)	11 to 15 Ω

Text in Illustration

*a	Front view of wire harness connector (to ECM)
----	---

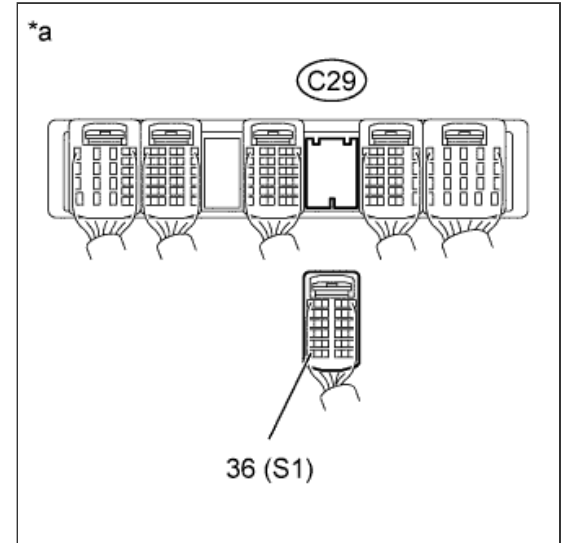

NG

REPAIR OR REPLACE HARNESS OR CONNECTOR

OK

REPLACE ECM ([Click here](#))

3.INSPECT SHIFT SOLENOID VALVE S1

- a. Remove shift solenoid valve S1.
- b. Measure the resistance according to the value(s) in the table below.

Standard Resistance:

Tester Connection	Condition	Specified Condition
Shift solenoid valve S1 connector terminal - Shift solenoid valve S1 body	20°C (68°F)	11 to 15 Ω

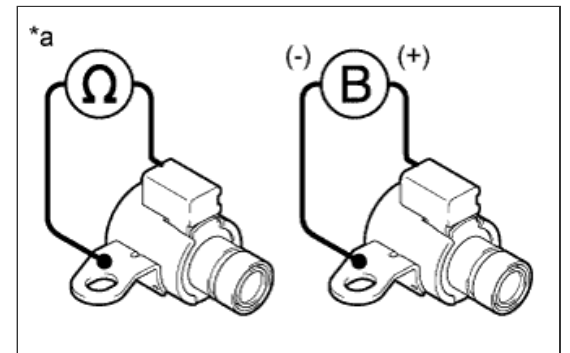

- c. Apply 12 V battery voltage to the shift solenoid valve and check that the valve moves and makes an operating noise.

OK:

Measurement Condition	Specified Condition
<ul style="list-style-type: none"> Battery positive (+) → Shift solenoid valve S1 connector Battery negative (-) → Shift solenoid valve S1 body 	Valve moves and makes an operating noise

Text in Illustration

*a	Component without harness connected (Shift Solenoid Valve S1)
----	---

NG

REPLACE SHIFT SOLENOID VALVE S1 ([Click here](#))

OK

REPAIR OR REPLACE TRANSMISSION WIRE ([Click here](#))

