

**DTC P0976 Shift Solenoid "B" Control Circuit Low (Shift Solenoid Valve S2)**

**DTC P0977 Shift Solenoid "B" Control Circuit High (Shift Solenoid Valve S2)**

for Preparation [Click here](#)

**DESCRIPTION**

Shifting from 1st to 6th is performed in combination with the ON and OFF operation of shift solenoid valves SL1, SL2, S1, S2, S3, S4 and SR, which are controlled by the ECM. If an open or short circuit occurs in any of the shift solenoid valves, the ECM controls the remaining normal shift solenoid valves to allow the vehicle to be operated safely. Also, the ECM stops sending current to the open or short-circuited solenoid ([Click here](#)).

DTC Code	DTC Detection Condition	Trouble Area
P0976	ECM detects a short in the solenoid valve S2 circuit 2 times when solenoid valve S2 is operated (1-trip detection logic).	<ul style="list-style-type: none"> <li>Short in shift solenoid valve S2 circuit</li> <li>Shift solenoid valve S2</li> <li>ECM</li> </ul>
P0977	ECM detects an open in the solenoid valve S2 circuit 2 times when solenoid valve S2 is not operated (1-trip detection logic).	<ul style="list-style-type: none"> <li>Open in shift solenoid valve S2 circuit</li> <li>Shift solenoid valve S2</li> <li>ECM</li> </ul>

**MONITOR DESCRIPTION**

These DTCs indicate an open or short in the shift solenoid valve S2 circuit. When there is an open or short circuit in any shift solenoid valve circuit, the ECM detects the problem, illuminates the MIL and stores the DTC. When shift solenoid valve S2 is ON, if its resistance is 8 Ω or less, the ECM determines there is a short in the shift solenoid valve S2 circuit. When shift solenoid valve S2 is OFF, if its resistance is 100 kΩ or higher, the ECM determines there is an open in the shift solenoid valve S2 circuit ([Click here](#)).

**WIRING DIAGRAM**

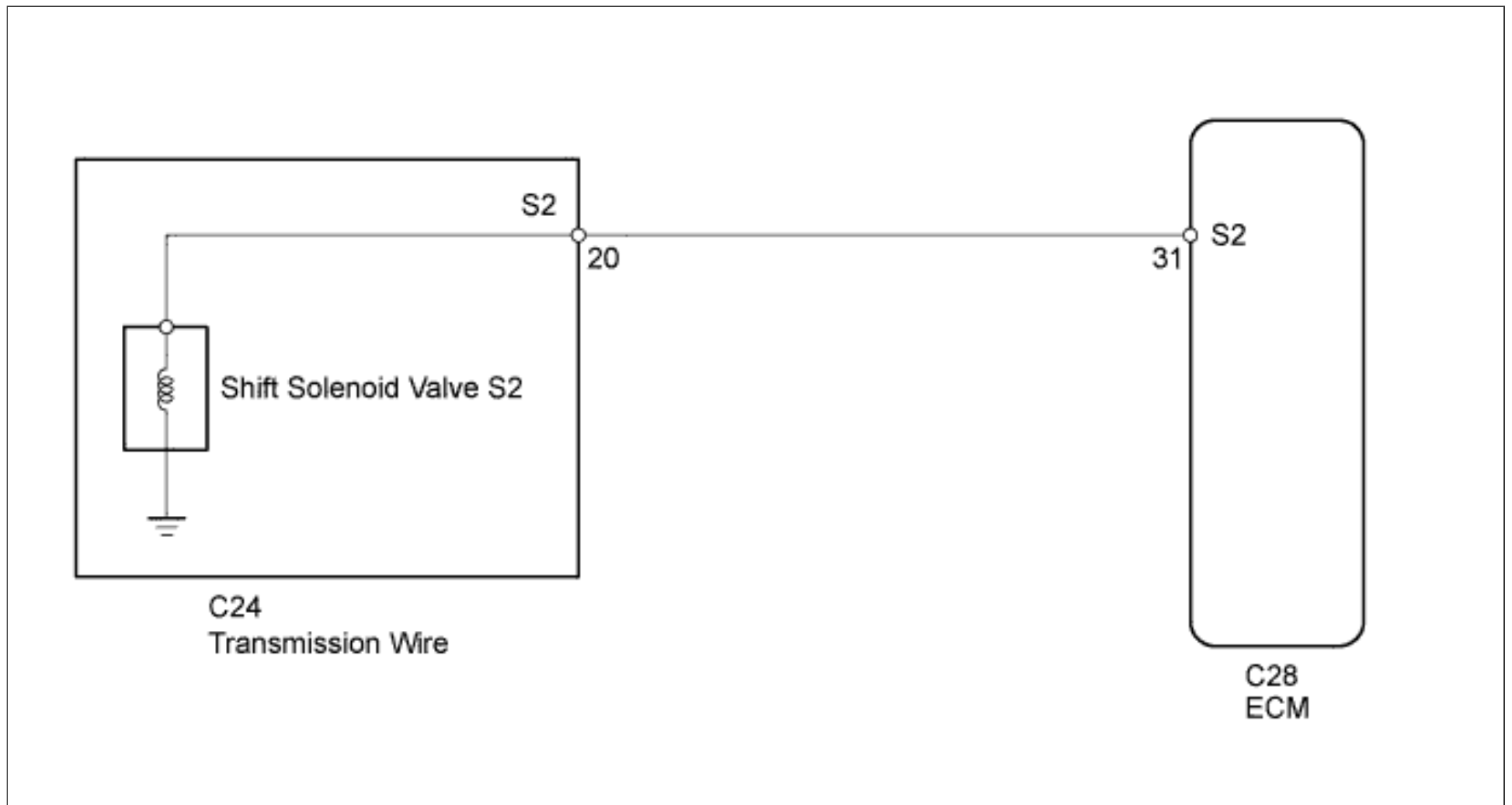

**INSPECTION PROCEDURE**

**HINT:**

Shift solenoid valve S2 is turned ON/OFF normally when the shift lever is in D:

ECM gear shift command	1st	2nd	3rd	4th	5th	6th
Shift solenoid valve S2	ON	ON	OFF	OFF	OFF	ON

**1.INSPECT TRANSMISSION WIRE (SHIFT SOLENOID VALVE S2)**

- a. Disconnect the C24 transmission wire connector.
- b. Measure the resistance according to the value(s) in the table below.

**Standard Resistance:**

--	--	--

Tester Connection	Condition	Specified Condition
20 (S2) - Body ground	20°C (68°F)	11 to 15 Ω

**Text in Illustration**

*a	Component without harness connected (Transmission Wire)
----	---

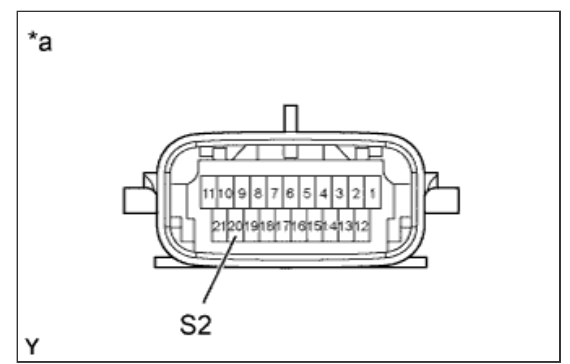

**NG**

[Go to step 3](#)

**OK**

**2.CHECK HARNESS AND CONNECTOR (TRANSMISSION WIRE - ECM)**

- a. Disconnect the C28 ECM connector.
- b. Measure the resistance according to the value(s) in the table below.

**Standard Resistance:**

Tester Connection	Condition	Specified Condition
C28-31 (S2) - Body ground	20°C (68°F)	11 to 15 Ω

**Text in Illustration**

*a	Front view of wire harness connector (to ECM)
----	---

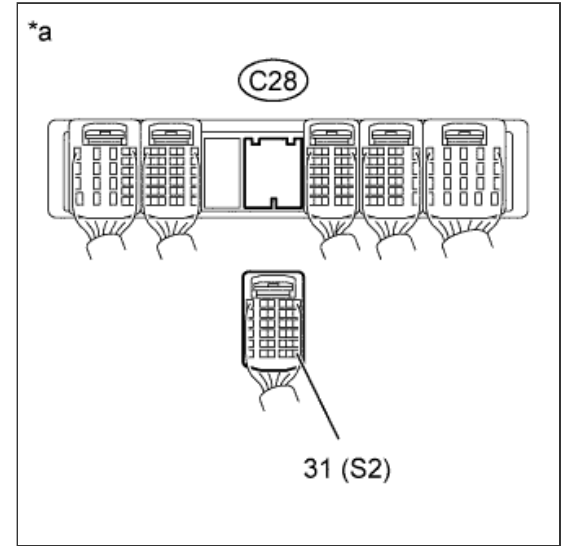

**NG**

**REPAIR OR REPLACE HARNESS OR CONNECTOR**

**OK**

**REPLACE ECM ([Click here](#))**

**3.INSPECT SHIFT SOLENOID VALVE S2**

- a. Remove shift solenoid valve S2.
- b. Measure the resistance according to the value(s) in the table below.

**Standard Resistance:**

Tester Connection	Condition	Specified Condition
Shift solenoid valve S2 connector terminal - Shift solenoid valve S2 body	20°C (68°F)	11 to 15 Ω

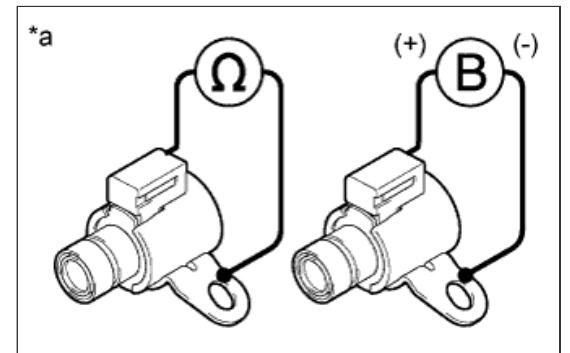

- c. Apply 12 V battery voltage to the shift solenoid valve and check that the valve moves and makes an operating noise.

**OK:**

Measurement Condition	Specified Condition
<ul style="list-style-type: none"> <li>• Battery positive (+) → Shift solenoid valve S2 connector</li> <li>• Battery negative (-) → Shift solenoid valve S2 body</li> </ul>	Valve moves and makes an operating noise

**Text in Illustration**

*a	Component without harness connected (Shift Solenoid Valve S2)
----	---

**NG**

**REPLACE SHIFT SOLENOID VALVE S2 ([Click here](#))**

**OK**

**REPAIR OR REPLACE TRANSMISSION WIRE ([Click here](#))**

