

Wire Harness Repair or Replacement Guide

Service Category Power Source/Network

Section Power Distribution

Market USA

Toyota Supports
ASE Certification 

Applicability

YEAR(S)	MODEL(S)	ADDITIONAL INFORMATION
2014 - 2017	CT200H	
2021 - 2022	ES250, LC500C	
2013 - 2022	ES300H, ES350, LX570, RX350, RX450H	
2016 - 2020	GS F	
2016 - 2017	GS200T, IS200T, RC200T	
2018 - 2019	GS300	
2015 - 2020	GS350	
2013 - 2018	GS450H	
2014 - 2022	GX460, IS350	
2014 - 2015	IS250	
2016 - 2022	IS300, RC300	
2022	IS500, NX250, NX350, NX350H, NX450H+	
2018 - 2022	LC500, LC500H, LS500, LS500H	
2013 - 2017	LS460	
2013 - 2016	LS600H	
2015 - 2017	NX200T	
2018 - 2021	NX300	
2015 - 2021	NX300H	
2015 - 2022	RC F, RC350	
2019 - 2022	UX200, UX250H	

Introduction

Wire Harness Repair or Replacement Guide

This Service Bulletin includes guidelines meant to help determine whether to repair or replace a wire harness assembly based on damage type. This Service Bulletin should be used in conjunction with the applicable model and model year Electronic Wiring Diagram (EWD) and/or Repair Manual.

NOTE

The guidelines in this Service Bulletin should ONLY be performed by technicians that have taken the Lexus Technical Training E-Learning Module LEC306A – *Wire Harness Repair*. For a summary of that module, reference "[QL621A Wire Harness Repair Quick Training Guide](#)" found on the Technical Information System (TIS), by accessing the following menus: *Technical Training – QTG – Skill Area: Electrical & A/C*.

Warranty Information

OP CODE	DESCRIPTION	TIME	OFF	T1	T2
N/A	Not Applicable to Warranty	–	–	–	–

Wire Harness Repair or Replacement Guide

Parts Information

For wire harness assembly replacement, look up the part(s) in the Electronic Parts Catalog (EPC) per the VIN. For wire harness repair parts information, use the wire harness repair information from the EWD component detail/wire harness repair screen. See the figure below for an example of this process.

Figure 1. EWD Parts Information Example

[+]Connector List Instrument Panel Instrument Panel Wire / No. 3 Instrument Panel Wire						
Name	Instrument Panel Wire and No. 2 Floor Wire					
Code	DG4	Part Number	90980-12862/90980-12861			
Spec		Color	White			
[-]Wire Harness Repair						
· WIRE HARNESS REPAIR GUIDELINES						
· TERMINAL AND CONNECTOR REPAIR PROCEDURES						
Caution Items	-					
Wire Type	Copper					
Terminal Type	1.5 (Non-waterproof Type)					
Male / Female	Female					
Sleeve	size:M (Silver) P/N: 82999-52020					
SST	P/N: 09991-00570					
		Repair Wire				
		<p style="text-align: right;">E = 2.0</p> <table border="1"> <tr> <td rowspan="2">P/N:</td> <td>160mm</td> <td>82998-24350</td> </tr> <tr> <td>500mm</td> <td></td> </tr> </table>		P/N:	160mm	82998-24350
P/N:	160mm	82998-24350				
	500mm					

Wire Harness Repair or Replacement Guide

Required Tools & Equipment

SPECIAL SERVICE TOOLS (SST)	PART NUMBER	QTY
Terminal Removal Tool Kit*	11819-00026	1

*Essential SST.

NOTE

Additional SSTs may be ordered by calling 1-800-933-8335.

Guides

- [Repair or Replacement Determination Guide](#) 5
- [Precautions for Repair Using Repair Wires and/or Connectors](#) 10
- [New Terminal Removal Tool Kit Information](#) 12

Wire Harness Repair or Replacement Guide

Repair or Replacement Determination Guide

BEFORE the wire harness assembly is repaired or replaced, locate the damaged portion and identify the causes of the damage.

NOTICE
 Serious malfunctions may result if the wire harness assembly is repaired or replaced without locating the damage or identifying the causes.

Table 1. Wire Harness Parts Information

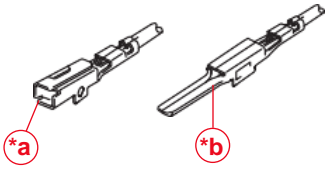
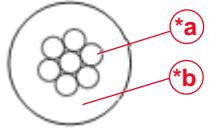
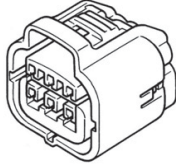
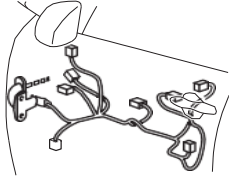
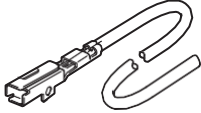
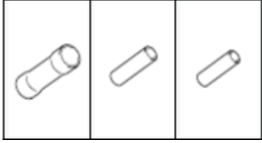
TERMS	REFERENCE IMAGE	TERMS	REFERENCE IMAGE
Terminals *a: Female *b: Male		Wires *a: Insulator *b: Core	
Connector		Wire Harness Assembly	
Repair Wire		Sleeves	

If the wire harness assembly damage is related to ANY of the circumstances below, repair is **NOT RECOMMENDED** as a quality repair and can NOT be guaranteed:

- Orange wire harness assemblies for high-voltage systems (e.g., hybrid systems)
- Large (greater than or equal to 8 sq. mm, approximately 8 AWG) wire harness assembly for high-current systems (e.g., alternator system)
- Flood-damaged vehicles
- Thermal event damaged vehicles
- Shielded wires, such as antenna cable and video data cable
- Supplemental Restraint System circuits

Wire harness repair instructions for the circumstances above may be found in other publications such as, Recalls, Campaigns, Service Bulletins, Tech Tips, etc. that have been approved to address specific conditions on specific vehicles. The instructions found in these publications should be followed for those specific instances.

Wire Harness Repair or Replacement Guide

Repair or Replacement Determination Guide (continued)

If the wire harness assembly damage is NOT related to ANY of the circumstances above, determine the best repair method by using the following information:

- Broken or separated wire
Recommended repair methods:
 - Wire repair
 - Wire harness assembly replacement

Figure 2.



- Bent or damaged male wire terminals
Recommended repair methods:
 - Wire terminal repair
 - Wire harness assembly replacement

Figure 3.



1	Not Good
2	Good

- Loose or damaged female wire terminals with poor tension/fit
Recommended repair methods:
 - Wire terminal repair
 - Wire harness assembly replacement

NOTE
Until the wire terminal gauge tool is available, for a suspected poor terminal tension condition, replace the entire wire harness if unable to effectively diagnose by other reasonable methods such as a wiggle test or visual inspection for looseness.

Figure 4.

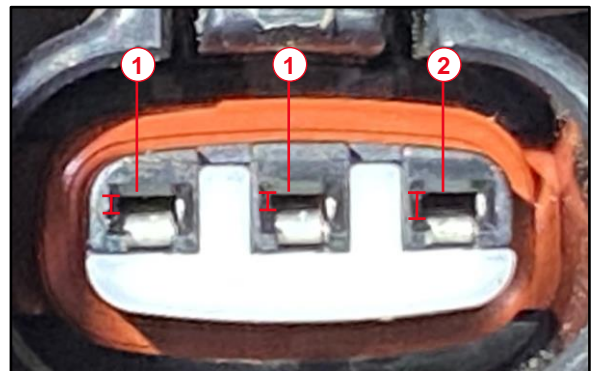

1	Good
2	Not Good (Female Wire Terminal With Poor Tension/Fit)

Wire Harness Repair or Replacement Guide

Repair or Replacement Determination Guide (continued)

- Broken connector-lock tab
Recommended repair methods:
 - Connector replacement
 - Wire harness assembly replacement

Figure 5.

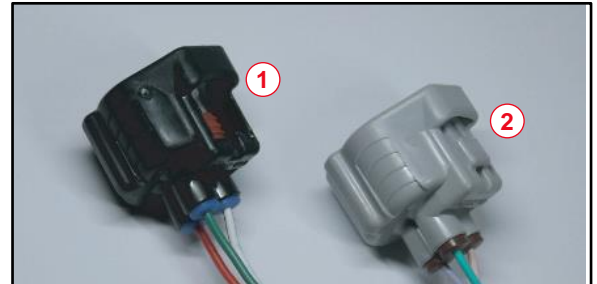

1	Not Good
2	Good

- Connector deformation caused by incorrect terminal probing
Recommended repair methods:
 - Connector replacement
 - Wire harness assembly replacement

Figure 6.

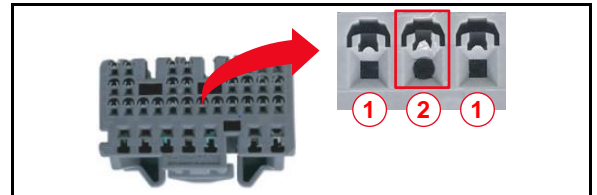

1	Good
2	Not Good

- Damaged weather seal
Recommended repair methods:
 - Repair wire replacement
 - Wire harness assembly replacement

Figure 7.

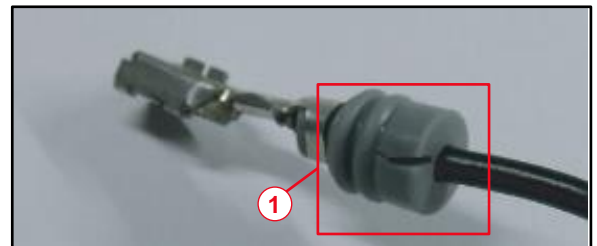

1	Damaged Weather Seal
----------	-----------------------------

Wire Harness Repair or Replacement Guide

Repair or Replacement Determination Guide (continued)

- Melted wires

NOTE

- It is difficult to precisely locate ALL areas that were damaged.
- Excessive heat impairs the flexibility and electrical conductivity of the wire harness assembly.

Recommended repair method:

- Wire harness assembly replacement

Figure 8. Melted Wires Examples

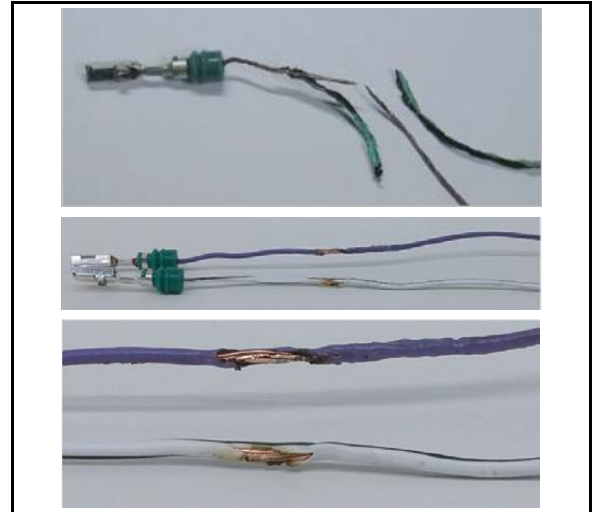

- Wire terminal discoloration

NOTE

- It is difficult to precisely locate ALL areas that were damaged.
- If a wire harness assembly repair is performed, corrosion or rust may still occur.

Recommended repair method:

- Wire harness assembly replacement

Figure 9.

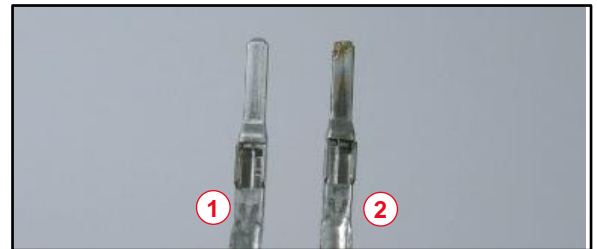

1	Good
2	Not Good

Wire Harness Repair or Replacement Guide

Repair or Replacement Determination Guide (continued)

- Wire terminal corrosion

NOTE

- It is difficult to precisely locate ALL areas that were damaged.
- If a wire harness assembly repair is performed, corrosion or rust may still occur.

Recommended repair method:

- Wire harness assembly replacement

Figure 10.

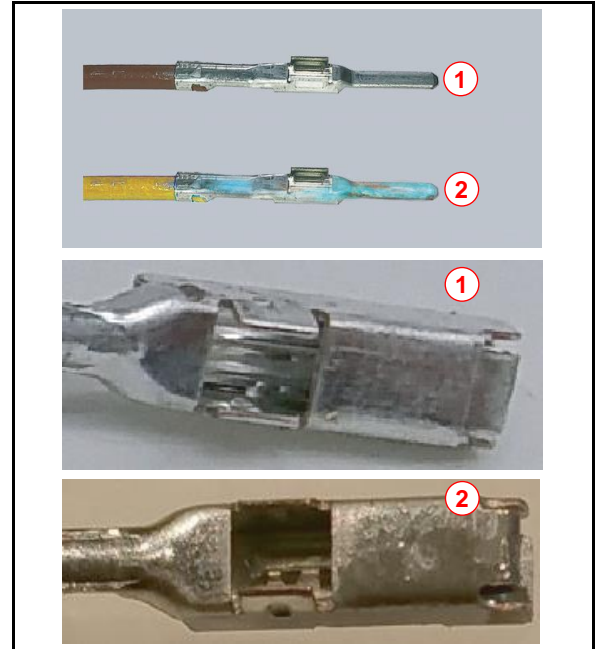

1	Good
2	Not Good

Wire Harness Repair or Replacement Guide

Precautions for Repair Using Repair Wires and/or Connectors

1. Confirm the necessary wire harness assembly repair tools are available.

NOTICE

- Wire harness assembly parts may be damaged or broken if the repair is conducted without using the appropriate tools.
- The vehicle repair quality may NOT be achieved if the repair is completed without using the appropriate parts.

2. Do NOT repair wires that are meant to bend (such as wires in the door-jamb area).

NOTICE

Original wire harness assembly routing or layout can NOT be restored, as sleeves can NOT bend. Doing so could cause the sleeve to break and this may lead to other malfunctions or problems.

3. Check if the removed protective wire harness assembly covers and clamps can be restored after the completion of the repair. If the protective covers or clamps can NOT be restored, the wire harness assembly may be damaged or produce unusual noise due to vibration or interference with the vehicle body or components. Replace covers and/or clamps as needed.
4. Repairing communication wire harness assemblies is NOT recommended, for example, CAN (Controller Area Network) communication. Repair causes the electrical resistance to vary, potentially blocking communication signals.
5. Ensure the remaining wire length is AT LEAST 30 mm to achieve the waterproof capability and insulation performance of a heat shrink sleeve.

Figure 11.

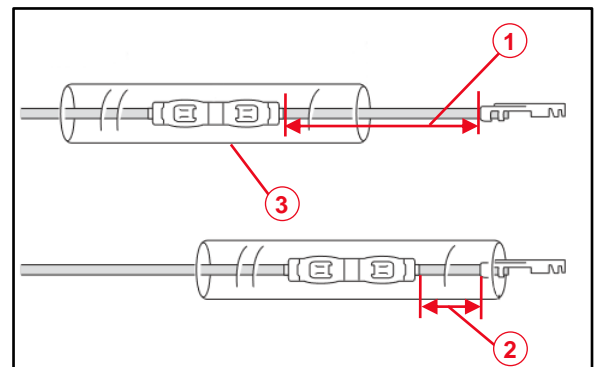

1	Good (30-mm Wire Length)
2	Not Good (Less Than 30-mm Wire Length)
3	Heat Shrink Sleeve

Wire Harness Repair or Replacement Guide

Precautions for Repair Using Repair Wires and/or Connectors (continued)

6. Avoid the heat shrink sleeves being adjacent to each other when several wires connected to the same connector need to be repaired simultaneously.

NOTE

The protective wire harness assembly cover or clamps may NOT be restored if the heat shrink sleeves are adjacent to each other.

Figure 12. Heat Shrink Sleeves in Good Locations

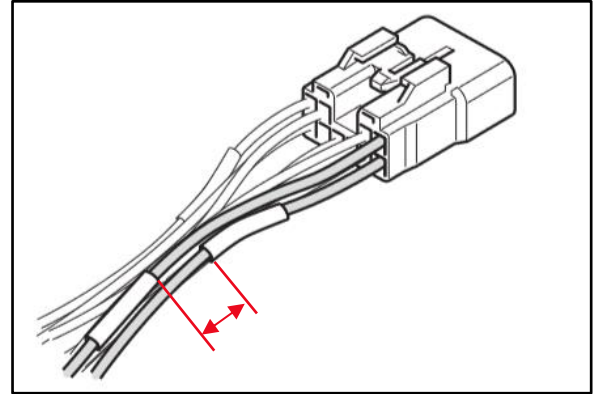

7. Cut the repaired wire or the existing wire, whichever one will help you to obtain the same wire length as the original one AFTER the repair.
 - The repaired wire may have an open or short circuit due to vibration if it is too long.
 - The repaired wire may have an open or short circuit due to vibration if it is too short.
 - Terminal deformation or poor contact may also result from a repaired wire being too long or too short.

Figure 13.

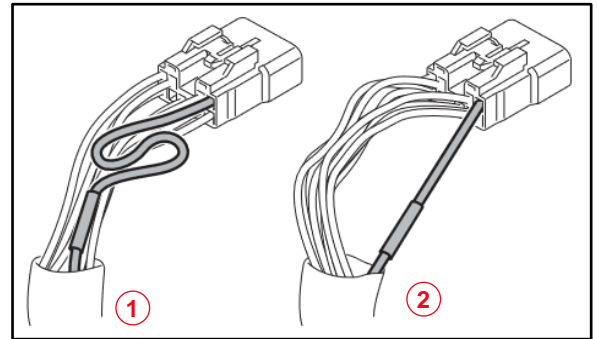

1	Repaired Wire is Too Long
2	Repaired Wire is Too Short

Wire Harness Repair or Replacement Guide

New Terminal Removal Tool Kit Information

A NEW terminal removal tool kit was developed for wire harness repair. This kit includes 10 tools that can be used for multiple terminal and connector types. This section includes instructions for using the NEW wire terminal removal tool kit.

Figure 14. Terminal Removal Tool Kit



Wire Harness Repair or Replacement Guide

New Terminal Removal Tool Kit Information (continued)

1. Confirm terminal type.
 - A. Select the connector that is to be serviced within the EWD and open the component detail view for that connector.

Figure 15.

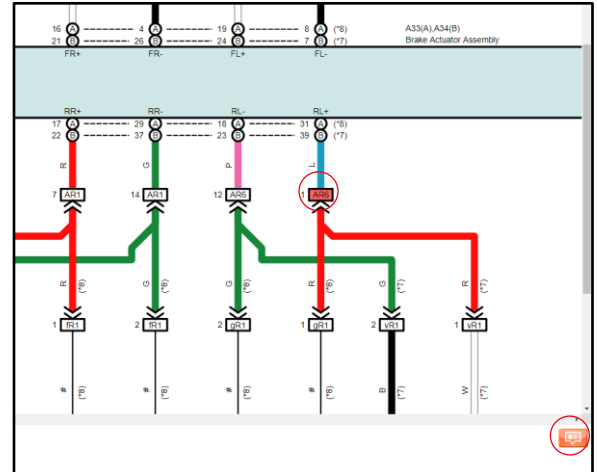

- B. Within the component detail view, expand the Wire Harness Repair section and confirm the terminal type.

Figure 16. Component Detail View

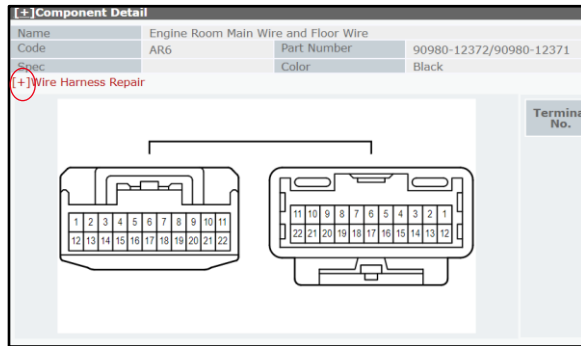
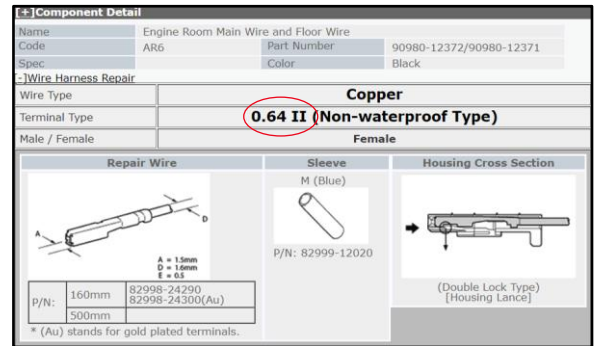

Figure 17. Terminal Type Example













Wire Harness Repair or Replacement Guide

New Terminal Removal Tool Kit Information (continued)

2. Confirm the necessary tool by looking up the corresponding blade part number per terminal type by using the table below.

Table 2.

ILLUSTRATION	PART NUMBER	PART NAME	NOTES AND PURPOSE
	09991-00500	Lance Canceling Tool	For Terminal Removal/ 0.64 Non-waterproof Type, Female
	09991-00510		For Terminal Removal/ 0.64 Non-waterproof Type, Male
	09992-01030		For Terminal Removal/ 0.64 II Non-waterproof Type, Male 0.64 II Non-waterproof Type, Female
	09991-00520	Lance Canceling Tool No. 1	For Terminal Removal/ 0.5 Non-waterproof Type, Female 0.5 W Non-waterproof Type, Female
	09991-00530	Lance Canceling Tool No. 2	For Terminal Removal/ 0.5 II Waterproof Type, Female 0.64 Non-waterproof Type, Female
	09991-00560	Lance Canceling Tool No. 3	For Terminal Removal/ 0.64 Waterproof Type, Male
	09991-00570	Lance Canceling Tool No. 4	For Terminal Removal/ 1.5 Non-waterproof Type, Male 1.5 Non-waterproof Type, Female
	09041-1C570	Minus screwdriver 1.8 mm	For Terminal Removal (to Release Retainer)/ 0.64 II Male, Mainly 2.3 - 8.0, etc.
	09041-1C580	Minus Screwdriver 0.9 mm	For Terminal Removal (to Release Retainer)/ Mainly 1.0 – 2.3 II, etc.
	09991-00550	Retainer Remover A	For Retainer Release/ 0.64 Waterproof Type, Male

3. Use the corresponding tool(s) to disassemble the connector and remove the terminal. Use the procedures taught in the Lexus Technical Training E-Learning Module LEC306A and the [“QL621A Wire Harness Repair Quick Training Guide.”](#)

NOTICE

Wire harness assembly parts may be damaged or broken if this tool kit is NOT used correctly and carefully.