

Part Number: PT228-60141

Kit Contents

Item #	Quantity Req'd.	Description
1	1	Hitch Assembly
2	1	Wiring Harness Bracket
3	1	Hardware Bag
4	1	Hitch Cover
5	2	Center Spacer

Hardware Bag Contents

Item #	Quantity Req'd.	Description
1	6	M12 x 1.25 x 50mm bolt
3	2	M12 x 1.25 x 55mm bolt <i>(see template below for sizes)</i>
4	4	M8 x 1.25 x 35mm bolt w/washer
5	2	M8 x 1.25 x 20mm bolt
6	1	Cable Tie w/push mount head
7	2	Cable Tie with standard head
8	1	Corrugated Slit Tubing

Additional Items Required For Installation

Item #	Quantity Req'd.	Description
1		

Conflicts

None

Recommended Tools

Personal & Vehicle Protection	Notes
Safety Glasses	
Vehicle Protection	Cloth (shop towel)
Special Tools	Notes
L.E.D. Tester – 4-pin	SST 00002-62195
L.E.D. Tester – 7-pin	IADS# TUN07-024-02 (PPO only)
Installation Tools	Notes
Exhaust Hanger Removal Tool	e.g. Snap-on p/n Ya3202
Socket Wrench	
Socket Extension	6"
Sockets	10mm, 12mm, 17mm 12mm flex-head
Torque Wrench (x2)	0-100 lbf-ft, 0-100 lbf-in
Electrical Tape	
Small Flathead Screwdriver	
Phillips head screwdriver	
Diagonal side cutter	
Special Chemicals	Notes
None	

General Applicability

MY14 and newer GX models with Tow Package

Recommended Sequence of Application

Item #	Accessory
1	

*Mandatory

Vehicle Service Parts (may be required for reassembly)

Item #	Quantity Req'd.	Description

Legend

STOP: Damage to the vehicle may occur. Do not proceed until process has been complied with.

OPERATOR SAFETY: Use caution to avoid risk of injury.

CAUTION: A process that must be carefully observed in order to reduce the risk of damage to the accessory/vehicle and to ensure a quality installation.

TOOLS & EQUIPMENT: Used in Figures calls out the specific tools and equipment recommended for this process.

REVISION MARK: This mark highlights a change in installation with respect to previous issue.

SAFETY TORQUE: This mark indicates that torque is related to safety.

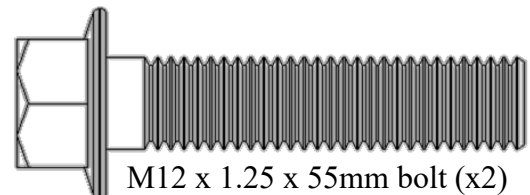
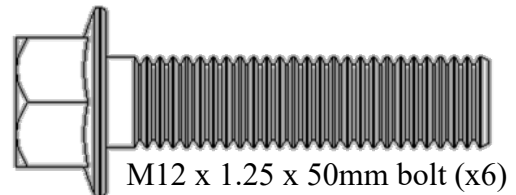

Care must be taken when installing this accessory to ensure damage does not occur to the vehicle. The installation of this accessory should follow approved guidelines to ensure a quality installation.

These guidelines can be found in the "Accessory Installation Practices" document.

This document covers such items as:-

- Vehicle Protection (use of covers and blankets, cleaning chemicals, etc.).
- Safety (eye protection, rechecking torque procedure, etc.).
- Vehicle Disassembly/Reassembly (panel removal, part storage, etc.).
- Electrical Component Disassembly/Reassembly (battery disconnection, connector removal, etc.).

Please see your Lexus dealer for a copy of this document.

1. Prepare the Vehicle for Hitch Installation.

- (a) Verify the kit contents.
- (b) Lower the spare tire, shift the tire forward away from the frame cross member and raise it back up to create additional space for the hitch installation.

-  (c) Cover the exhaust pipe with a clean shop towel.

 **CAUTION:** The muffler may be sharp and/or hot.

- (d) **For vehicles with Sport Appearance Package, remove and discard trim piece, Finisher-A. Discard the (6) clips removed from the vehicle (Fig. 1-1).**

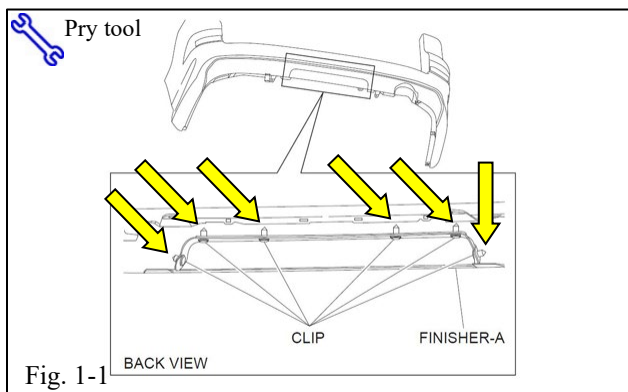

- (e) Remove and save the vehicle tie down on the driver's side frame rail. Discard the (2) bolts removed from the vehicle (Fig. 1-2).

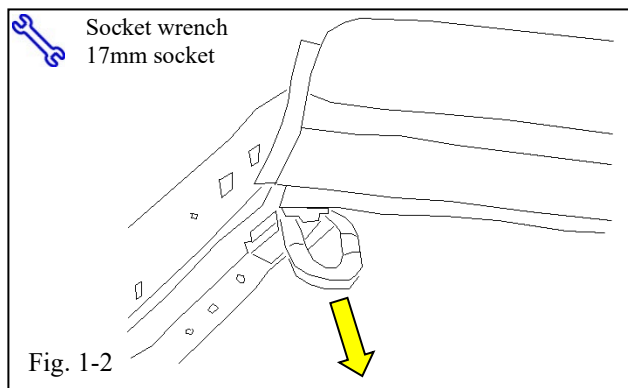

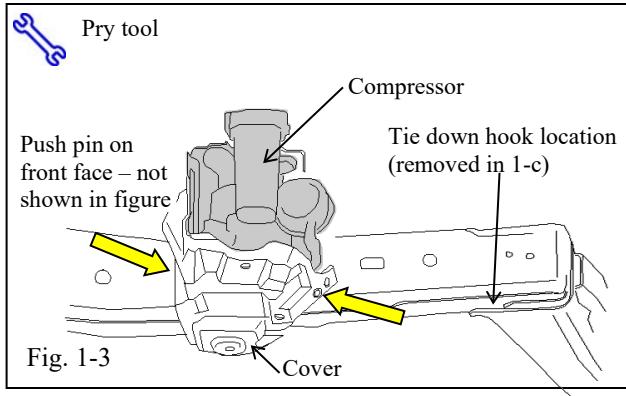

- (f) If Compressor is present, remove (2) plastic push pin connectors to remove the plastic cover from the air suspension compressor unit. Set the cover and fasteners aside for later use (Fig.1-3).

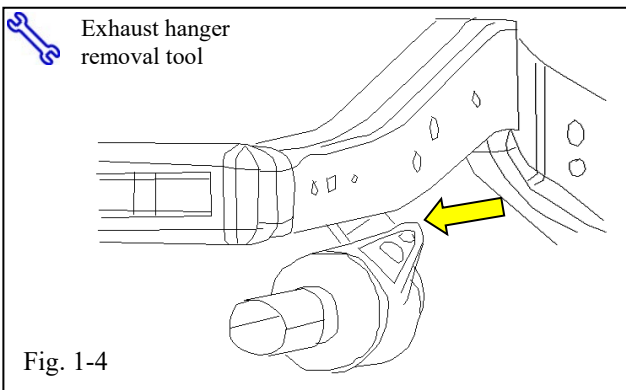

- (g) Disconnect the rubber exhaust hanger from one of the connection points and lower the exhaust (Fig. 1-4).

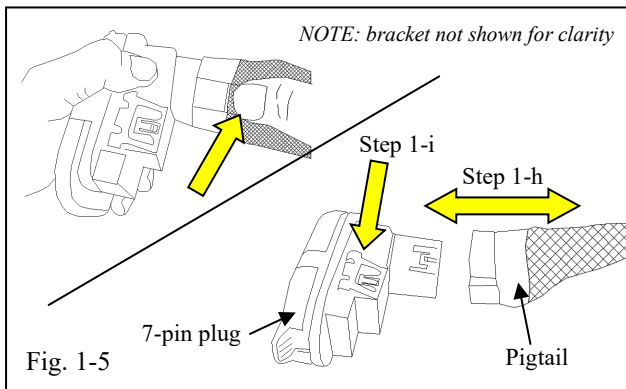

- (h) Disconnect the wire harness 7-pin plug from the pigtail. Press on the tab as shown in Fig. 1-5 to unlatch the connector plug housing.
- (i) Push in on the metal spring clips on the top and bottom of the 7-pin wire harness plug to release it from the bracket. Remove the plug from the bracket and set it aside for later use. Discard the bracket.

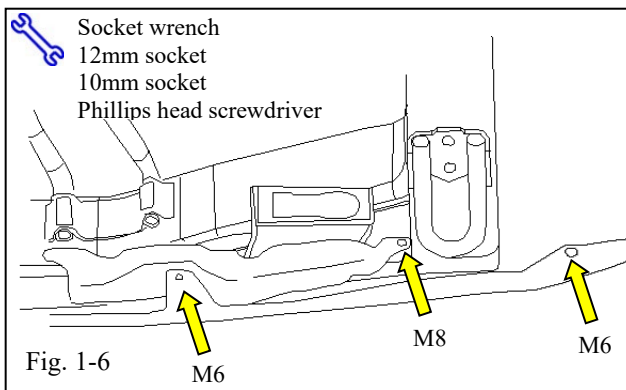

- (j) Remove the vertical M8 bolt attaching the fascia bracket (if present) to the frame. Remove the M6 bolt that attaches the fascia tab to the bracket. Remove the outboard M6 fascia bolt. Set the bolts aside for later use. Carefully pull the bracket down to gain clearance for removal of wire the harness bracket bolts (Fig. 1-6).

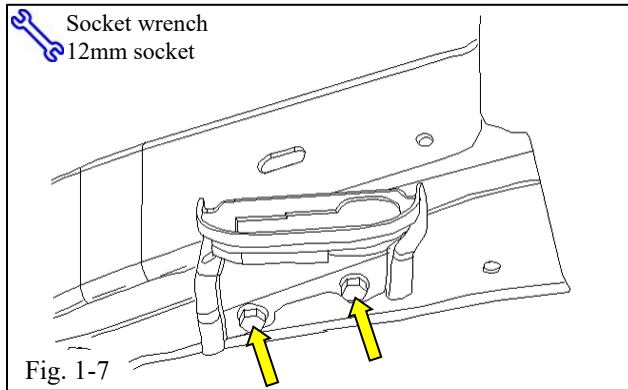

- (k) Remove and discard the two (2) M8 bolts securing the factory wiring bracket to the frame (Fig. 1-7).
- (l) If previously removed, carefully push the fascia bracket back into its original position (Fig. 1-5).

- i. Reinstall the (1) M8 bolt. Tighten to 25 N•m (19 lbf•ft).

Torque: 24.5 N•m (18 lbf•ft)

- ii. Reinstall the (1) M6 bracket bolt. Tighten to 8 N•m (72 in•lbf).

Torque: 8 N•m (72 in•lbf)

- iii. Reinstall the (1) M6 outboard fascia bolt and tighten.

2. Prepare the Wire Harness.

⚠ NOTE: All work in the following steps on the wire harness is done in place on the vehicle. The harness remains connected to the frame.

- (a) Carefully remove the tape covering the strain relief mesh and the (2) corrugated tubes (Fig. 2-1).

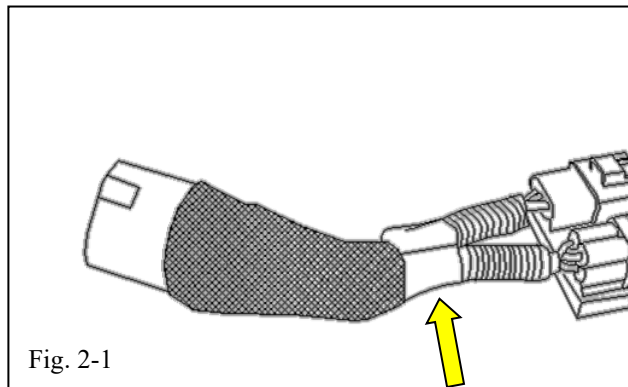

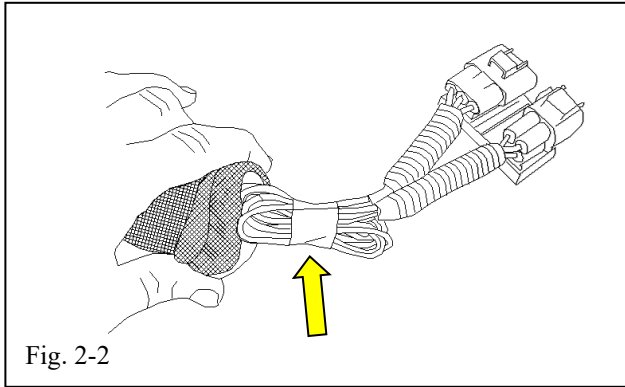

- (b) Pull back the mesh to expose the extra length of wiring wrapped underneath. Remove the tape holding the wiring together (Fig. 2-2).

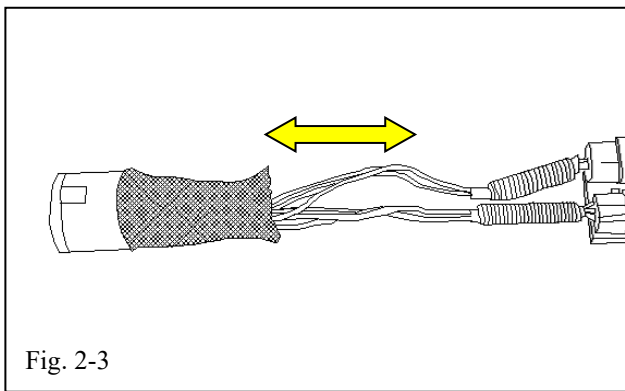

- (c) After removing the tape, unfold and straighten out the extra wiring (Fig. 2-3).

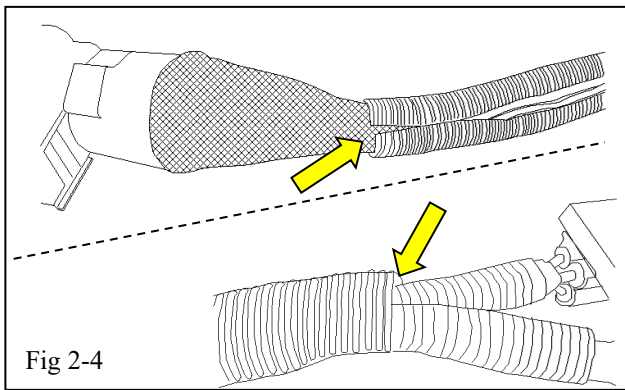

- (d) Use the corrugated, slit tubing provided in the component kit to cover the exposed length of wiring. Begin at one end and continue along the length to the opposite end. Be sure that the mesh netting and the (2) smaller tubes are captured underneath the slit tubing (Fig. 2-4).

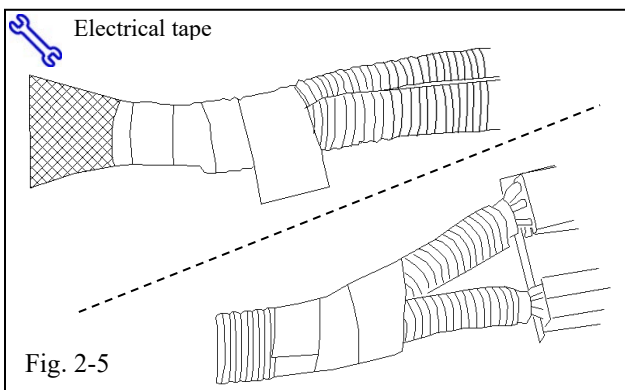

- (e) Use electrical tape to secure each end of the slit corrugated tubing to the wire harness. Add a few loops around the center of the tube (Fig. 2-5).

- (f) Use a standard head (not push mount) cable tie to secure each of the ends of the wrapped tape.

⚠ NOTE: Do not install the cable tie so tight that the corrugated tubing starts to squeeze and collapse (Fig. 2-6).

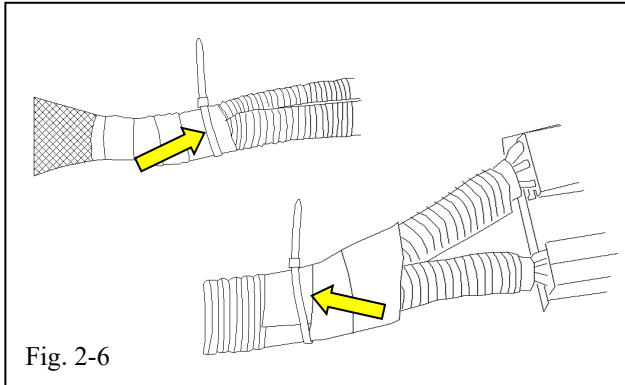

- (g) Trim off the ends of the cable ties (Fig. 2-7).

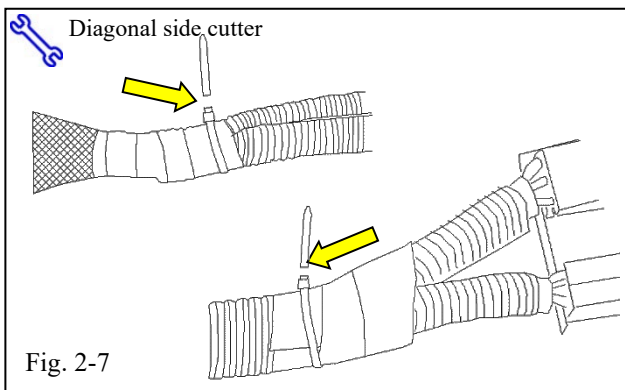

3. Install the Wire Harness to the Hitch.

- (a) Install wire harness plug removed in Step 1(i) into the bracket provided in hitch kit. Snap the connector into place (Fig. 3-1).

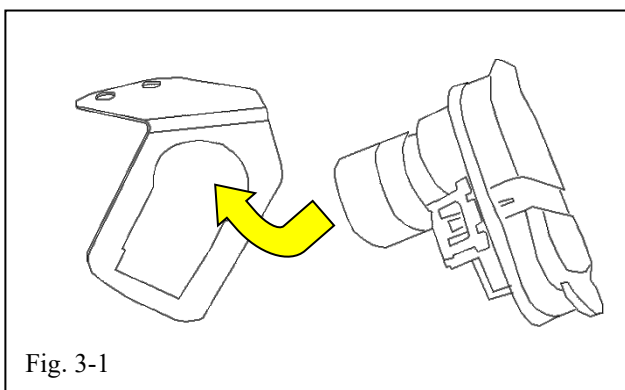

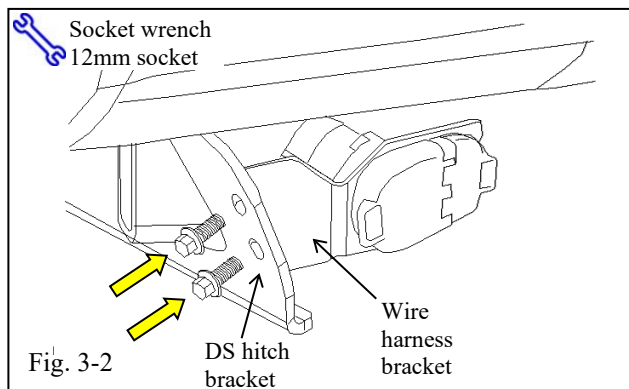

- (b) Install the wire harness bracket to the inside surface of the driver's side hitch bracket. Secure it loosely using (2) M8 x 20 mm bolts (Fig. 3-2).

4. Install the Hitch to the Vehicle Frame

- !** Separate the (8) M12 bolts by length prior to hitch installation to ensure the bolts are installed in the correct locations. The kit contains (6) 50mm bolts and (2) 55mm bolts.

+ **NOTE:** This step (Step 4) requires two people.

- (a) Reinstall the tie-down to the driver's side hitch bracket and attach the tie down and hitch to the frame using (2) M12 x 50mm bolts in the rearward most frame holes. These should be hand tighten enough to allow the hitch to hang (Fig. 4-1).

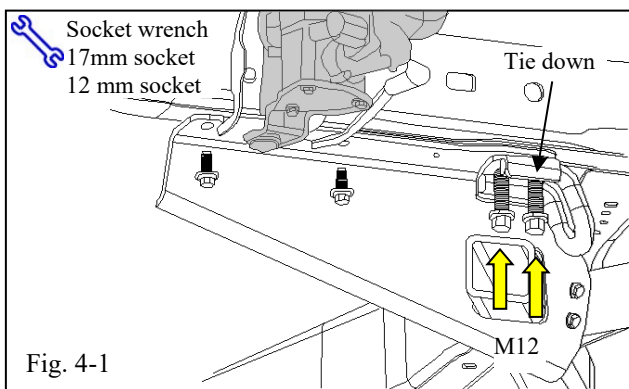

- (b) Attach the passenger's side hitch bracket to the frame using (2) M12 x 50mm bolts (Fig 4-2)

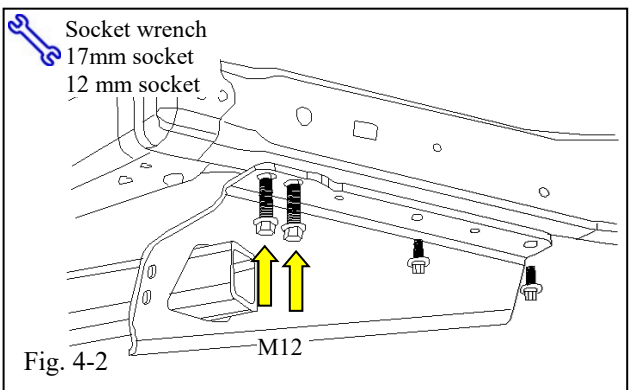

NOTE: The M12x50 bolts should be hand tighten enough to allow the hitch to hang and be able to be shifted fore-aft

- (c) Align the hitch with (2) spacer plates and the center frame bracket assembly and lift it into position. Install (2) M12 x 50mm bolts from underneath the hitch top plate, through the spacer plates, and into the frame bracket weld nuts (Fig. 4-3).

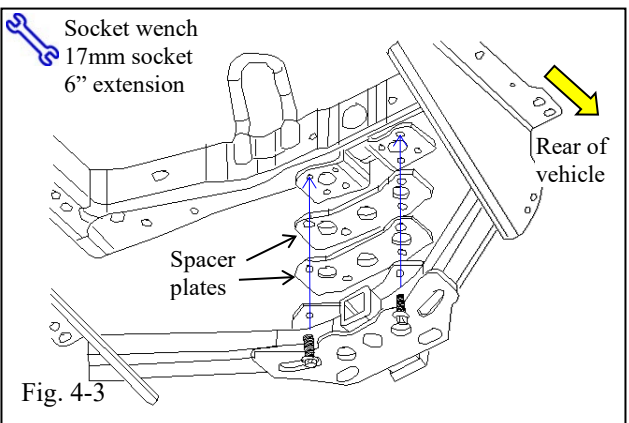

NOTE: It may be necessary to shift the hitch fore-aft in order to correctly align it to the center frame bracket holes.

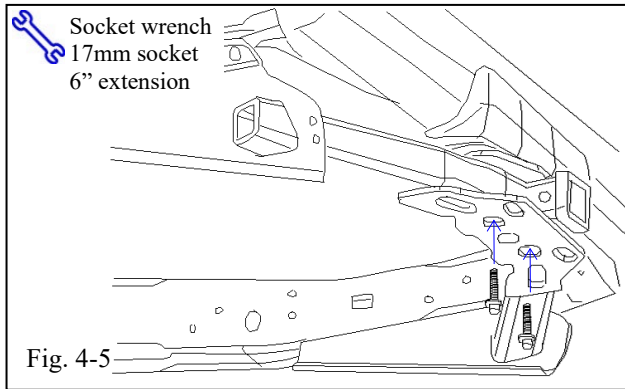

(d) Install (2) M12 x 55mm bolts by feeding the bolts through the holes in the bottom of the hitch cross tubes, through the (2) spacer plates, and into the rearmost weld nuts on the frame bracket (Fig. 4-5).

(e) Install (2) M8 bolts each on the driver's and passenger's sides (Fig. 4-6 & Fig. 4-7).

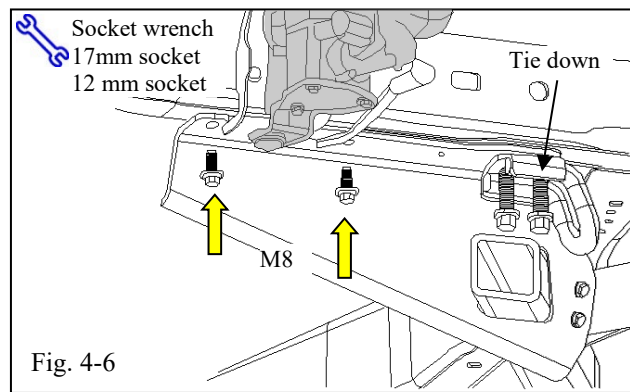

NOTE: While the hitch is hanging and loose fitting ensure the M8 hitch holes are aligned with the vehicle side rail holes and not sitting on any weld beads

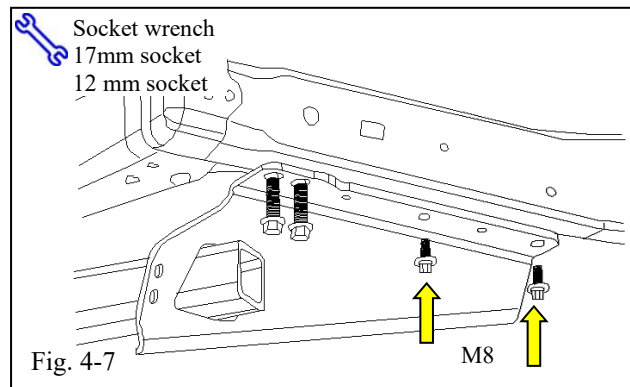

5. Reconnect and secure wire harness.

- (a) Plug the wire harness pigtail back into the connector plug housing (Fig. 5-1).

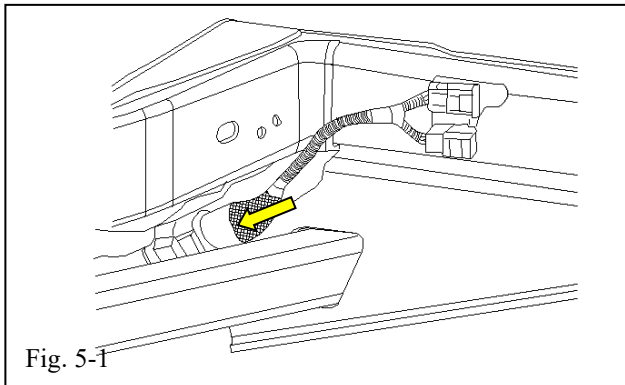

Fig. 5-1

- (b) Wrap a push-mount head cable tie around the wire harness tubing and install the push mount into the slot in the frame cross member to secure it (Fig. 5-2).

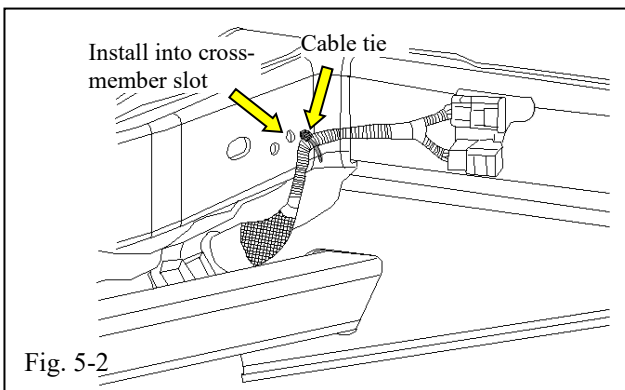
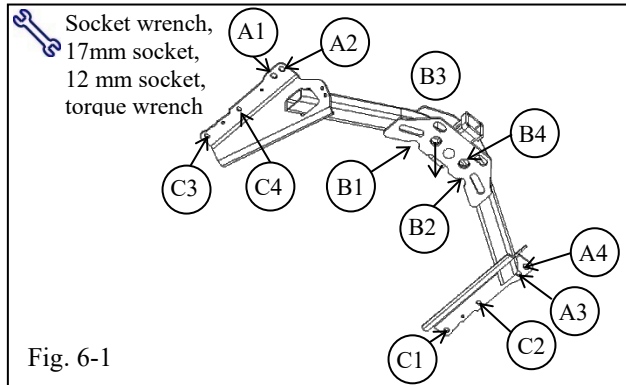

Fig. 5-2



6. Tighten the Hitch Hardware.

⚠ NOTE: Tighten the bolts in the order specified in Fig. 6-1.

(a) Tighten (4) M12 bolts on the frame rails (labeled A1-A4, Fig. 6-1).

⚠ Torque: 88 N•m (65 lbf•ft)

⚠ (b) Tighten (4) M12 bolts in the center (labeled B1-B4, Fig. 6-1).

⚠ Torque: 88 N•m (65 lbf•ft)

⚠ (c) Tighten (4) M8 bolts on the frame rail (labeled C1-C4, Fig. 6-1).

⚠ Torque: 31 N•m (23ft•lbf)

⚠ (d) Rotate bracket down (away from bumper) and tighten (2) M8 wire harness bracket bolts (Fig. 6-2). Note that the bracket and wire harness may contact the bumper after install.

Torque: 24.5 N•m (18 ft•lbf)

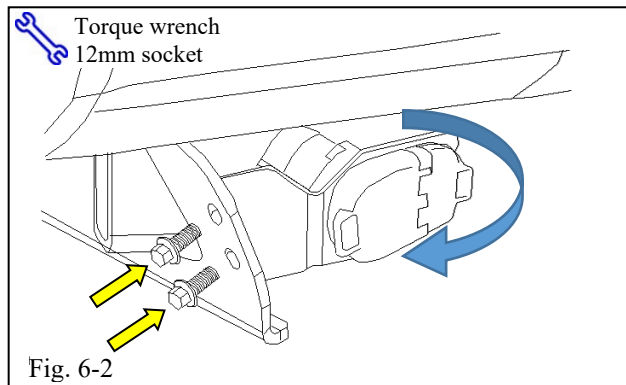

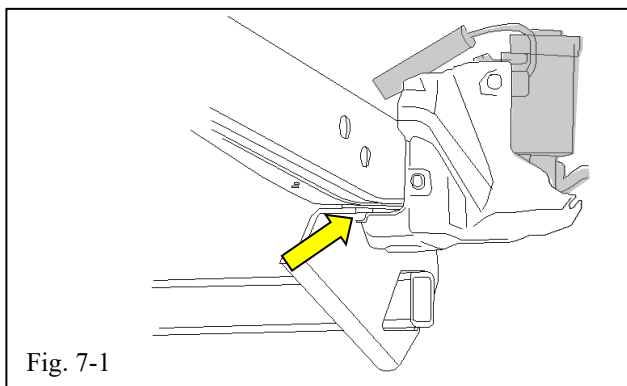

Fig. 7-1



7. Complete the Installation.

- (a) Reconnect the exhaust to the exhaust hanger. Ensure that hanger is fully engaged.
- (b) If previously removed, reinstall the air suspension compressor cover using the (2) plastic push-pins removed in Step 1(d) (Fig. 7-1).

NOTE: The cover will fit tightly against the hitch bracket.

- (c) Place the hitch plug in the glove compartment.
- (d) Perform a function check on the 4-pin trailer harness connector.
- (e) Perform a function check on the 7-pin trailer harness connector.

Checklist - these points **MUST** be checked to ensure a quality installation.

<u>Check:</u>	<u>Look For:</u>
<p><u>Accessory Function Checks</u></p> <ul style="list-style-type: none"> <input type="checkbox"/> All bolts are tightened to proper specifications <input type="checkbox"/> Center spacers  <input type="checkbox"/> 4-pin connector  <input type="checkbox"/> 7-pin connector <input type="checkbox"/> Wiring bracket <input type="checkbox"/> Hitch plug 	<ul style="list-style-type: none"> Installed between hitch and center frame bracket assembly 4-pin connector should function properly 4-pin connector should function properly Installed with wiring fed between hitch and vehicle cross member Placed in glove compartment
<p><u>Vehicle Function Checks</u></p> <ul style="list-style-type: none"> <input type="checkbox"/> <input type="checkbox"/> 	
<p><u>Vehicle Appearance Check</u></p> <ul style="list-style-type: none"> <input type="checkbox"/> After accessory installation and removal of protective cover(s), perform a visual inspection. 	<p>Ensure no damage (including scuffs and scratches) was caused during the installation process. (For PPO installations, refer to TMNA Accessory Quality Shipping Standard.)</p>