

<b>Last Modified:</b> 10-5-2010	6.4 K	<b>From:</b> 200907
<b>Model Year:</b> 2010	<b>Model:</b> HS250H	<b>Doc ID:</b> RM000001PZI00IX
<b>Title:</b> AUDIO / VIDEO: RADIO RECEIVER: COMPONENTS (2010 HS250H)		

## COMPONENTS

## ILLUSTRATION

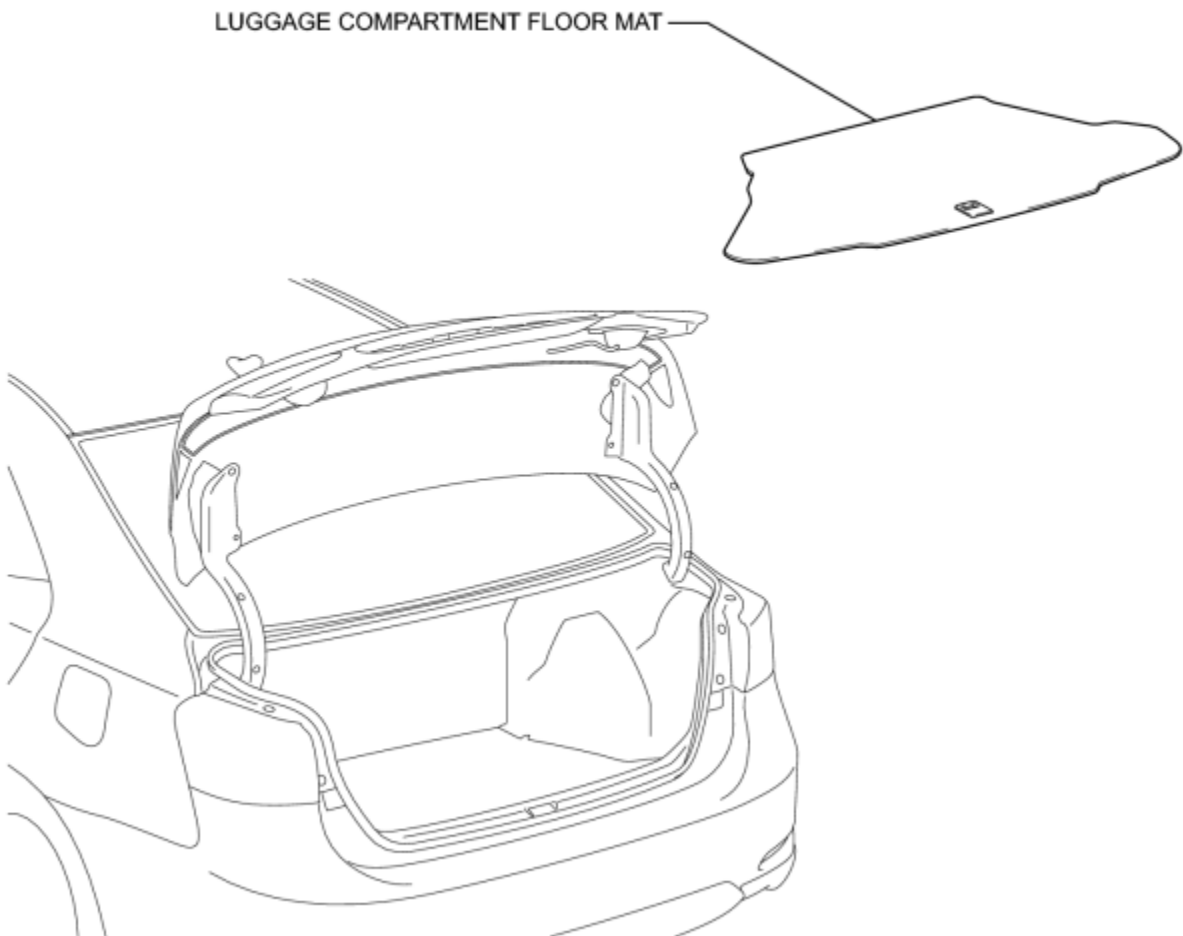

# ILLUSTRATION

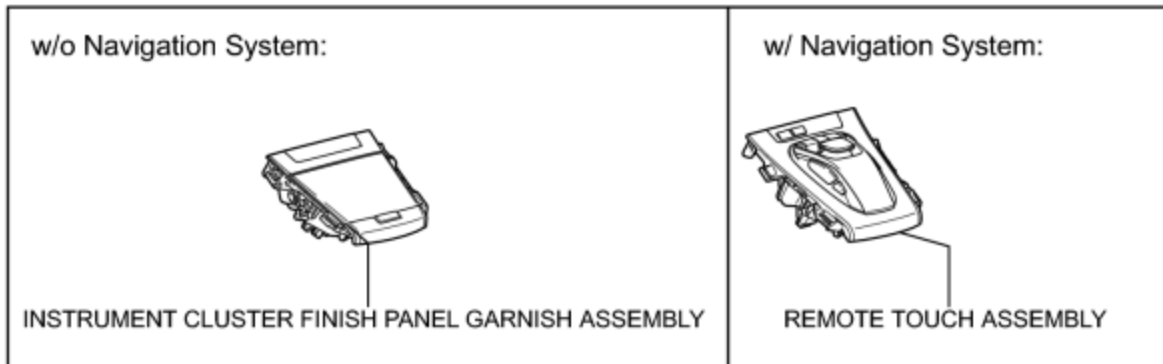
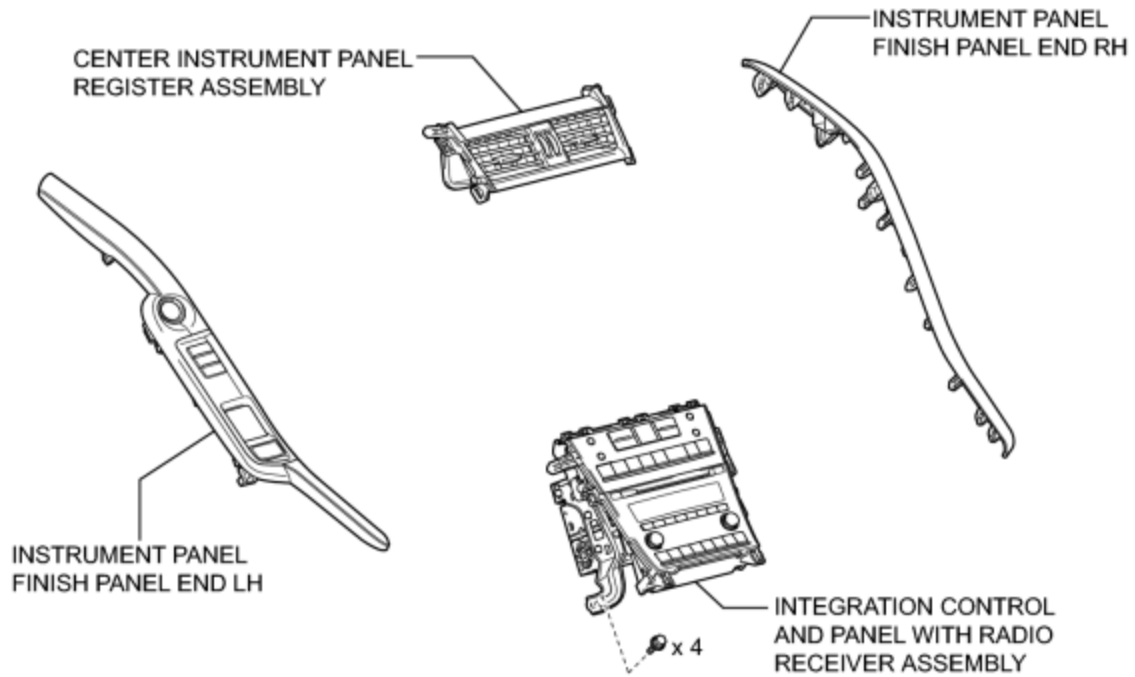

# ILLUSTRATION

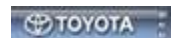
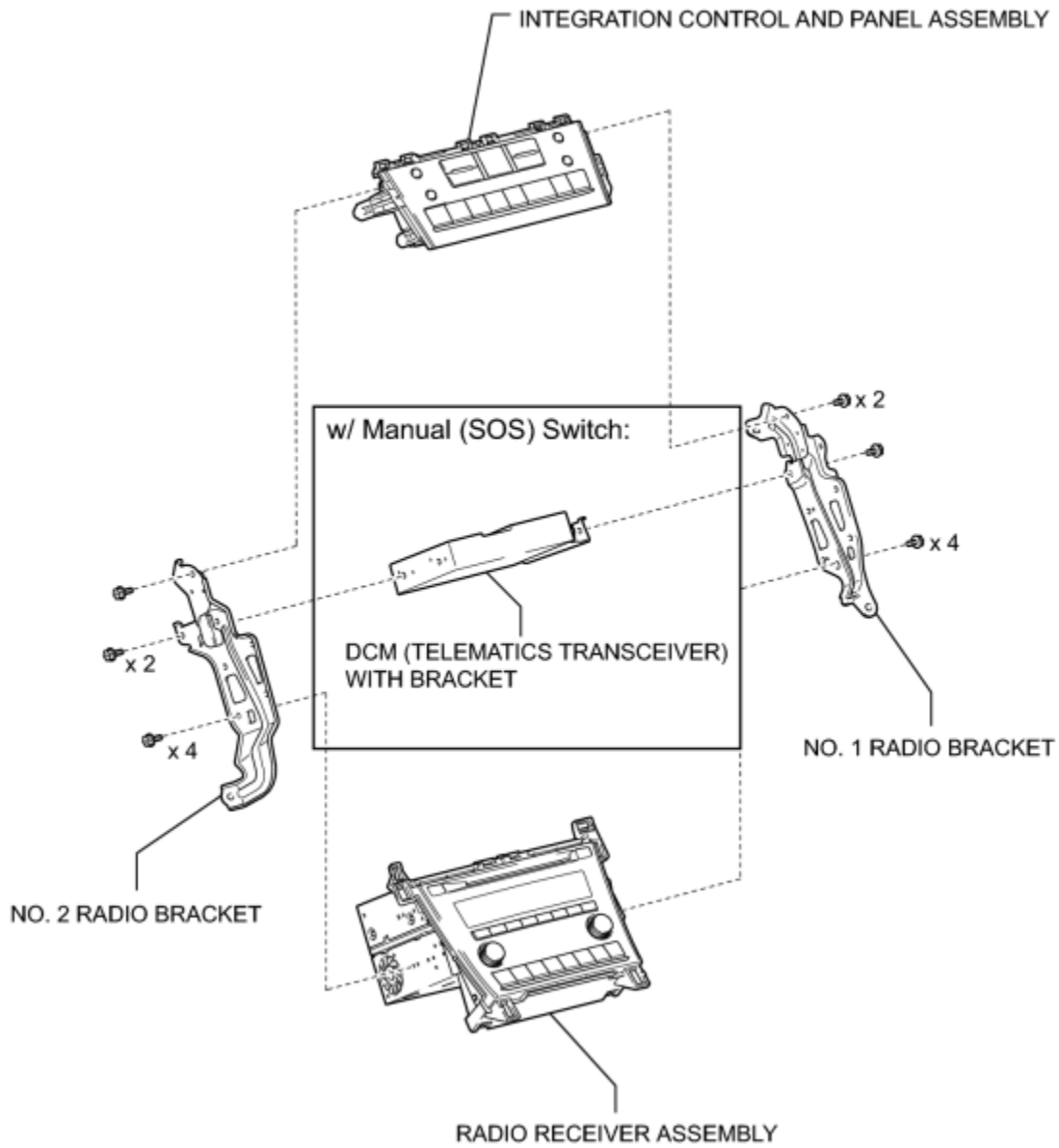

<b>Last Modified:</b> 10-5-2010	6.4 A	<b>From:</b> 200907
<b>Model Year:</b> 2010	<b>Model:</b> HS250H	<b>Doc ID:</b> RM000001PZJ00UX
<b>Title:</b> AUDIO / VIDEO: RADIO RECEIVER: REMOVAL (2010 HS250H)		

## REMOVAL

### 1. PRECAUTION (w/ Navigation System)

#### NOTICE:

After the power switch is turned off, the display and navigation module display (HDD navigation system) records various types of memory and settings. As a result, after turning the power switch off, make sure to wait at least 60 seconds before disconnecting the cable from the negative (-) battery terminal.

2. REMOVE LUGGAGE COMPARTMENT FLOOR MAT\_ [INFO](#)
3. DISCONNECT CABLE FROM NEGATIVE BATTERY TERMINAL\_ [INFO](#)
4. REMOVE INSTRUMENT PANEL FINISH PANEL END LH\_ [INFO](#)
5. REMOVE INSTRUMENT PANEL FINISH PANEL END RH\_ [INFO](#)
6. REMOVE INSTRUMENT CLUSTER FINISH PANEL GARNISH ASSEMBLY (w/o Navigation System)\_ [INFO](#)
7. REMOVE REMOTE TOUCH ASSEMBLY (w/ Navigation System)\_ [INFO](#)
8. REMOVE CENTER INSTRUMENT PANEL REGISTER ASSEMBLY\_ [INFO](#)
9. REMOVE INTEGRATION CONTROL AND PANEL WITH RADIO RECEIVER ASSEMBLY

(a) Remove the 4 bolts.

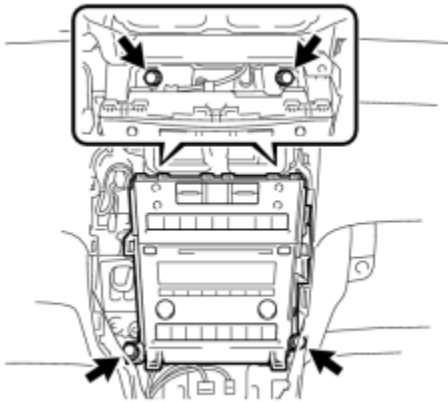

P

(b) Pull the integration control and panel with radio receiver assembly toward the rear of the vehicle.

(c) Disconnect each connector and remove the integration control and panel with radio receiver assembly.

10. REMOVE DCM (TELEMATICS TRANSCEIVER) WITH BRACKET (w/ Manual (SOS) Switch) INFO

11. REMOVE NO. 1 RADIO BRACKET

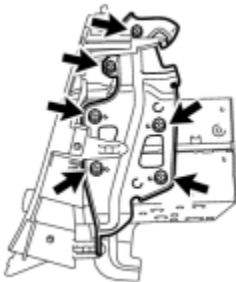

P

(a) Remove the 6 bolts and No. 1 radio bracket.

12. REMOVE NO. 2 RADIO BRACKET

(a) Remove the 5 bolts and No. 2 radio bracket.

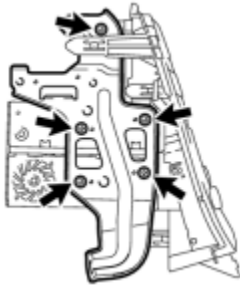

P

### 13. REMOVE RADIO RECEIVER ASSEMBLY

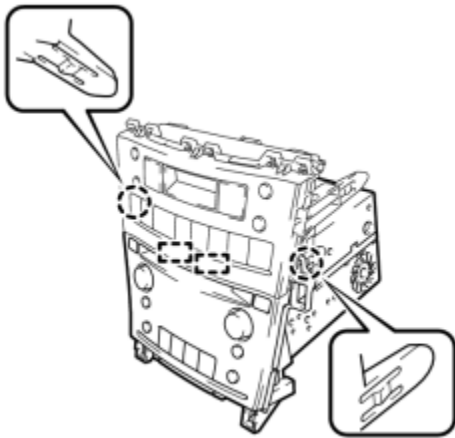

(a) Disengage the 2 claws and 2 guides to remove the radio receiver assembly from the integration control and panel assembly.

P

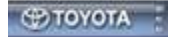

<b>Last Modified:</b> 10-5-2010	6.4 A	<b>From:</b> 200907
<b>Model Year:</b> 2010	<b>Model:</b> HS250H	<b>Doc ID:</b> RM000001PZH00UX
<b>Title:</b> AUDIO / VIDEO: RADIO RECEIVER: INSTALLATION (2010 HS250H)		

## INSTALLATION

### 1. INSTALL RADIO RECEIVER ASSEMBLY

(a) Engage the 2 claws and 2 guides to install the radio receiver assembly to the integration control and panel assembly.

### 2. INSTALL NO. 2 RADIO BRACKET

(a) Install the No. 2 radio bracket with the 5 bolts.

### 3. INSTALL NO. 1 RADIO BRACKET

(a) Install the No. 1 radio bracket with the 6 bolts.

### 4. INSTALL DCM (TELEMATICS TRANSCEIVER) WITH BRACKET (w/ Manual (SOS) Switch) [INFO](#)

### 5. INSTALL INTEGRATION CONTROL AND PANEL WITH RADIO RECEIVER ASSEMBLY

(a) Connect each connector.

(b) Install the integration control and panel with radio receiver assembly with the 4 bolts.

### 6. INSTALL CENTER INSTRUMENT PANEL REGISTER ASSEMBLY [INFO](#)

### 7. INSTALL REMOTE TOUCH ASSEMBLY (w/ Navigation System) [INFO](#)

### 8. INSTALL INSTRUMENT CLUSTER FINISH PANEL GARNISH ASSEMBLY (w/o Navigation System) [INFO](#)

### 9. INSTALL INSTRUMENT PANEL FINISH PANEL END RH [INFO](#)

### 10. INSTALL INSTRUMENT PANEL FINISH PANEL END LH [INFO](#)

### 11. CONNECT CABLE TO NEGATIVE BATTERY TERMINAL [INFO](#)

12. INSTALL LUGGAGE COMPARTMENT FLOOR MAT\_ 

13. ADJUST CLOCK

