

[Account](#)[Vehicle](#)[Help](#)[Search](#)[Contact](#)[AutoZone Community](#)[Exit](#)

Your Vehicle: **2008 Lexus LS 600h V8-5.0L (2UR-FSE) Hybrid**

[Vehicle](#) » [Transmission and Drivetrain](#) » [Continuously Variable Transmission/Transaxle](#) » [Fluid - CVT](#) » [Service and Repair](#)

Service and Repair

L110F HYBRID TRANSMISSION / TRANSAXLE: HYBRID TRANSMISSION FLUID: ADJUSTMENT

ADJUSTMENT

1. BEFORE REFILLING TRANSMISSION

- This transmission requires Toyota Genuine [ATF](#) WS.
- After servicing the transmission, you must refill the transmission with the correct amount of fluid.
- If fluid has seeped out or an oil cooler hose has been disconnected, proceed to "FILL TRANSMISSION PAN". If any of the entire transmission, transmission pan, drain plug, transmission wire or oil pressure switches is replaced, proceed to "FILL TRANSMISSION".
- Maintain the vehicle in a horizontal position while adjusting the fluid level.
- If the entire transmission is replaced, proceed to the "PERFORM FLUID CIRCULATION" procedure. **HINT:** New transmissions are already filled with transmission fluid.

2. FILL TRANSMISSION PAN **NOTICE:**

- Fill with [ATF](#) while the transmission is at normal operating temperature.
- After filling [ATF](#), adjust the fluid level.

(a) Lift the vehicle up while keeping the vehicle level.

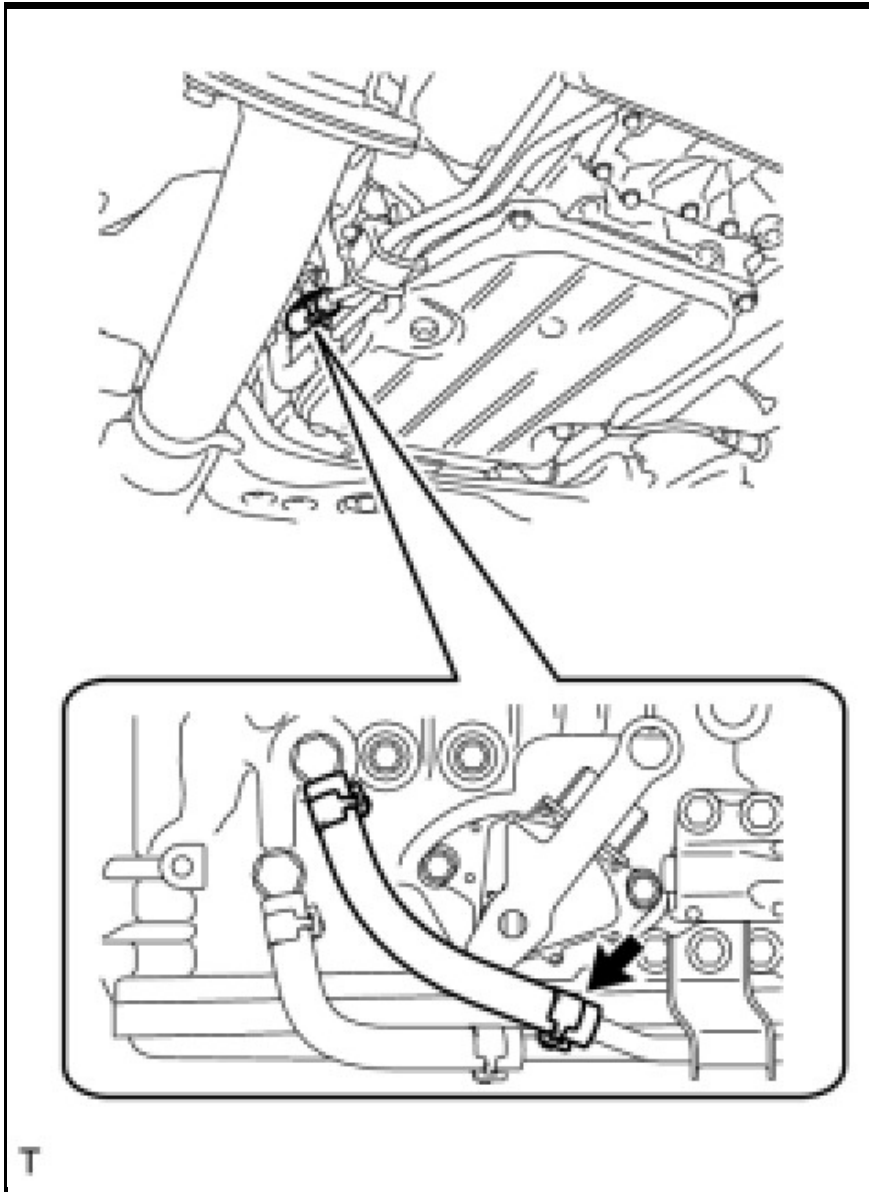

Zoom Sized for Print

(b) Disconnect the oil cooler hose.

NOTE: Do not touch any high temperature parts, such as the exhaust pipe.

HINT: Cover the disconnected oil cooler hose with a plastic bag or tape to prevent fluid from dripping.

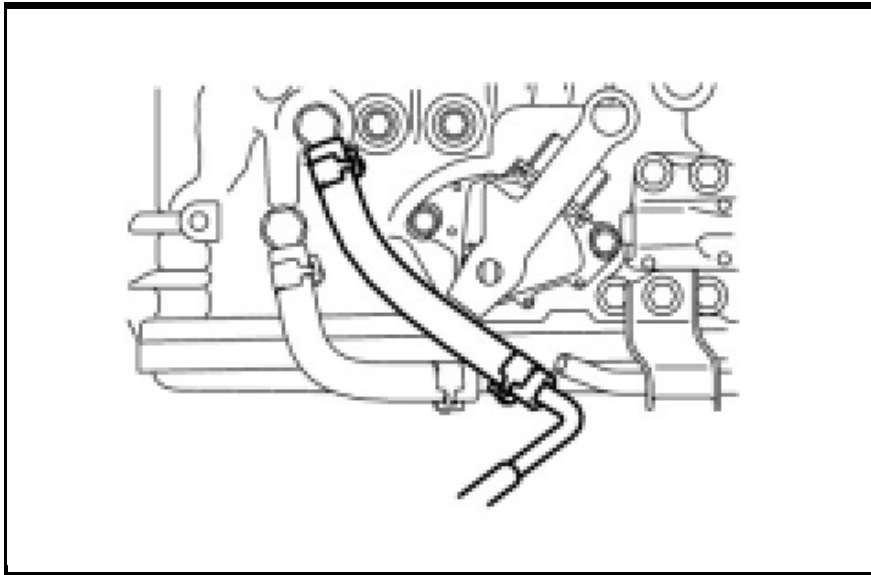

Zoom

Sized for Print

(c) Add fluid until it comes out of the disconnected oil cooler hose.

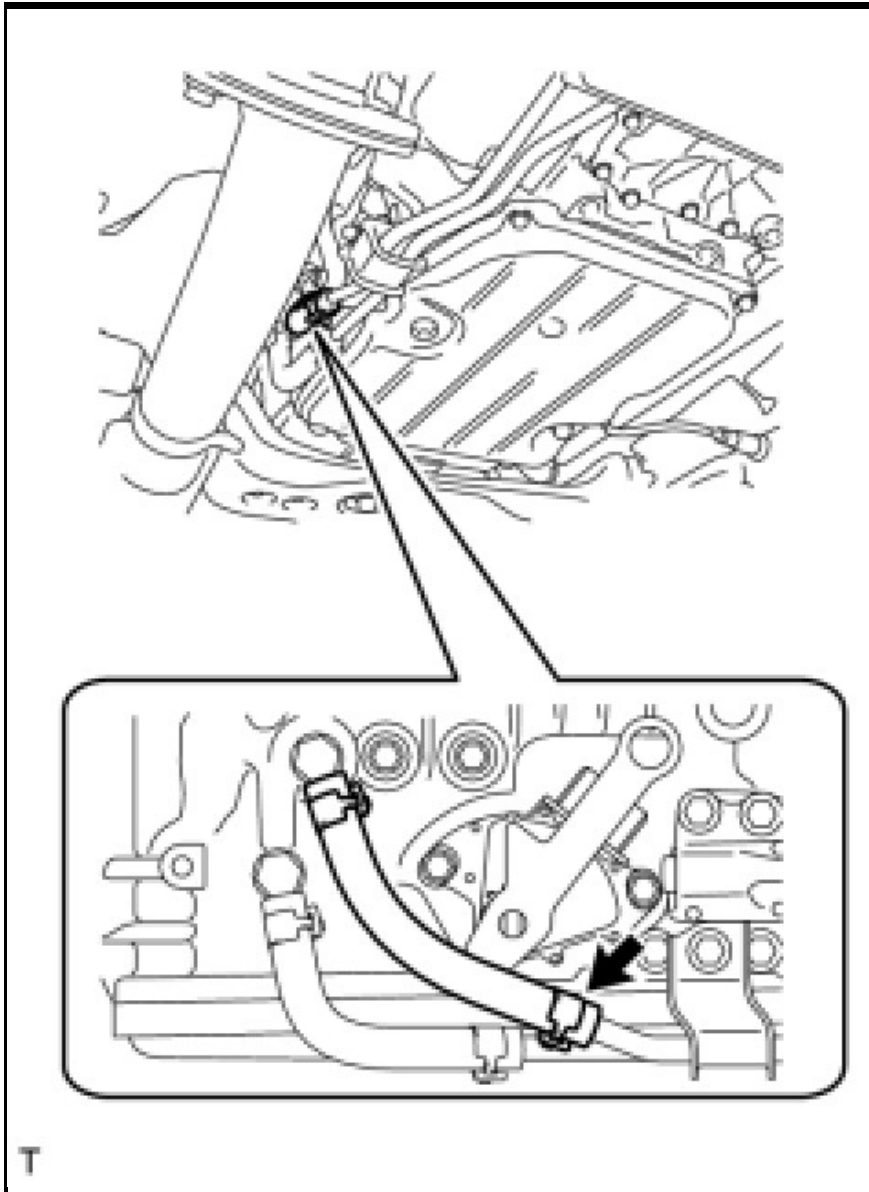

Zoom

Sized for Print

(d) Connect the oil cooler hose.

NOTE: Be sure to adjust the fluid level after adding fluid.

HINT: Proceed to "PERFORM FLUID CIRCULATION".

3. FILL TRANSMISSION **NOTICE:**

- Fill with **ATF** while the transmission is at normal operating temperature.
- After filling **ATF**, adjust the fluid level.

(a) Lift the vehicle up while keeping the vehicle level.

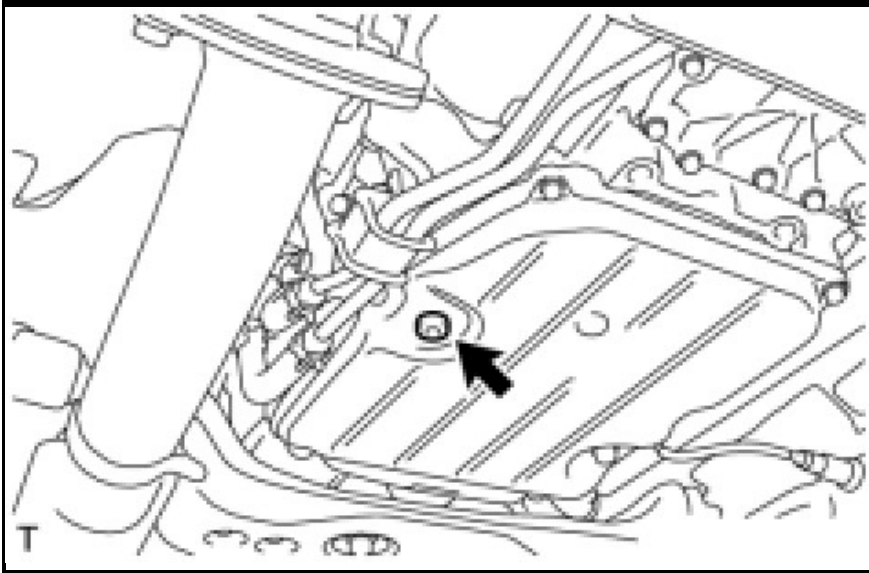

Zoom

Sized for Print

(b) Remove the overflow plug.

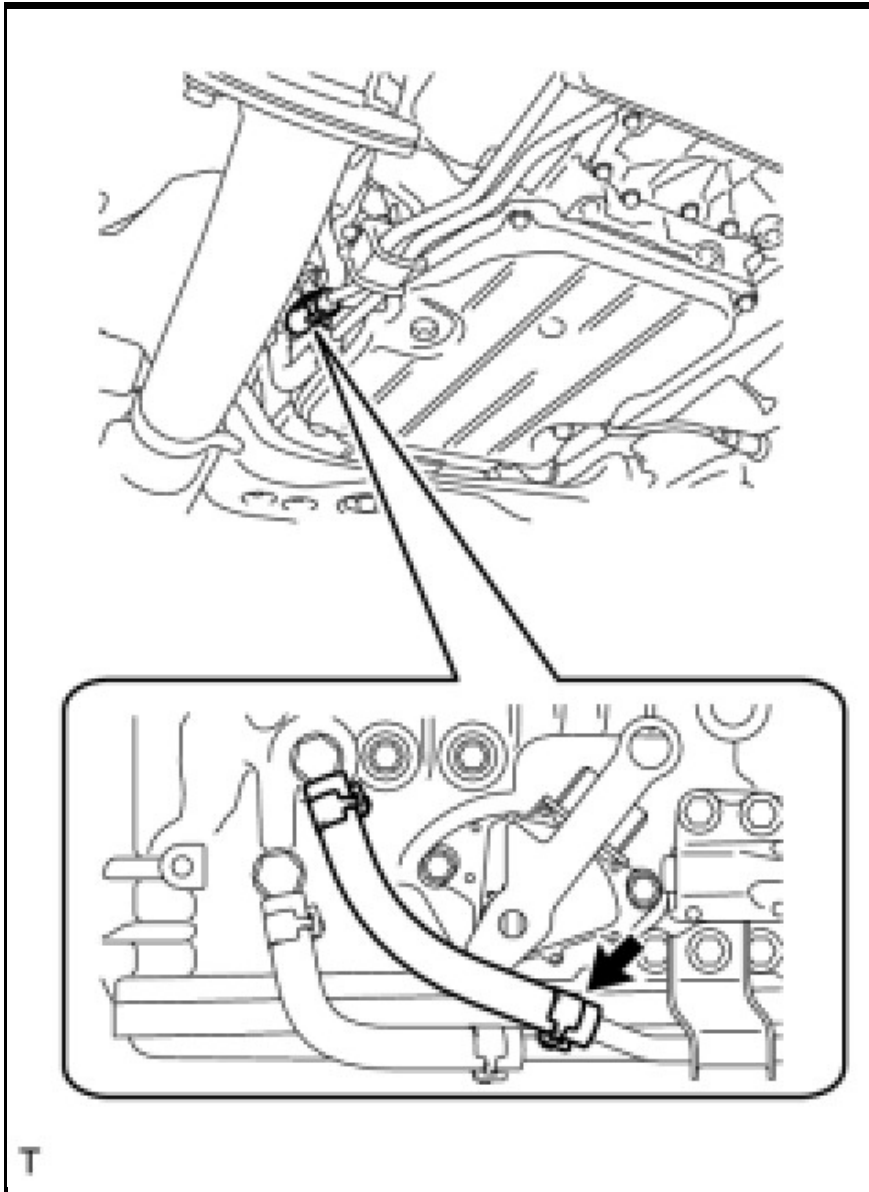

Zoom Sized for Print

(c) Disconnect the oil cooler hose.

NOTE: Do not touch any high temperature parts, such as the exhaust pipe.

HINT: Cover the disconnected oil cooler hose with a plastic bag or tape to prevent fluid from dripping.

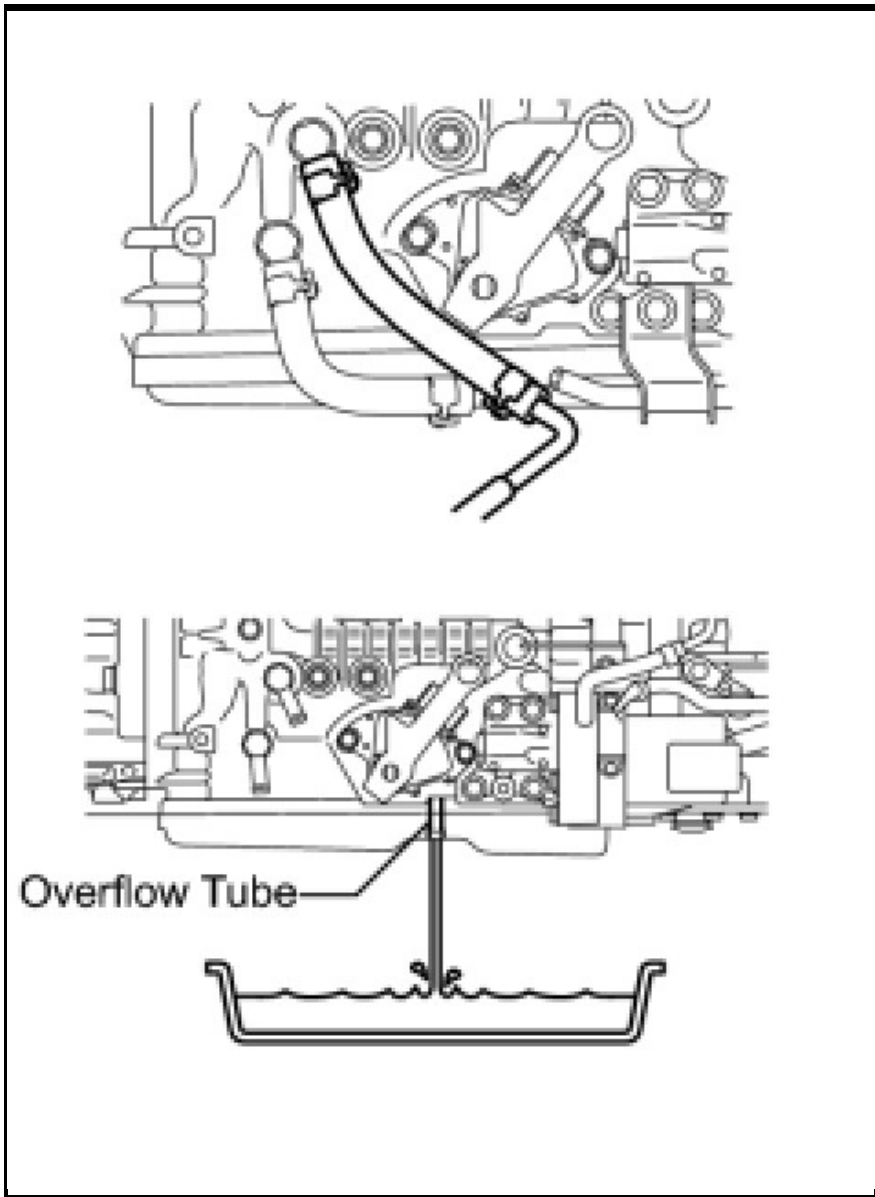

Zoom Sized for Print

(d) Add fluid to the disconnected oil cooler hose until fluid comes out of the overflow tube.

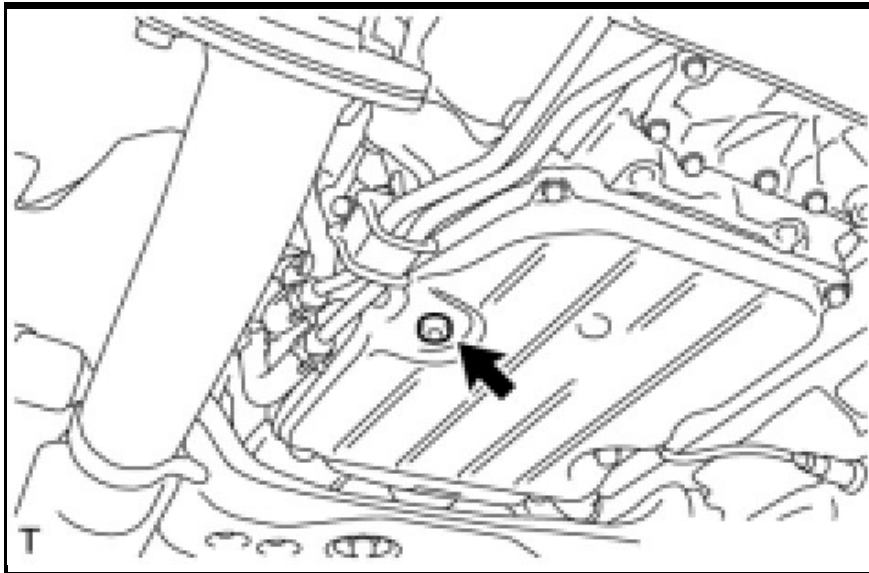

Zoom Sized for Print

(e) Reinstall the overflow plug.

HINT: The overflow plug will be removed again later. Therefore, reuse the gasket at this step.

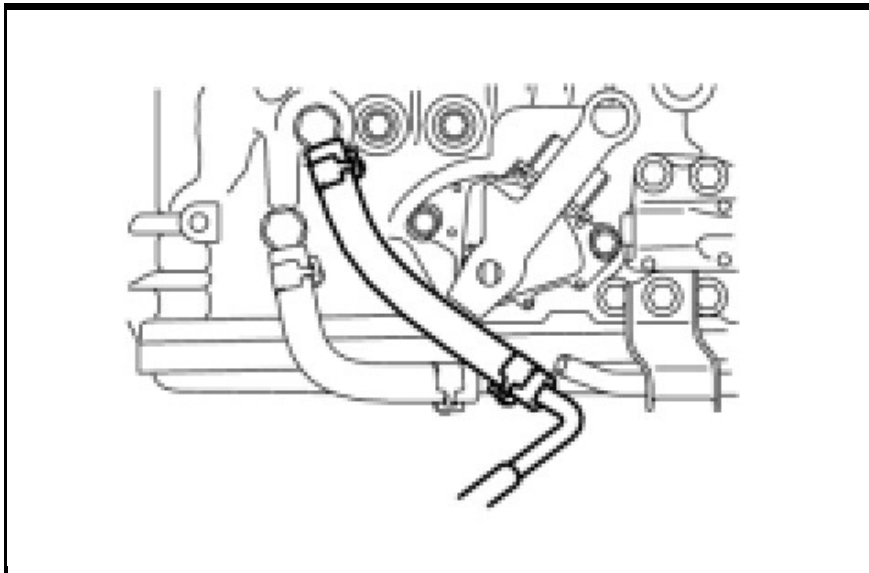

Zoom Sized for Print

(f) Add 1.1 liters (1.2 US qts, 1.0 Imp qts.) of ATF to the disconnected oil cooler hose.

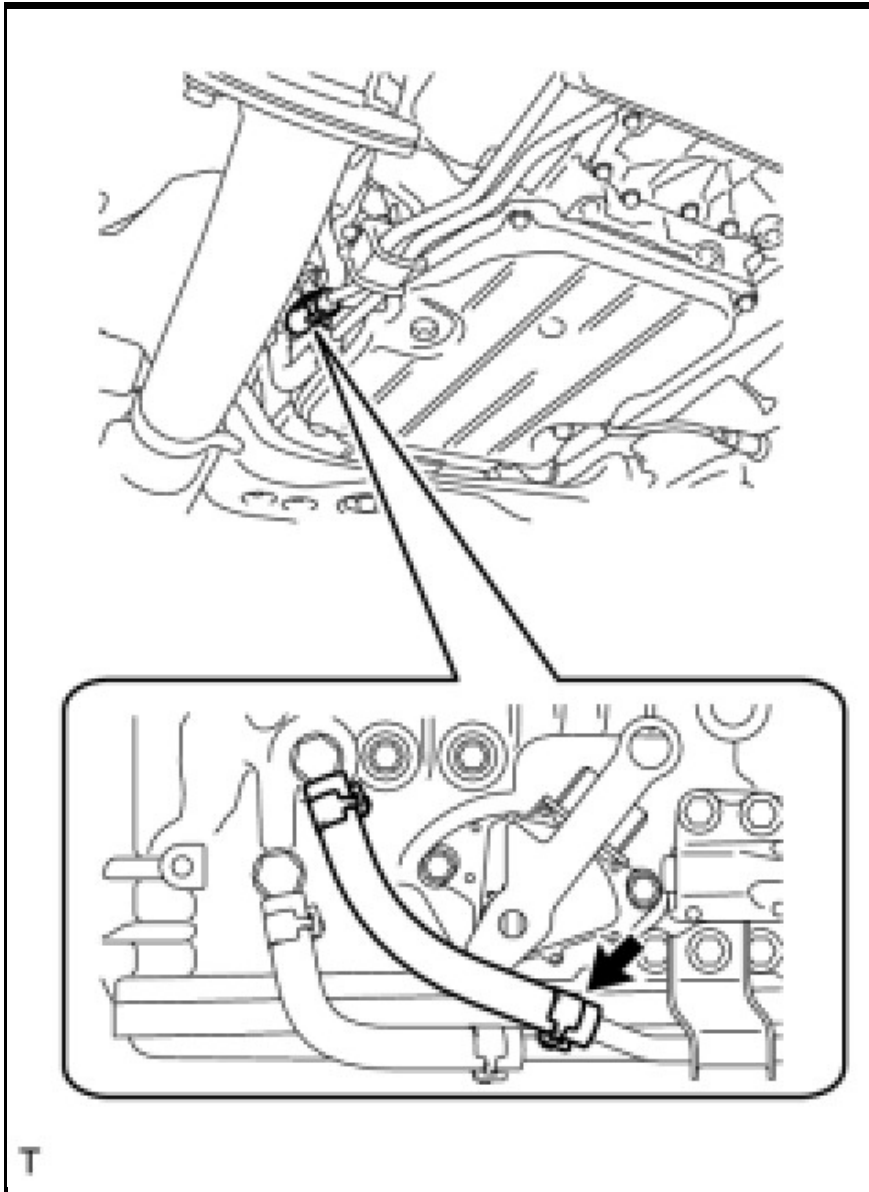

Zoom Sized for Print

(g) Connect the oil cooler hose.

NOTE: Be sure to adjust the fluid level after adding fluid.

4. PERFORM FLUID CIRCULATION

- (a) Allow the engine to idle with the air conditioning OFF.
- (b) Move the shift lever through the entire gear range to circulate fluid.
- (c) Allow the engine to idle until the fluid temperature reaches 30°C (86°F).

HINT: The fluid temperature should be less than 40°C (104°F) before starting the hybrid system.

5. CHECK FLUID LEVEL **NOTICE:**

- Do not touch any high temperature parts, such as the exhaust pipe, during the fluid level check. This is because the fluid level check is performed with the power switch on (READY).
- If turning the power switch on (READY) while the vehicle is lifted up, be sure to connect terminals 11 (OPA) and 4 (CG) of the DLC3. After performing the fluid level check, turn the power switch off or lower the vehicle down to the ground, and then disconnect the terminals.

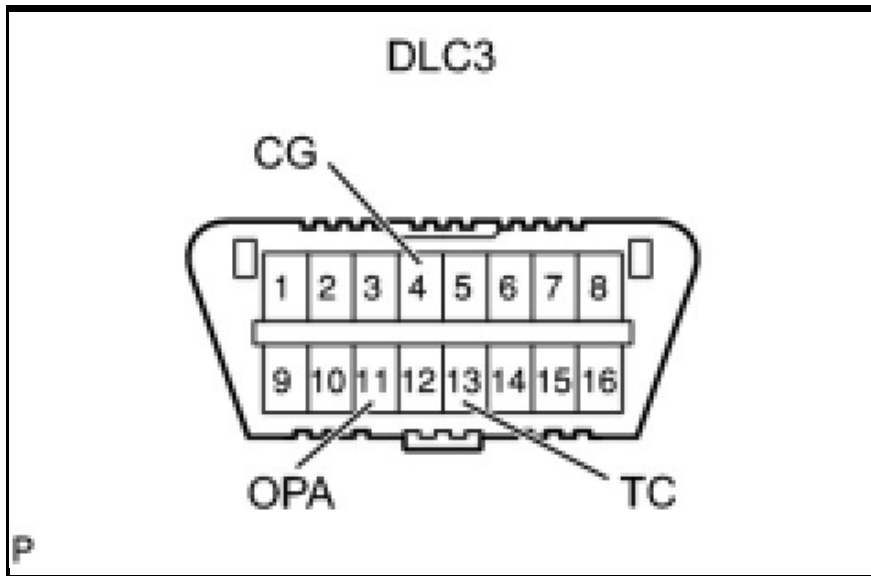

Zoom

Sized for Print

- (a) Using SST, connect terminals 13 (TC), 11 (OPA) and 4 (CG) of the DLC3.

SST: [09843-18040](#)

- (b) Turn the power switch on (READY).

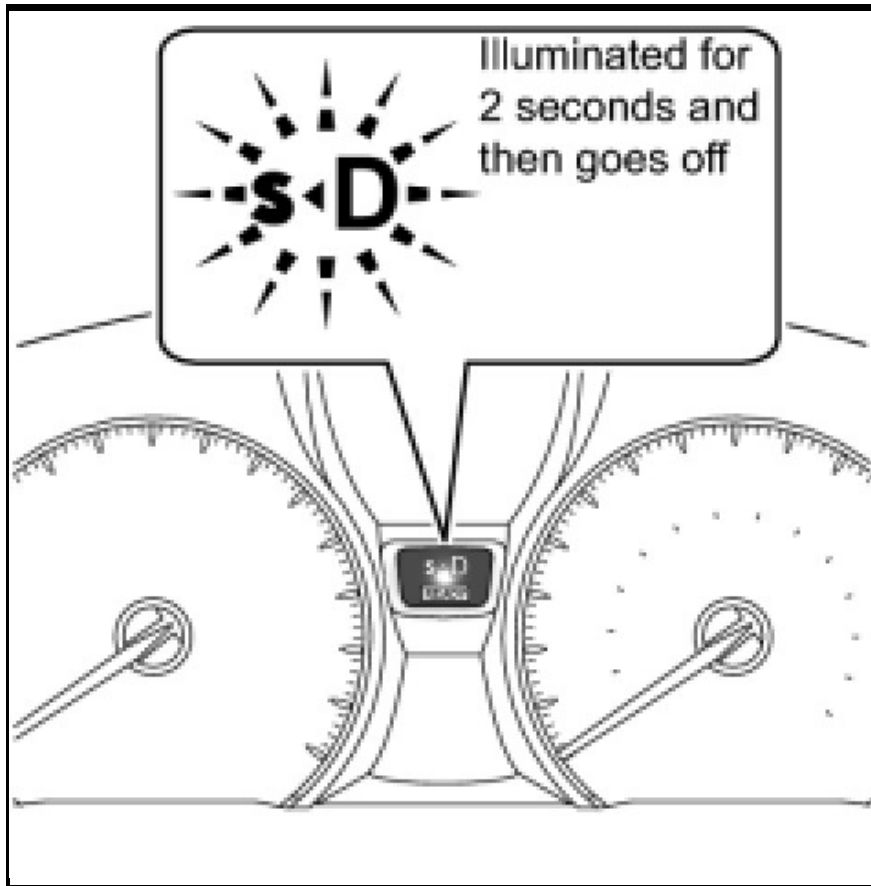

Zoom Sized for Print

- (c) Move the shift lever to the D position, and quickly move it back and forth between N and D at an interval of 1.5 seconds for 6 seconds or more. This will activate the fluid temperature detection mode.

Standard:

The indicator light (D) remains illuminated for 2 seconds and then goes off.

- (d) Return the shift lever to the P position and disconnect terminal 13 (TC).
- (e) Idle the engine to raise the temperature of the ATF.

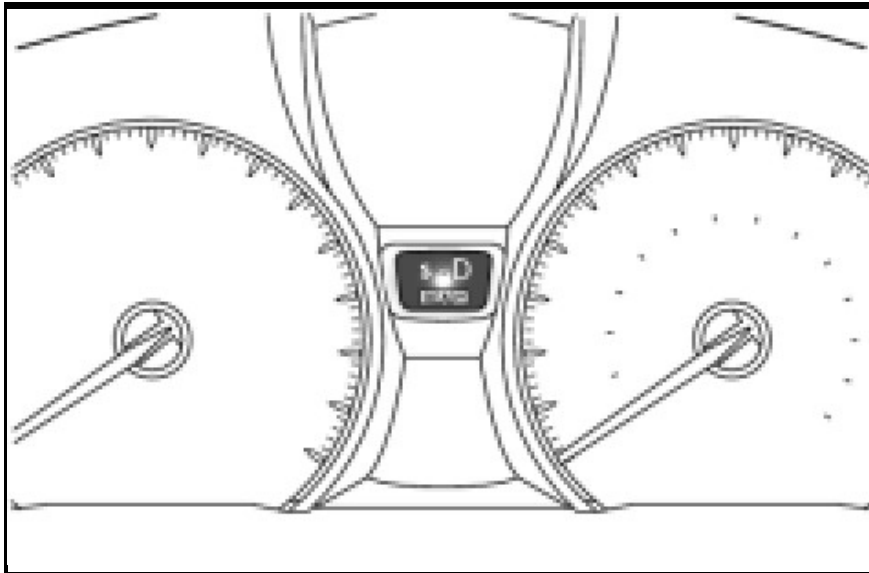

Zoom Sized for Print

(f) When the indicator light (D) turns on, lift the vehicle up immediately.

The **ATF** temperature range is indicated by the indicator light (D) as shown below:

Below Normal Operating Temperature	Normal Operating Temperature	Above Normal Operating Temperature
OFF	ON	Blinking

Zoom Sized for Print

NOTE: Perform fluid level inspection while the indicator light is on.

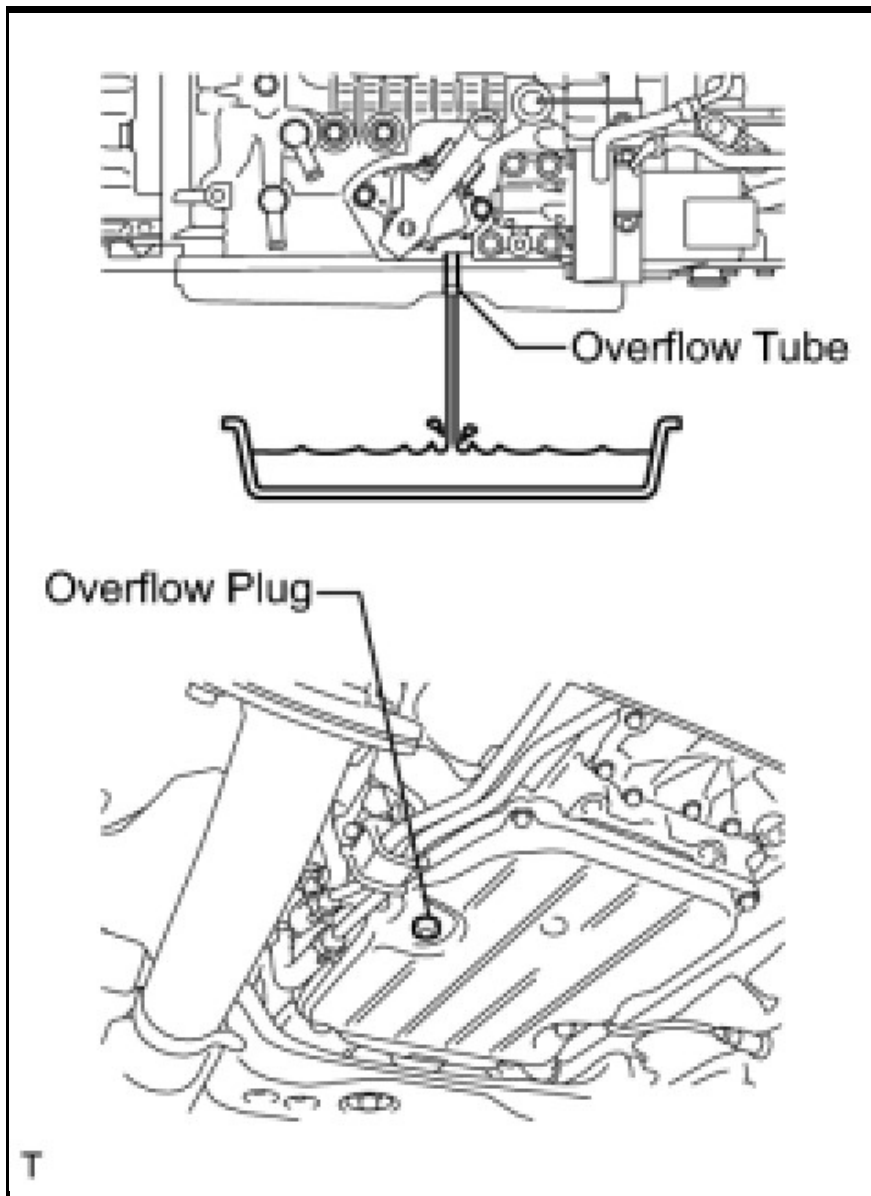

Zoom

Sized for Print

(g) Remove the overflow plug. At the proper fluid inspection temperature, check the fluid amount.

If the ATF flows from the overflow tube and the ATF flows in a thin stream, the fluid amount is normal.

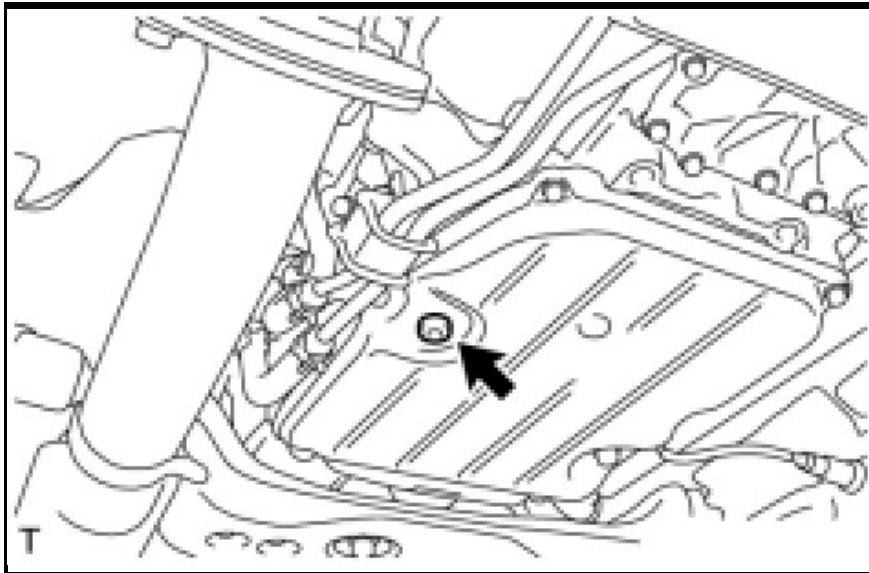

Zoom

Sized for Print

(h) Install a new gasket and the overflow plug.

Torque: 20 Nm (204 kgf-cm, 15 ft-lbf)

- (i) Install the front center floor cover [See: Engine, Cooling and Exhaust\Engine\Service and Repair\Removal and Replacement\Engine Assembly\Installation.](#)
- (j) Lower the vehicle.
- (k) Turn the power switch off.
- (l) Disconnect terminals 11 (OPA) and 4 (CG) of the DLC3.

[Account](#) | [Vehicle](#) | [Help](#) | [Contact](#) | [AutoZone Community](#) | [Exit](#)

© 2019 ALLDATA, LLC. All Rights Reserved. [Trademarks](#) | [Privacy Policy](#) | [Terms and Conditions](#)