

AA80E AUTOMATIC TRANSMISSION > AUTOMATIC TRANSMISSION FLUID > ADJUSTMENT

1. BEFORE REFILL TRANSMISSION

- This transmission requires Toyota Genuine ATF WS transmission fluid.
- After servicing the transmission, you must refill the transmission with the correct amount of fluid.
- Maintain the vehicle in a horizontal position while adjusting the fluid level.
- If the entire transmission, transmission pan, drain plug, valve body and/or torque converter is replaced, proceed to the "FILL TRANSMISSION PAN" procedures.
- If the transmission hose, extension housing oil seal and/or radiator is replaced and/or a repair of oil leak is performed, proceed to the "ADJUST FLUID LEVEL" procedures.

2. FILL TRANSMISSION PAN

- a. Lift the vehicle up while keeping a level state.
- b. Remove the refill plug and overflow plug.

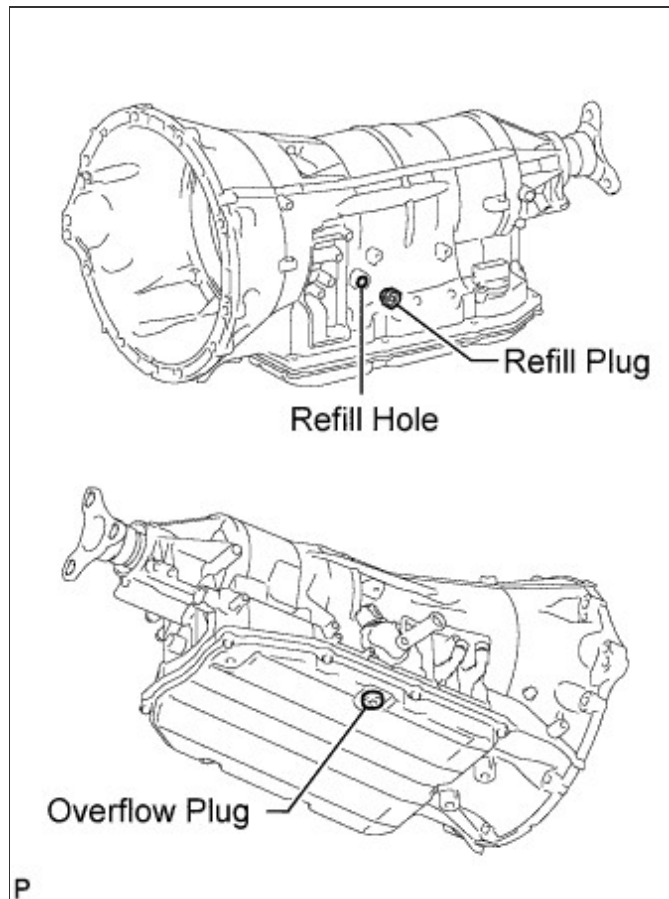

- c. Fill the transmission through the refill hole until fluid begins to trickle out from the overflow tube.
- d. Reinstall the overflow plug.

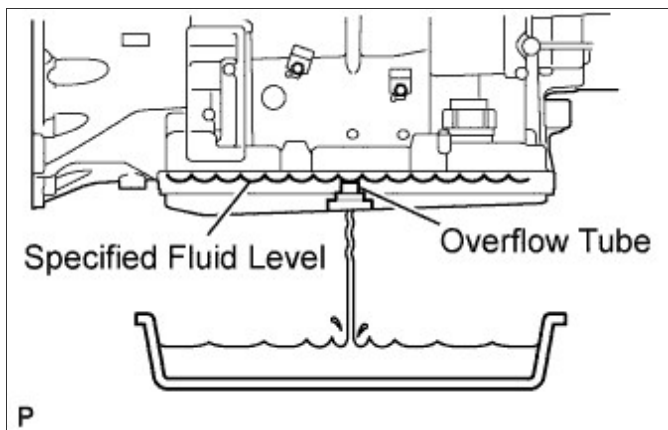

3. FILL TRANSMISSION

- a. Fill the transmission with the amount of fluid listed in the table below.

Standard capacity:

Repair	Specified Condition
Transmission pan and drain plug removal	3.2 liters (3.38 US qts, 2.82 Imp. qts)
Transmission valve body removal	4.2 liters (4.44 US qts, 3.70 Imp. qts)
Torque converter removal	6.7 liters (7.08 US qts, 5.90 Imp. qts)
Entire transmission assembly	9.9 liters (10.46 US qts, 8.71 Imp. qts)

- a. w/o Air Suspension:
Using SST, connect terminals 13 (TC) and 4 (CG) of the DLC3.

SST
09843-18040

- b. w/ Air Suspension:
Using SST, connect terminals 13 (TC), 11 (OPB) and 4 (CG) of the DLC3.

SST
09843-18040

- c. Start the engine.

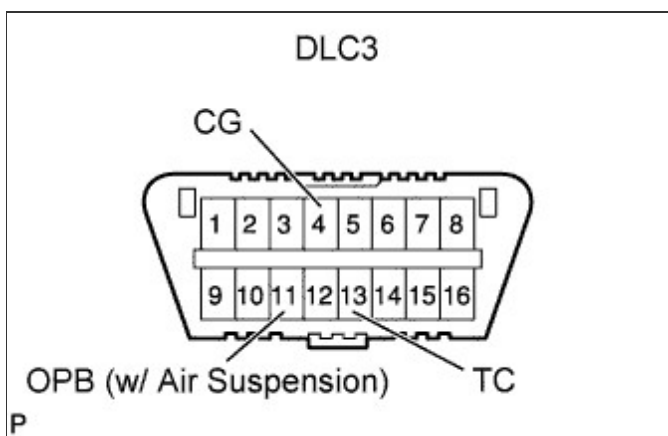

NOTICE:

Air conditioning switch must be turned off.

- d. Slowly move the shift lever from P to S, then move the shift lever from the 1 to 8. Then return the shift lever to P.

- e. Move the shift lever to the D position, and quickly move back and forth between N and D (once per less than 1.5 seconds) for at least 6 seconds. This will activate the fluid temperature detection mode.

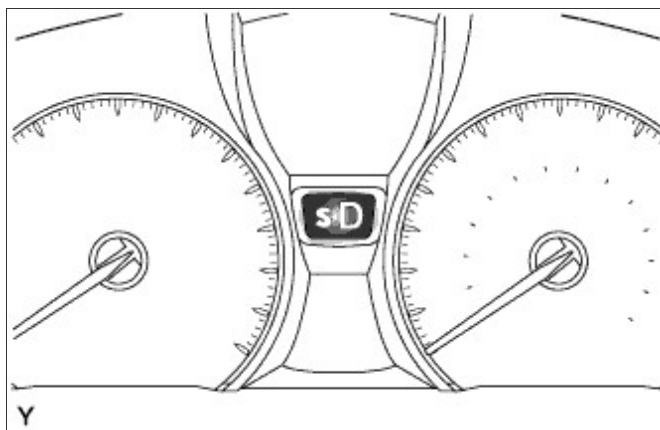

Standard:

Indicator light (D) remains illuminated for 2 seconds and then goes off.

- f. w/o Air Suspension:
Return the shift lever to the P position and disconnect terminals 13 (TC) and 4 (CG).
- g. w/ Air Suspension:
Return the shift lever to the P position and disconnect terminal 13 (TC).
- h. Idle the engine to raise the temperature of the ATF.

- i. When the indicator light (D) turns on, lift the vehicle up immediately.

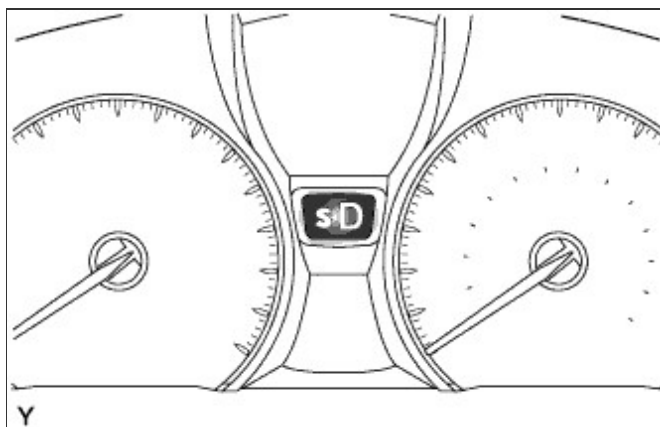

Indicator light will indicate the ATF temperature:

Lower than proper temp	Proper temp	Higher than proper temp
Turn off	Turn on	Blinking

NOTICE:

Perform fluid level inspection while the indicator light turns on.

- j. Remove the overflow plug. At the proper fluid inspection temperature, check the fluid amount. If the ATF flows from the overflow tube and the ATF flows in a thin stream, the fluid amount is normal. If the ATF does not flow from the overflow tube, add ATF into the refill hole until ATF flows from the overflow tube. If the ATF flows in a thin stream, the fluid amount is normal.
- k. Install a new gasket and the overflow plug.

Torque:

**20 N*m{ 204 kgf*cm , 15
ft.*lbf }**

- l.** Install a new O-ring and the refill plug.

Torque:

**39 N*m{ 398 kgf*cm , 29
ft.*lbf }**

- m.** Lower the vehicle down.
- n.** Turn the engine switch off.
- o.** w/ Air Suspension:
Disconnect the terminals 11 (OPB)
and 4 (CG) of the DLC3.

