

CHARGING SYSTEM

ON-VEHICLE INSPECTION

CH043-04

CAUTION:

- Check that the battery cables are connected to the correct terminals.
- Disconnect the battery cables when the battery is given a quick charge.
- Do not do tests with a high voltage insulation resistance tester.
- Never disconnect the battery while the engine is running.

1. CHECK BATTERY ELECTROLYTE LEVEL

Check the electrolyte quantity of each cell.

Maintenance-free Battery:

If under the lower level, replace the battery (or add distilled water if possible). Check the charging system.

Except Maintenance-free Battery:

If under the lower level, add distilled water.

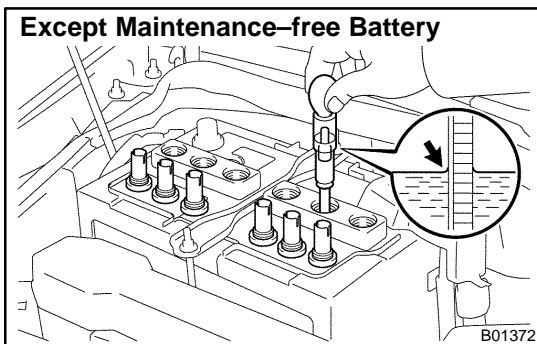

2. Except Maintenance-free Battery: CHECK BATTERY SPECIFIC GRAVITY

Check the specific gravity of each cell.

Standard specific gravity: 1.25 – 1.29 at 20°C (68°F)

If the specific gravity is less than specification, charge the battery.

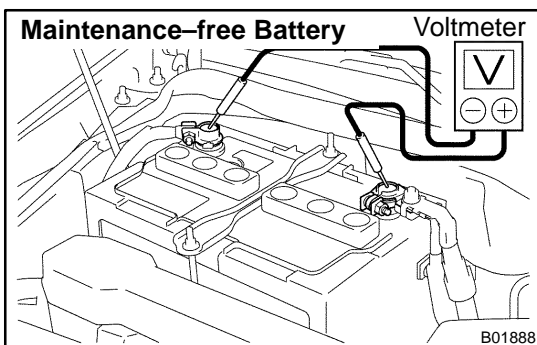

3. Maintenance-free Battery: CHECK BATTERY POSITIVE VOLTAGE

- After having driven the vehicle and in the case that 20 minutes have not passed after having stopped the engine, turn the ignition switch ON and turn on the electrical system (headlight, blower motor, rear defogger etc.) for 60 seconds to remove the surface charge.
- Turn the ignition switch OFF and turn off the electrical systems.
- Measure the battery positive voltage between the negative (–) and positive (+) terminals of the battery.

Standard voltage: 12.5 – 12.9 V at 20°C (68°F)

If the voltage is less than specification, charge the battery.

4. CHECK BATTERY TERMINALS AND FUSES

- Check that the battery terminals are not loose or corroded.

If the terminals are corroded, clean the terminals.

- Check the fusible link and fuses for continuity.

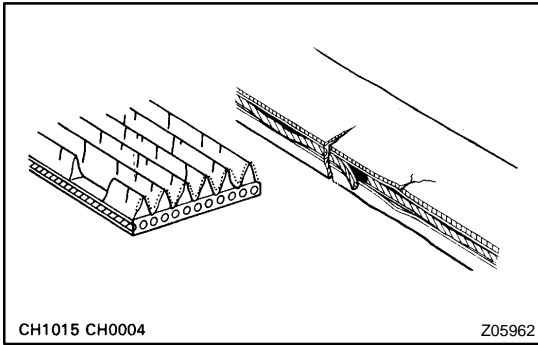

5. INSPECT DRIVE BELT

- (a) Visually check the drive belt for excessive wear, frayed cords, etc.

If necessary, replace the drive belt.

HINT:

- Cracks on the rib side of a drive belt are considered acceptable. If the drive belt has chunks missing from the ribs, it should be replaced.

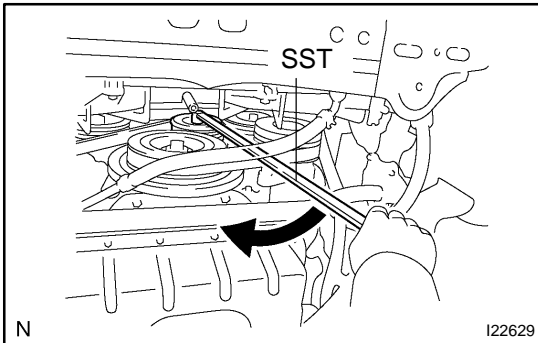

- (b) Check the belt tensioner operation.

- Remove the engine under cover.
- Using SST, the drive belt tension can be released by turning the belt tensioner clockwise from the bottom side.

SST 09216-00041

- Install the engine under cover.

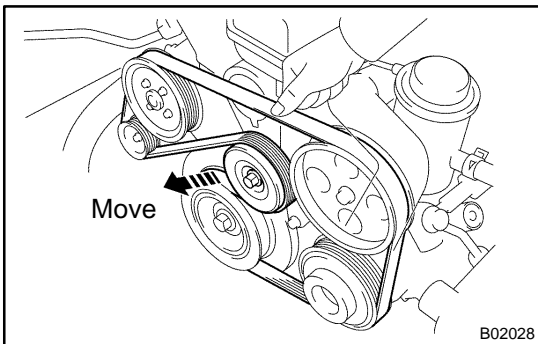

- Check that the belt tensioner moves downward when the drive belt is pressed down at the points indicated in the illustration with approx. 98 N (10 kgf, 22.0 lbf) of force.

- Check the alignment of the belt tensioner pulley to make sure the drive belt will not slip off the pulley.

If necessary, replace the belt tensioner.

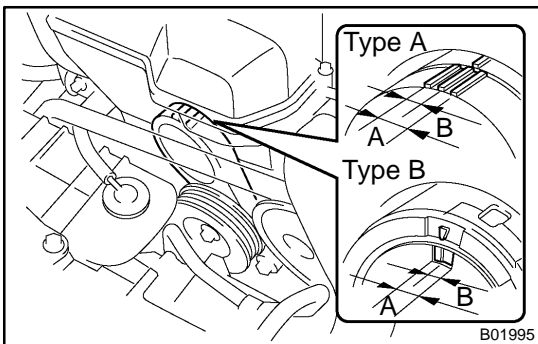

- Check that the arrow mark on the belt tensioner falls within area A of the scale.

If it is outside area A, replace the drive belt.

HINT:

- When a new belt is installed, it should lie within area B. If not, the drive belt is not correct.

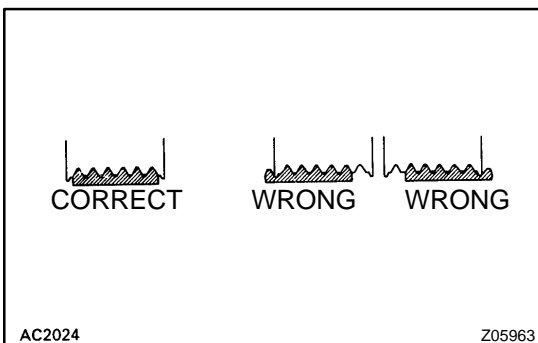

- After installing a drive belt, check that it fits properly in the ribbed grooves.
- Check by hand to confirm that the belt has not slipped out of the groove on the bottom of the pulley.

6. VISUALLY CHECK GENERATOR WIRING AND LISTEN FOR ABNORMAL NOISES

- Check that the wiring is in good condition.
- Check that there is no abnormal noise from the generator while the engine is running.

7. CHECK CHARGE WARNING LIGHT CIRCUIT

- (a) Warm up the engine and then turn it off.
 - (b) Turn off all accessories.
 - (c) Turn the ignition switch "ON". Check that the charge warning light is lit.
 - (d) Start the engine. Check that the light goes off.
- If the light does not go off as specified, troubleshoot the charge light circuit.

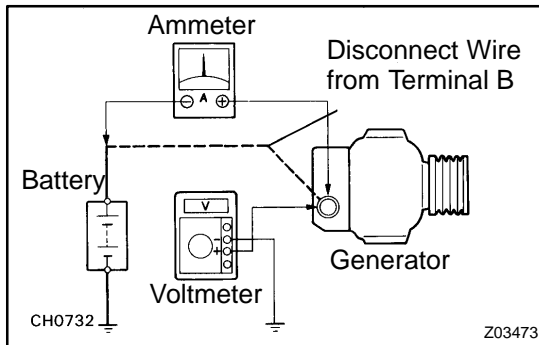
**8. INSPECT CHARGING CIRCUIT WITHOUT LOAD****HINT:**

If a battery/generator tester is available, connect the tester to the charging circuit as per manufacturer's instructions.

- (a) If a tester is not available, connect a voltmeter and ammeter to the charging circuit as follows:
 - Disconnect the wire from terminal B of the generator, and connect it to the negative (–) probe of the ammeter.
 - Connect the positive (+) probe of the ammeter to terminal B of the generator.
 - Connect the positive (+) probe of the voltmeter to terminal B of the generator.
 - Ground the negative (–) probe of the voltmeter.
- (b) Check the charging circuit as follows:
With the engine running from idling to 2,000 rpm, check the reading on the ammeter and voltmeter.

Standard amperage: 10 A or less

Standard voltage: 13.2 – 14.8 V

If the voltmeter reading is more than standard voltage, replace the voltage regulator.

If the voltmeter reading is less than standard voltage, check the voltage regulator (See page [CH-9](#)).

9. INSPECT CHARGING CIRCUIT WITH LOAD

- (a) With the engine running at 2,000 rpm, turn on the high beam headlights and place the heater blower switch at "HI".
- (b) Check the reading on the ammeter.

Standard amperage: 30 A or more

If the ammeter reading is less than the standard amperage, repair the generator.

HINT:

If the battery is fully charged, the indication will sometimes be less than standard amperage.