



**Technical Service
Information Bulletin**

May 23, 2006

Title:
FRONT SEAT SQUEAK NOISE

Models:
'04 – '07 Lexus

NVH
NV001-06

Introduction Some customers may experience a squeak noise due to contact between the seat track locating pin(s) and the floor pan location hole(s). The following procedure describes the repair method to correct this condition.

- Applicable Vehicles**
- **2004 – 2007** model year **Lexus** vehicles.

**Required
Tools &
Material**

TOOLS & MATERIAL	QUANTITY
Flat Blade Screwdriver (Taped Tip)	1
Power Cut-off Tool (or equivalent)	1

**Warranty
Information**

OP CODE	DESCRIPTION	TIME	OFF	T1	T2
NV5011	R & R Front Seat Track Pins (1 seat)	0.5	72011-#####	91	99
Combo A	Opposite Side	0.5	72012-#####		

Applicable Warranty*:

This repair is covered under the Lexus Comprehensive Warranty. This warranty is in effect for 48 months or 50,000 miles, whichever occurs first, from the vehicle's in-service date.

* Warranty application is limited to correction of a problem based upon a customer's specific complaint.



Pin Location The following table indicates the location and the number of seat track locating pins that should be removed from the seat track assembly:

MODEL	NUMBER OF PINS TO REMOVE	PIN LOCATION
ES (All Models)	2	Front, Inner, & Outer Track
GS (All Models)	2	Front, Inner, & Outer Track
GX (All Models)	2	Front, Inner, & Outer Track
IS (All Models)	2	Front, Inner, & Outer Track
LS 430	2	Front, Inner, & Outer Track
LX (All Models)	2	Front, Inner, & Outer Track
RX (All Models)	1 (Inner Side ONLY)	Front & Inner Track ONLY
SC 430	2	Front, Inner, & Outer Track

Parts Location

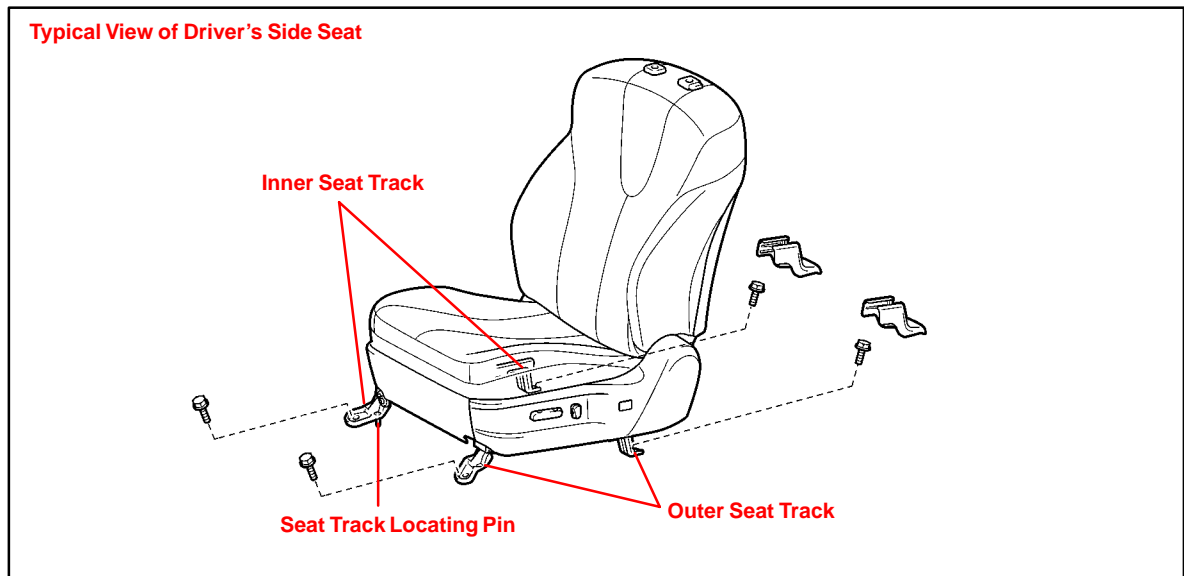

Repair Procedure

CAUTION:

- Wear safety gloves to prevent injury to your hands.
- Work must be started more than 90 seconds after the ignition switch is turned to the LOCK position and the negative (–) terminal cable is disconnected from the battery. (The SRS is equipped with a backup power source. If work is started within 90 seconds from disconnecting the negative (–) terminal cable of the battery, the SRS may deploy.)
- The yaw rate sensor is installed under the front RH seat. Be careful NOT to step on the yaw rate sensor after the seat has been removed.

HINT:

- The installation is the reverse order of removal. However, when there is a special point concerning installation, it is indicated.
- Use the same procedure on the RH side as on the LH side.
- When removing/installing and performing repairs on the passenger seat, perform the Occupant Classification System Zero Point Calibration as outlined in the Diagnostics section of the applicable model year Repair Manual for each model.

1. Disconnect the negative (–) battery terminal.
2. Remove the plastic front seat track covers — Use a screwdriver to disengage the claws and **carefully** remove the plastic seat track covers.

NOTE:

Tape the screwdriver tip before use.

Typical Outer Seat Track Cover

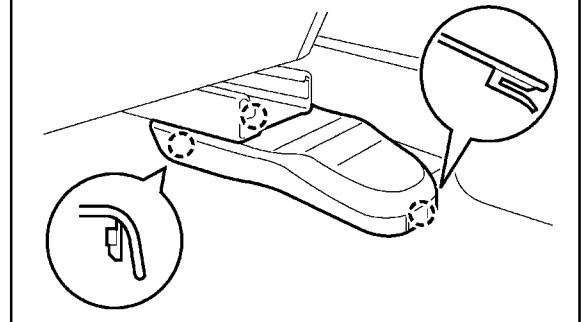

NOTE:

Refer to the appropriate Lexus Repair Manual for each model for detailed instructions on how to remove the plastic seat track covers.

Typical Inner Seat Track Cover

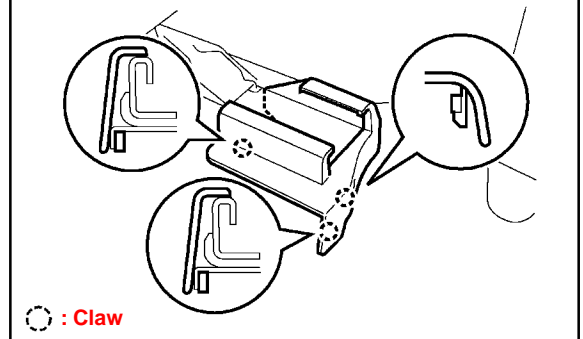

Repair Procedure
(Continued)

3. Remove the plastic rear seat track covers — Use the taped screwdriver to disengage the claws and **carefully** remove the plastic seat track covers.
4. Remove the LH front seat assembly.
 - A. Move the seatback to the full upright position.
 - B. Remove the four (4) seat track securing bolts.
 - C. Disconnect the electrical connectors and remove the complete seat assembly.
5. Remove the seat track locating pins.
 - A. With the seat removed from the vehicle, tilt the seat assembly backward to gain access to the seat track locating pins.
 - B. Use a power cut-off tool (or equivalent) to cut off the two (2) locating pins leaving 2 mm (0.1in.) or less of each pin.

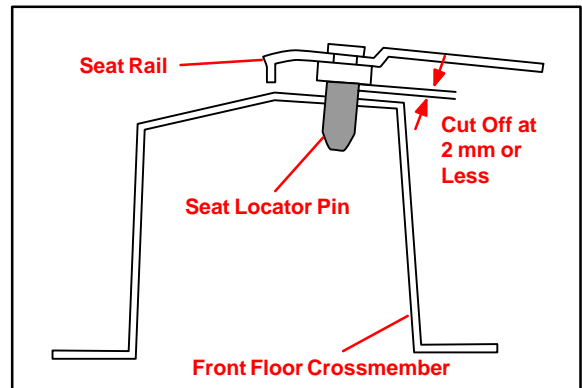
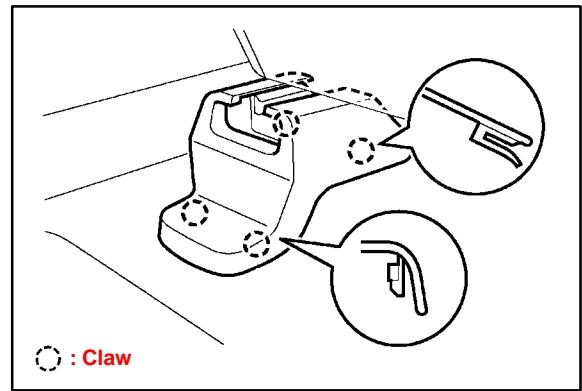

CAUTION:

Do NOT permit the power cut-off tool to contact the seat track. ONLY cut off the shaft of the pin (near the base of the seat track).

NOTE:

The seat track locating pins' function is to ease installation during manufacturing and does NOT provide any other function.

6. Clean and paint bare metal surfaces.
 - A. Remove any metal shavings from the seat track/seat assembly.
 - B. Clean the bare metal surface of the remainder of the seat track locating pin with wax, grease, and silicone remover.
 - C. To prevent corrosion, coat any bare metal surfaces still attached to the seat track with a brush-on type paint.
7. Install LH front seat assembly.
 - A. Place the seat on the cabin floor.
 - B. Reconnect all electrical connectors under the seat.
 - C. Install all four (4) seat track retaining bolts (fingertight).

**Repair
Procedure**
(Continued)

D. Tighten the two (2) front seat track attaching bolts.

NOTE:

The bolt torque specification varies by model. Please refer to the Repair Manual for the correct bolt torque for the model you are working on.

E. Tighten the 2 rear seat track attaching bolts.

NOTE:

The bolt torque specification varies by model. Please refer to the Repair Manual for the correct bolt torque for the model you are working on.

F. Reinstall all plastic seat track covers.

8. Repeat steps 1 – 6 for the RH seat assembly.
9. Reconnect the negative (–) battery terminal.
10. Test power seat operation and seat heater (if equipped) for proper operation.
11. Initialize front passenger occupant classification system and re-initialize any other power systems.
 - Refer to TSIB No. PD010-05, “*Power System Initialization During PDS.*”
 - Refer to TSIB No. PD009-06, “*Power System Initialization During PDS.*”
12. Inspect SRS warning light operation.
13. Test drive vehicle and confirm that the seat squeak has been eliminated.