

**Part Number: Tuner Assy 86180-0W030  
Mounting Kit 86100-0W220**

**NOTE:** Part number of this accessory may not be the same as the part number shown.

**Tuner Assy Kit Contents (86180-0W030)**

Item #	Quantity Req.	Description
1	1	TUNER ASSY, STEREO COMPONENT

**Mounting Kit Contents (86100-0W220)**

Item #	Quantity Req.	Description
1	1	Wire, To Radio Installation
2	1	Bracket, Radio Receiver

**Hardware Bag Contents 1 (86100-0W220)**

Item #	Quantity Req.	Description
1	3	Cushion Tape (50mm×100mm)
2	3	Tie Wrap
3	1	Ground Cable

**Hardware Bag Contents 2 (86100-0W220)**

Item #	Quantity Req.	Description
1	4	Screw (M5×L8)

**Additional Items Required For Installation**

Item #	Quantity Req.	Description

**Conflicts**

iPod Interface, Sirius Satellite Radio
--

**Recommended Tools**

Personal & Vehicle Protection	Notes
Vehicle Protection	Clean Cloths, Part Boxes
Special Tools	Notes
None	
Installation Tools	Notes
Panel Clip Removal Tool	e.g. Toyota SST P/N:- 00002-06002-01
Socket	10mm
Screwdriver	Phillips, #2
Wrench	Open End, 10mm
Torque Wrench	36 lbf · in
Side Cutter	
Special Chemicals	Notes
None	

**General Applicability**

--

**Recommended Sequence of Application**

Item #	Accessory

\*Mandatory

**Vehicle Service Parts** (may be required for reassembly)

Item #	Quantity Req.	Description

**Legend**

 **STOP:** Damage to the vehicle may occur. Do not proceed until process has been complied with.

 **OPERATOR SAFETY:** Use caution to avoid risk of injury.

 **CAUTION:** A process that must be carefully observed in order to reduce the risk of damage to the accessory/vehicle.

 **TOOLS & EQUIPMENT:** Used in Figures calls out the specific tools and equipment recommended for this process.

 **REVISION MARK:** This mark highlights a change in installation with respect to previous issue.

 **SAFETY TORQUE:** This mark indicates that torque is related to safety.

Parts Description of Tuner Assy (86180-0W030)

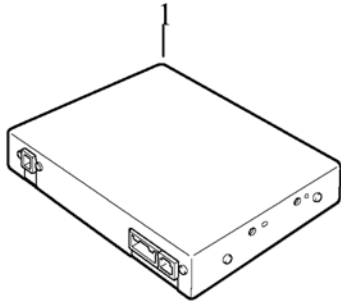

Item #	Parts Name	Parts No.	Qty
1	TUNER ASSY, STEREO COMPONENT ★	86180-0W030	1

★ In the installation instructions and figures, this is referred to as “Tuner”.

Parts Description of Mounting Kit (86100-0W220)

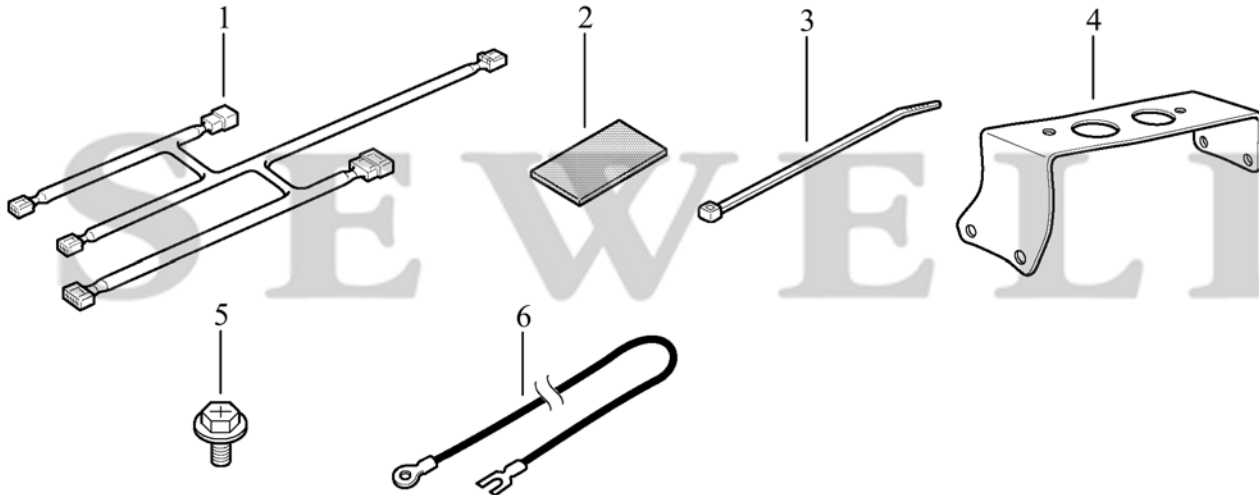

Item #	Parts Name	Parts No.	Qty
1	Wire, To Radio Installation ★1	82372-0W070	1
2	Cushion Tape (50mm×100mm)	—	3
3	Tie Wrap	—	3
4	Bracket, Radio Receiver ★2	86215-0W130	1
5	Screw (M5×L8)	90153-50010	4
6	Ground Cable	—	1

★ 1 In the installation instructions and figures, this is referred to as “Tuner Cable”.

★ 2 In the installation instructions and figures, this is referred to as “Tuner Bracket”.

Care must be taken when installing this accessory to ensure damage does not occur to the vehicle. The installation of this accessory should follow approved guidelines to ensure a quality installation.

These guidelines can be found in the "Accessory Installation Practices" document.

This document covers such items as:-

- Vehicle Protection (use of covers and blankets, cleaning chemicals, etc.).
- Safety (eye protection, rechecking torque procedure, etc.).
- Vehicle Disassembly/Reassembly (panel removal, part storage, etc.).
- Electrical Component Disassembly/Reassembly (battery disconnection, connector removal, etc.).

Please see your Lexus dealer for a copy of this document.

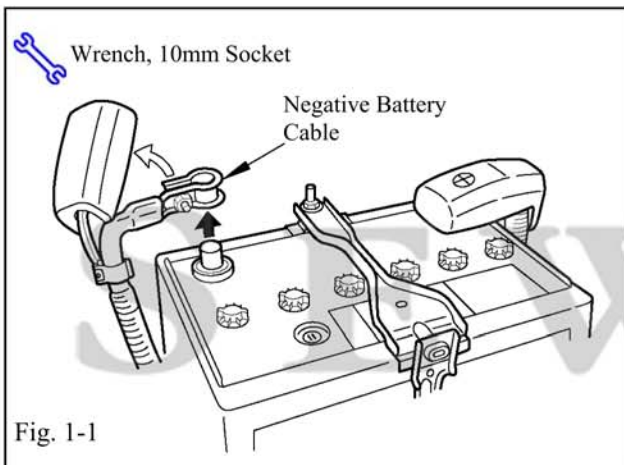

### 1. Vehicle Protection

- (a) Set emergency hand brake.
- (b) Remove the negative battery cable (Fig. 1-1).
  - (1) Protect the fender before starting.
  - (2) Do not touch the positive terminal with any tool when removing cable.
- (c) Wait 90 seconds before proceeding to disassemble vehicle.

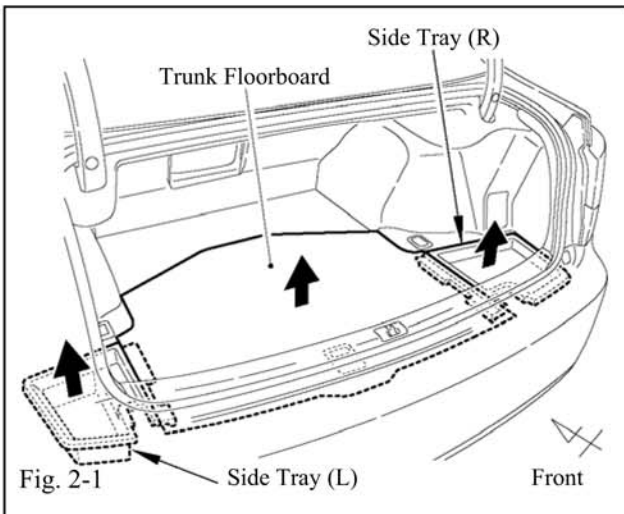

### 2. Disassembly of Vehicle

- STOP** NOTE: Place all removed parts on a protected surface.
  - STOP** NOTE: When disconnecting wiring connectors do not pull on the wiring, pull on the connector only.
- (a) Remove the trunk floorboard (Fig. 2-1).
  - (b) Remove the side tray (R/L) (Fig. 2-1).

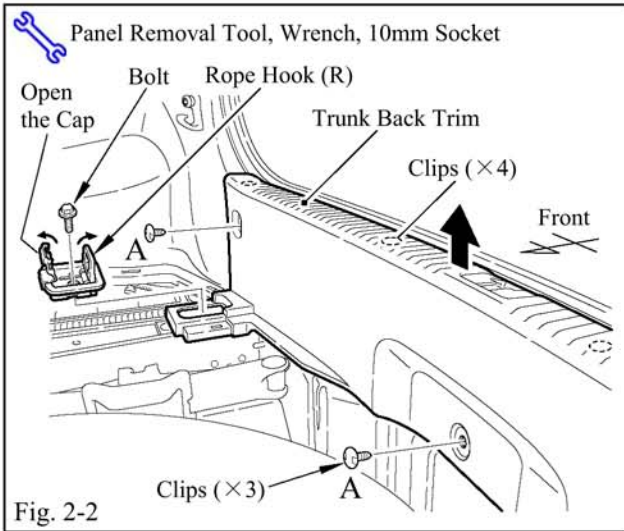

Fig. 2-2

(c) Remove the trunk back trim (Fig. 2-2).

**NOTE:** The right side is shown in the figure, but the procedure is the same for the left side.

- (1) Remove the bolt, and then remove the rope hook (R/L).
- (2) Remove clips "A" .
- (3) Pull the trim in the direction of the arrow, and remove clips.

(d) Remove the trunk center trim (Fig. 2-3).

**NOTE:** The right side is shown in the figure, but the procedure is the same for the left side.

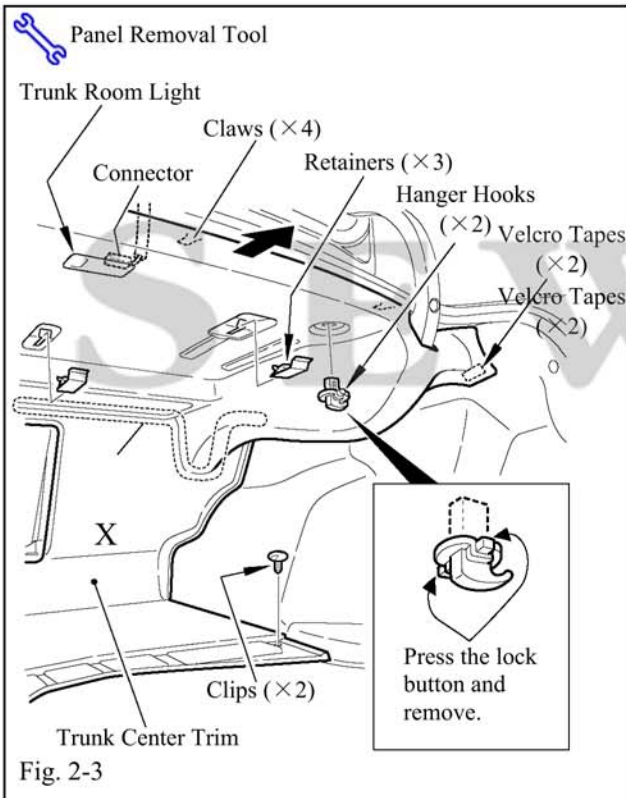

Fig. 2-3

- (1) Remove retainers from the upper section.
- (2) Remove hanger hooks from the upper section.
- (3) Remove clips from the floor section.
- (4) Pull the upper edge of the trim towards you, and remove claws.
- (5) Disconnect the trunk room light connector.



**NOTE:** When taking out the trim from the trunk room, be careful that the staple holding the trim (indicated with an X in the figure) does not come out.

### 3. Tuner installation

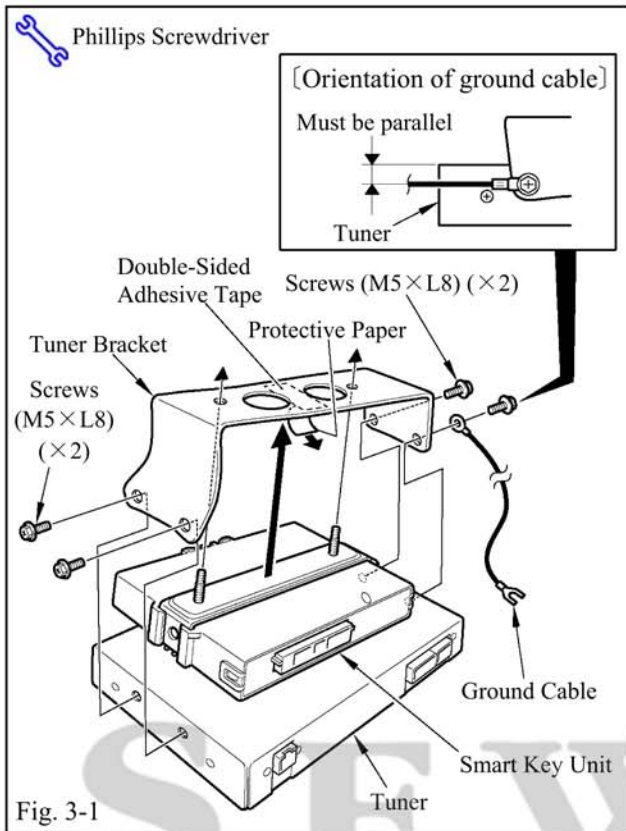

(a) Assemble the tuner and Smart Key Unit (Fig. 3-1).

- (1) Peel off the protective paper of the double-sided adhesive tape adhered to the tuner bracket.
- (2) Insert the bolts of the Smart Key Unit into the holes in the tuner bracket, and affix the Smart Key Unit to the tuner bracket.
- (3) Attach the tuner bracket and ground cable to the tuner.

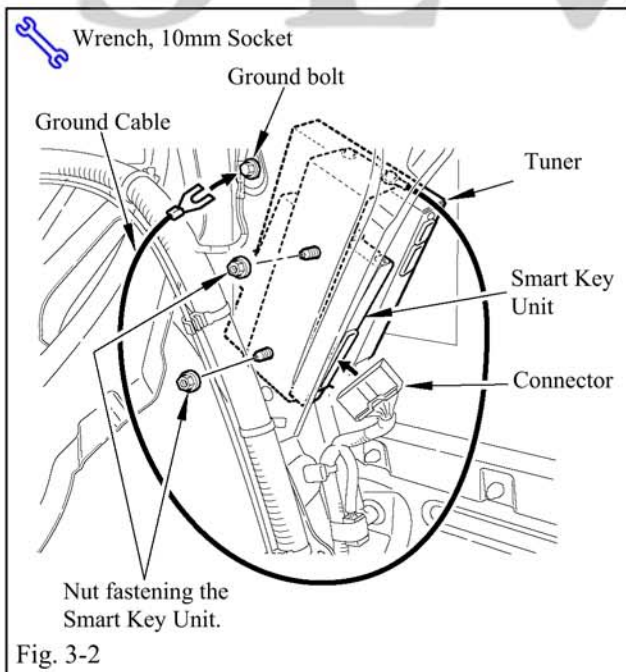

(b) Attach the tuner and Smart Key Unit to the side panel with nuts (Fig. 3-2).

**+** **NOTE :** Be careful not to pinch your fingers between the side panel and Smart Key Unit or between the tuner and Smart Key Unit when tightening the nuts.

- (c) Fasten the ground cable with the bolt shown in the figure (Fig. 3-2).
- (d) Reconnect the wiring connector of the Smart Key Unit (Fig. 3-2)

#### 4. Tuner cable and Antenna cable Wiring

**NOTE :** The indications in the figure are for a standard audio amp but they are the same for Mark Levinson audio amp .

- (a) Remove the amp harness from the amp (Fig. 4-1).

**NOTE :** The 10P connectors (2 locations) are removed to facilitate connection of the tuner cable (Fig. 4-3).

- (b) Connect the tuner cable to the amp harness and the harness shown in the figure (Fig. 4-1).

- (c) Wrap cushion tape around locations where the connector is connected (Fig. 4-2).

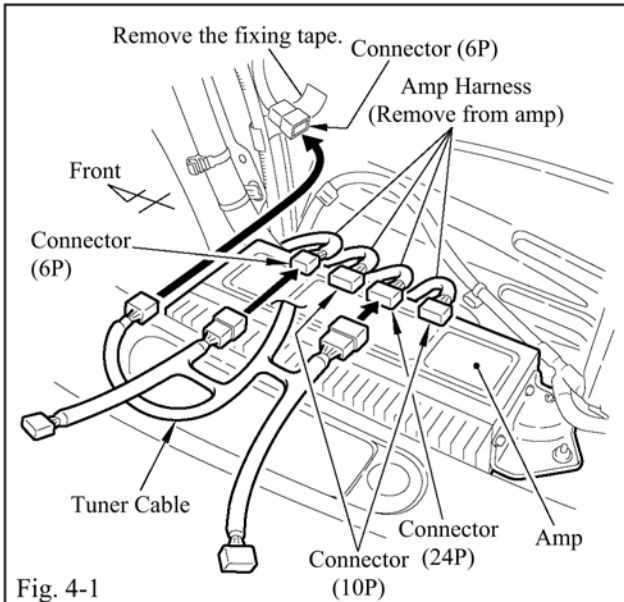

Fig. 4-1

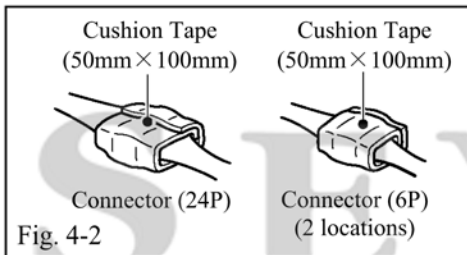

Fig. 4-2

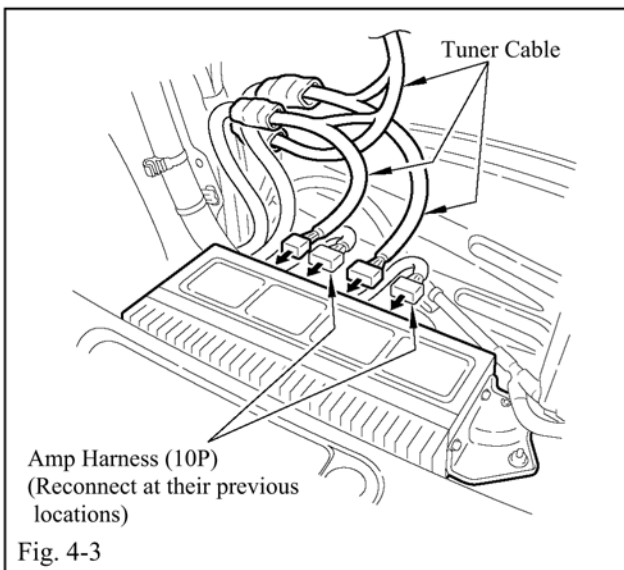

Fig. 4-3

- (d) Connect the tuner cable and amp harness to the amp (Fig. 4-3).

**NOTE :** Connect in order starting with the connector on the front side to facilitate connection work.



Side Cutter

For models with standard audio amp

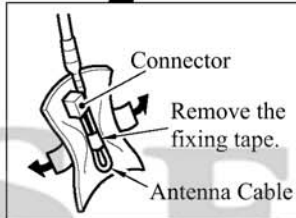
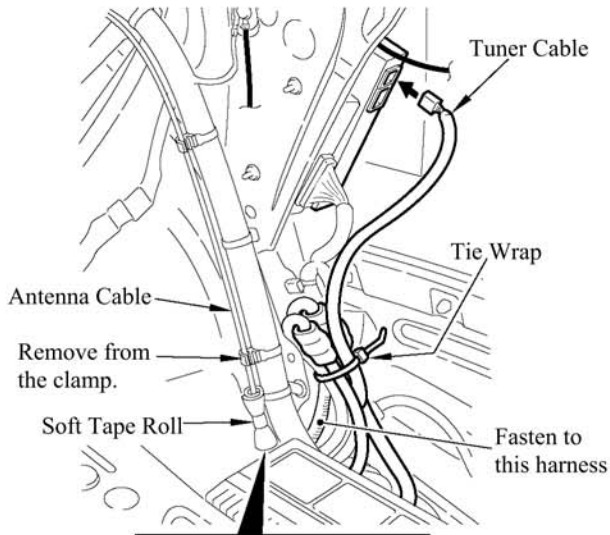

Fig. 4-4

For models with Mark Levinson audio amp

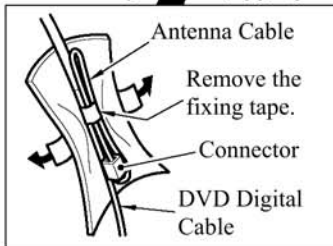
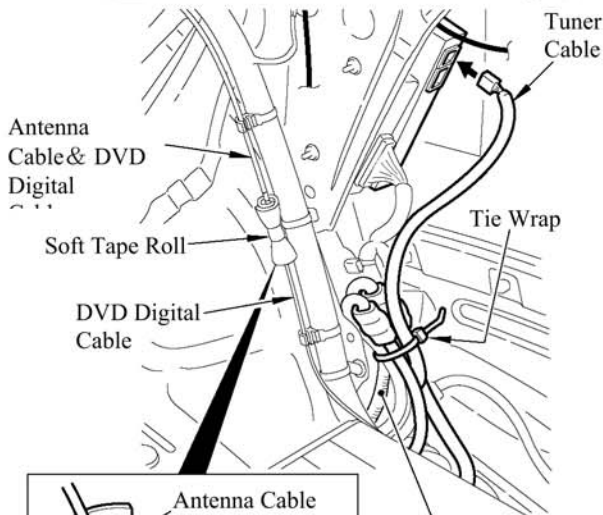
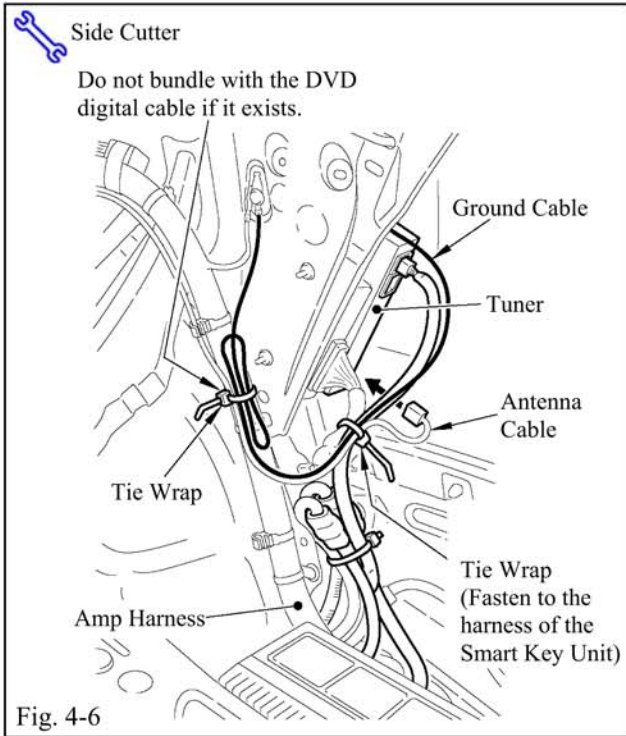

Fig. 4-5

- (e) Connect the tuner cable to the amp (Fig. 4-4, 4-5).
- (f) Bundle up any excess cable and fasten to the harness shown in the figure with a tie wrap (Fig. 4-4, 4-5).
- (g) Cut off excess tie wrap with a side cutter.
- (h) Unbind the soft tape roll at the tip of the antenna cable, and then remove the fixing tape of the antenna cable (Fig. 4-4, 4-5).



- (i) Connect the antenna cable to the tuner (Fig. 4-6).
- (j) Bundle up the excess antenna cable and ground cable and fasten with tie wraps at the locations shown on the amp harness (Fig. 4-6).
- (k) Fasten the ground cable, antenna cable and tuner cable to the harness of the Smart Key Unit with a tie wrap (Fig. 4-6).
- (l) Cut off excess tie wrap with a side cutter.

## 5. Completing the installation

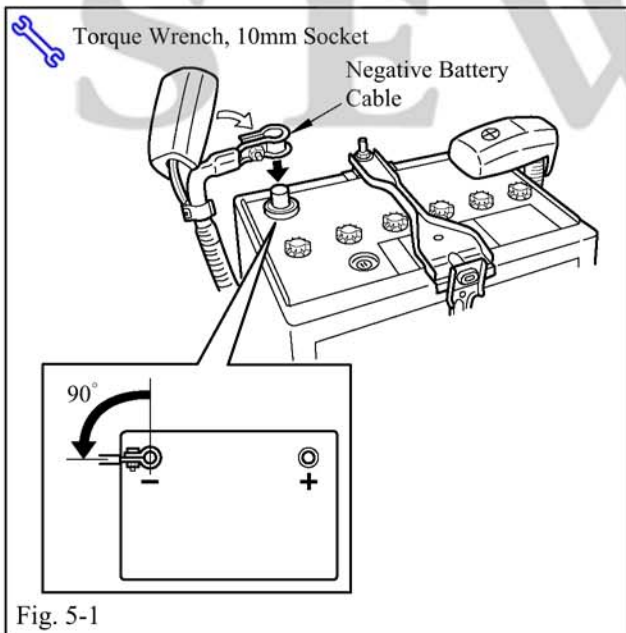

- (a) Complete the reassembly of the vehicle.
  - (1) Reconnect any disconnected connectors.
  - (2) Verify the panels fit together properly with no uneven gaps between them.
- (b) Clean up and remove any trash.
- (c) Reconnect the vehicle's negative battery cable (Fig. 5-1).
  - (1) Position the negative terminal at an angle of 90° to the battery as shown in inset.
  - (2) Tighten the nut to 4.1N•m (36 lbf•in).
  - (3) Do not touch the positive terminal with any tool when replacing the cable.





Check:

Look For:

Accessory Function Checks

- Verify the proper operation of the satellite radio tuner referring to the receiver assy and radio owner's manuals.
- Verify the proper operation of the receiver assy and radio referring to the receiver assy and radio owner's manuals.

Vehicle Function Checks

- Trunk Room Light
- Smart Key
- There is the one for which the initialization of the vehicle function parts is necessary after restoring the battery cable. Please do the initialization work referring to vehicle repair book RM03D0U.

Functioning Trunk Room Light

Functioning Smart Key

