

Part Number: 08154-53830

Kit Contents

Item #	Quantity Reqd.	Description
1	1	Front bumper ground effects
2	1	Hardware bag
3	2	Instruction manual

Hardware Bag Contents

Item #	Quantity Reqd.	Description
1	4	Plastic retainer cup
2		

Additional Items Required For Installation

Item #	Quantity Reqd.	Description
1		
2		

Conflicts

None

Recommended Tools

Personal & Vehicle Protection	Notes
Safety goggles	
Special Tools	Notes
Installation Tools	Notes
Drill	Variable
Drill bit	1/8", 7/16" hole saw
Screwdriver	Phillips, Flat head
Panel Removal Tool	
File or straight flute reamer	
Ratchet	
Socket & Extension	10 mm deep well
Scriber	
Low tack masking tape	
Air gun	
Lint-free cloth	
Special Chemicals	Notes
Windex	

General Applicability

--

NOTE: Part number of this accessory may not be the same as the part number shown.

Recommended Sequence of Application

Item #	Accessory
1	
2	
3	

*Mandatory

Vehicle Service Parts (may be required for reassembly)

Item #	Quantity Reqd.	Description
1		
2		
3		

Legend

 **STOP:** Damage to the vehicle may occur. Do not proceed until process has been complied with.

 **OPERATOR SAFETY:** Use caution to avoid risk of injury.

 **CAUTION:** A process that must be carefully observed in order to reduce the risk of damage to the accessory/vehicle and to ensure a quality installation.

 **TOOLS & EQUIPMENT:** Used in Figures calls out the specific tools and equipment recommended for this process.

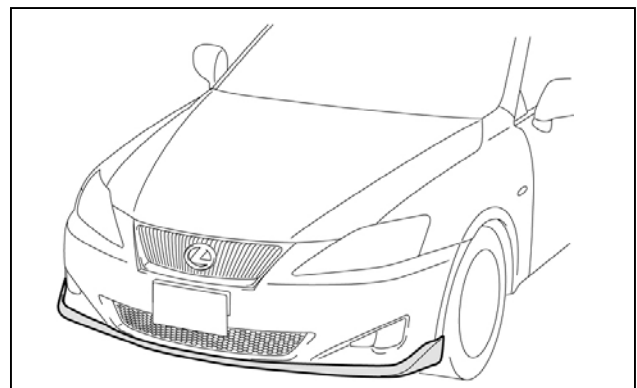

Care must be taken when installing this accessory to ensure damage does not occur to the vehicle. The installation of this accessory should follow approved guidelines to ensure a quality installation.

These guidelines can be found in the "Accessory Installation Practices" document.

This document covers such items as:-

- Vehicle Protection (use of covers and blankets, cleaning chemicals, etc.).
- Safety (eye protection, rechecking torque procedure, etc.).
- Vehicle Disassembly/Reassembly (panel removal, part storage, etc.).
- Electrical Component Disassembly/Reassembly (battery disconnection, connector removal, etc.).

Please see your Toyota dealer for a copy of this document.

1. Protecting Vehicle Parts.

- (a) To protect the area from scratches, affix masking tape to the headlight and the parting area between the fender panel and the bumper. (Fig. 1-1)

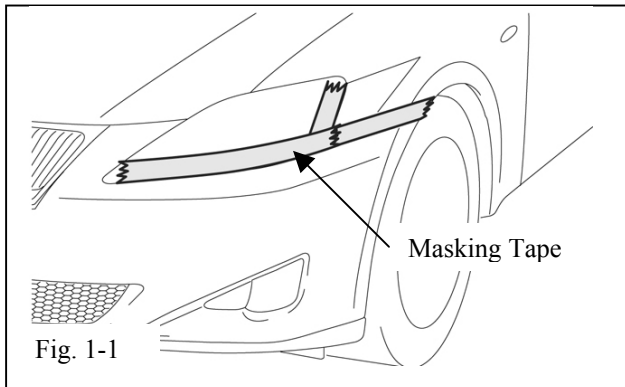

2. Removing the Front Bumper Spoiler.

-  This procedure is only necessary if the factory spoiler has previously been installed during PDS.

- (a) Remove the nine tapping screws and two clips. (Fig. 2-1)
- (b) Detach the ten tabs and remove the front bumper ground effect. (Fig. 2-1)

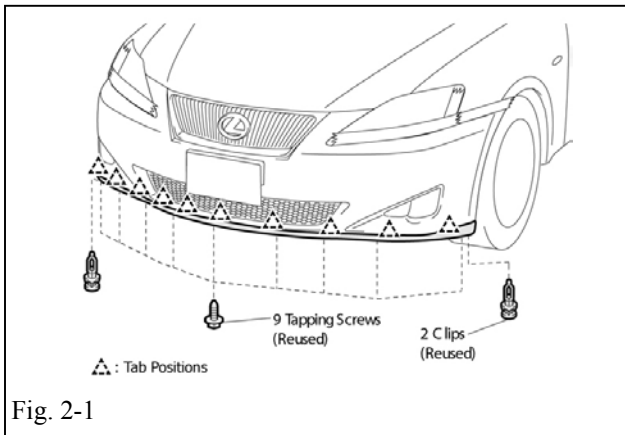

3. Preparing the Front Bumper Ground Effect.

 Perform steps (a), (b), and (c) below only if front spoiler was not installed during PDS.

(a) Remove factory front spoiler from trunk, open package, and remove fasteners (1 tapping screw, 1 spring nut, and 2 plastic clips).

(b) Discard factory front spoiler.

(c) Using front ground effects from accessory kit, use side cutters to remove tabs as shown in Figure 3-1.

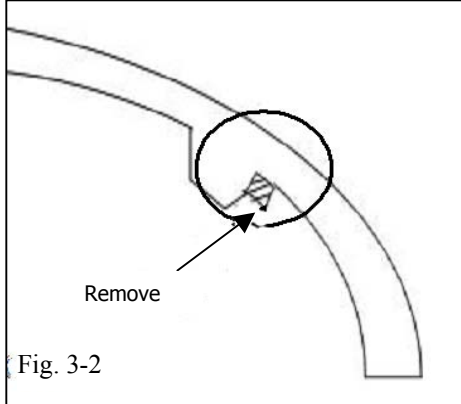
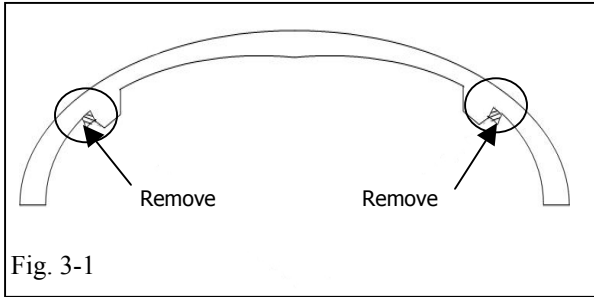

 Only remove the portion indicated by hash marks. (Fig. 3-2)

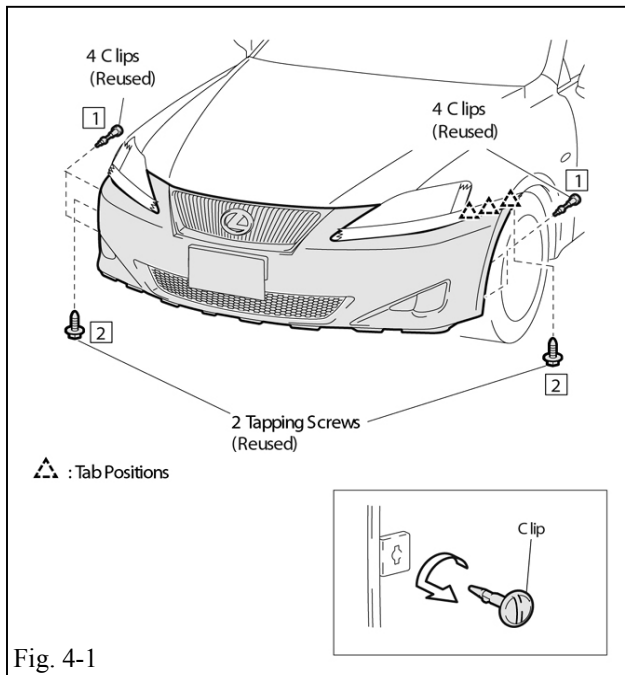





Fig. 4-1

4. Parts Removal.

- (a) Remove the four clips from the arch and two tapping screws in the order of [1] and [2] as shown. (Fig. 4-1)

 At the wheel arch, turn the clips 90° before pulling them out.

 Do not misplace the parts that you have removed from the vehicle because you will be reusing them.

- (b) Detach the tabs at the three areas marked  (RH and LH).

5. Processing of the Front Bumper.

- (a) Drill Holes in Front Bumper Cover

- (1) Locate the marking on the backside of the bumper. (Fig. 5-1).

- (2) Place marks on the three marking points behind the front bumper cover by fully inserting a push pin into the centers of those points. (Fig. 5-1)

 When placing the marks with a push pin, insert the push pin perpendicularly to the bumper surface. Be sure the pin penetrates through the bumper material.

 To check the marking position easily, illuminate the inside of the bumper with a work light.

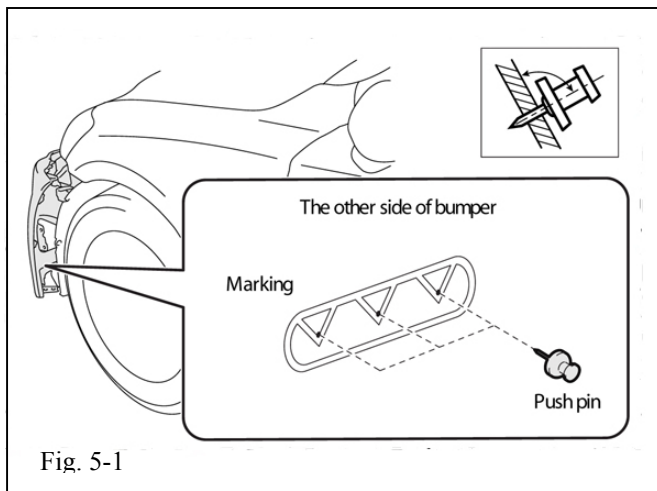

Fig. 5-1

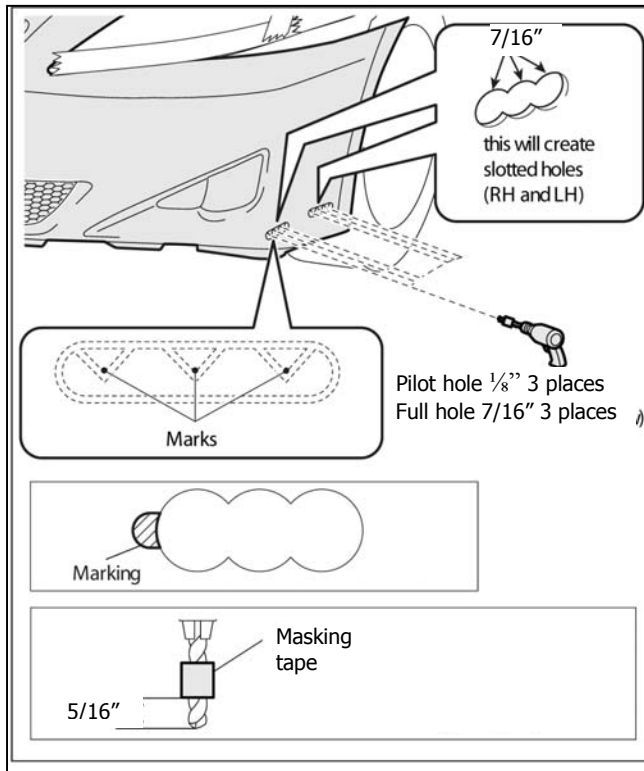

Fig. 5-2

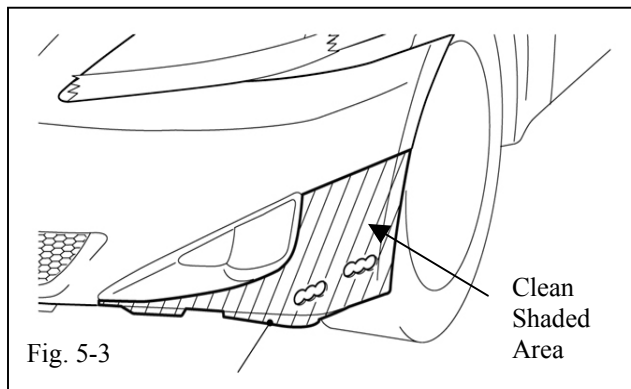

Fig. 5-3

- (3) Drill three 1/8" pilot holes at the six locations that you have marked with the pin. (Fig. 5-2)
- (4) Using a 7/16" hole saw, drill over the six holes (this will create two slotted holes).
- (5) Use a small file to remove burrs from the holes.
- (6) Repeat the operation on the RH side in the same manner.
 - (1) To protect the front bumper cover and other parts from scratches while making the holes, wrap masking tape, which acts as a stop, around the drill at the positions shown in Figure 5-2).
 - (2) If the marks remain after the holes have been made, use a small file to enlarge the holes.

(b) Clean the front bumper. (Fig. 5-3)

- (1) Use Windex to clean the hatched area.
- (2) Repeat the operation on the RH side in the same manner.



NOTE: After cleaning the areas, do not touch them.

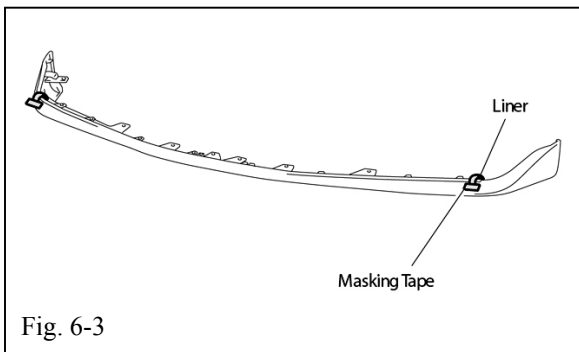
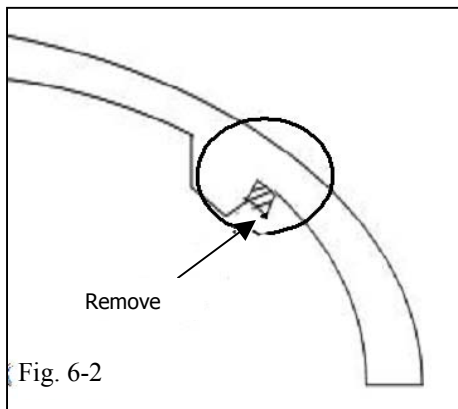
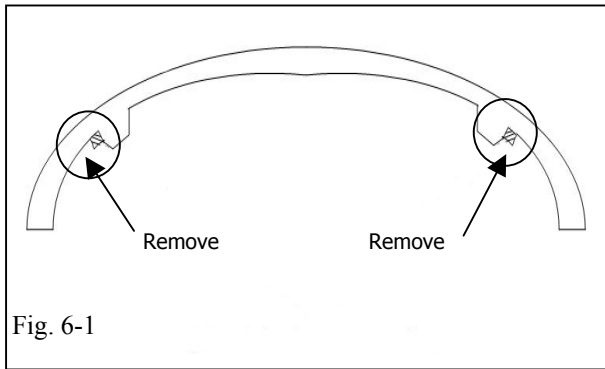

6. Installing the Front Bumper Ground Effects.

- (a) Remove factory front spoiler from trunk, open package, and remove fasteners (1 tapping screw, 1 spring nut, and 2 plastic clips).
- (b) Discard factory front spoiler.
- (c) Using front ground effects from accessory kit, use side cutters to remove tabs as shown in Figure 6-1.

 Only remove the portion indicated by the hash marks within the circles. (Fig. 6-2)

- (d) Dispose of liners.
 - (1) Peel the two liners from the adhesive tape on the front bumper ground effects, about 1 inch from the inner side of vehicle, and secure them with masking tape. (Fig. 6-3)

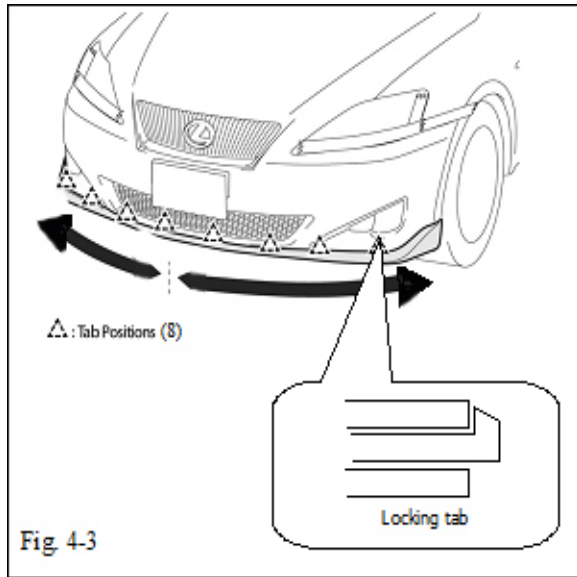

- (e) Temporarily install front bumper ground effects.
 - (1) Starting from the center of vehicle and working toward the outside, install the front bumper ground effects and engage the eight tabs. (Fig. 6-4)
 - (2) Use two hands and with fingers and thumbs, squeeze ground effect into bumper until locking tab is engaged.
- !** When engaging the tabs, be sure that the locking tab is fully engaged and secure.

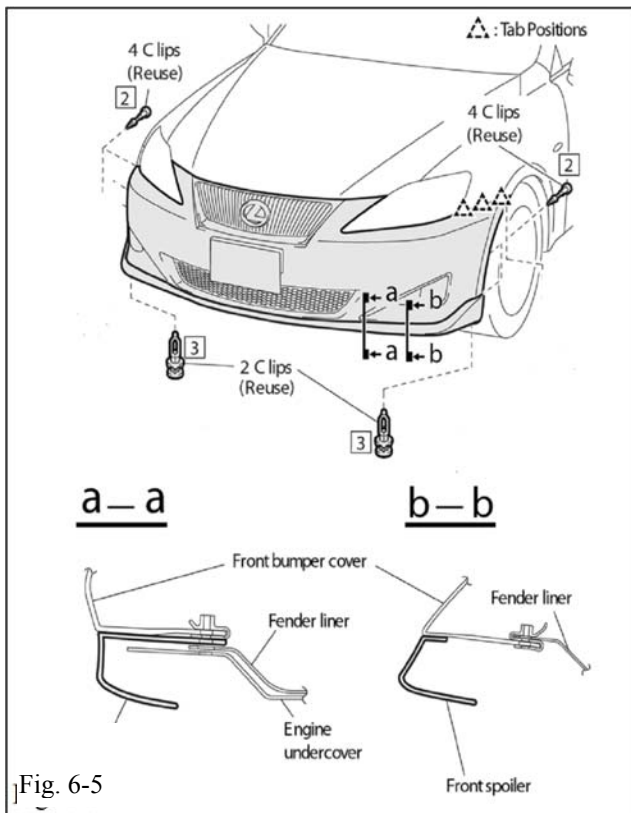

- (f) Install the front bumper ground effects.
 - (1) Using the cross section in the illustration as a reference, check the vertical position of the fender liner and the engine undercover. (Fig. 6-5)
 - (2) Engage the eight tabs of the front bumper cover, which were previously removed. (Fig. 6-5)
 - (3) Install the two tapping screws and six clips that were removed, in the order shown in figures [1] through [3]. (Fig. 6-5)
 - (4) Install the 1 spring nut to the front bumper cover (PDS instruction – PD041-05).

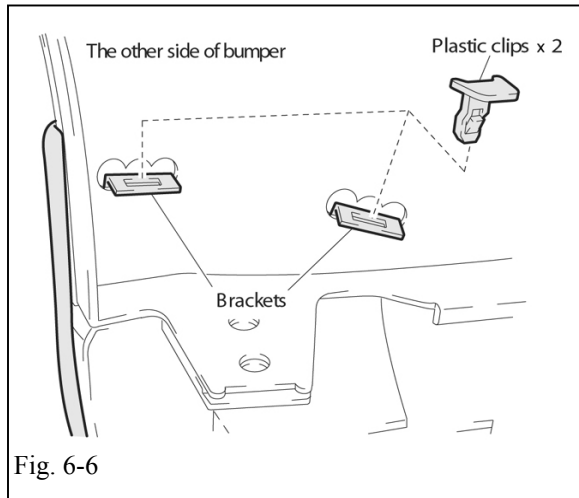

(g) Install the plastic clip.

(1) Pull the side of the front bumper cover outward of the vehicle, and insert the two plastic clips to the bracket. (Fig. 5-5)



(2) Be sure clips are properly installed and locked in position.

(3) Repeat the operation on the RH side in the same manner.

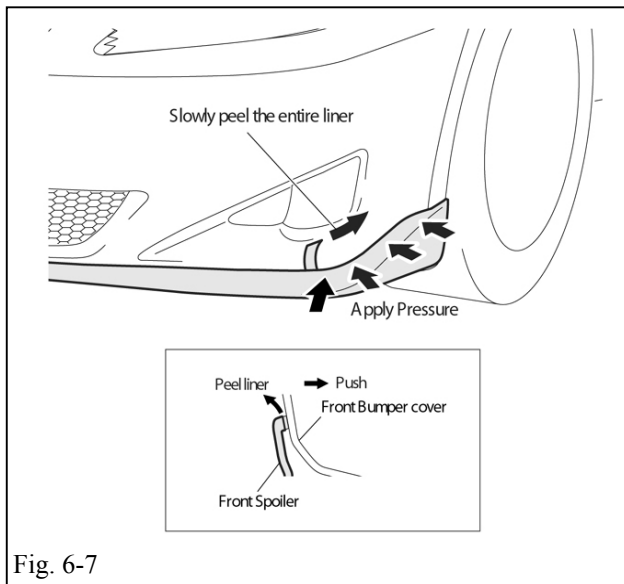

(h) Peel the liner from the adhesive tape of the front spoiler in the direction shown and affix the adhesive tape. Repeat the operation on the RH side in the same manner. (Fig. 6-7)

(1) Pull the liner while pushing on the front bumper cover without allowing the liner to tear in the middle. (Fig. 6-7)

(2) Apply pressure to affix the adhesive tape. Otherwise the adhesive tape could come lose and create a gap. (Fig. 6-7)

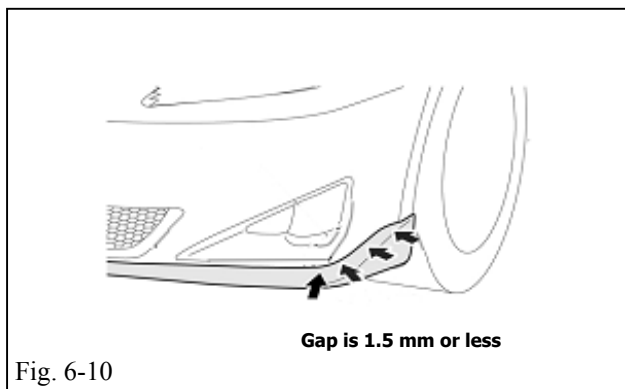
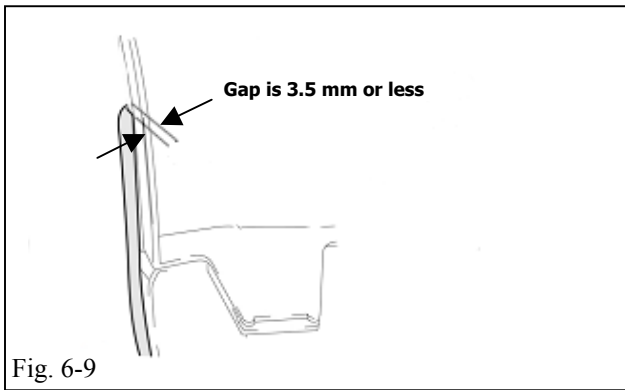
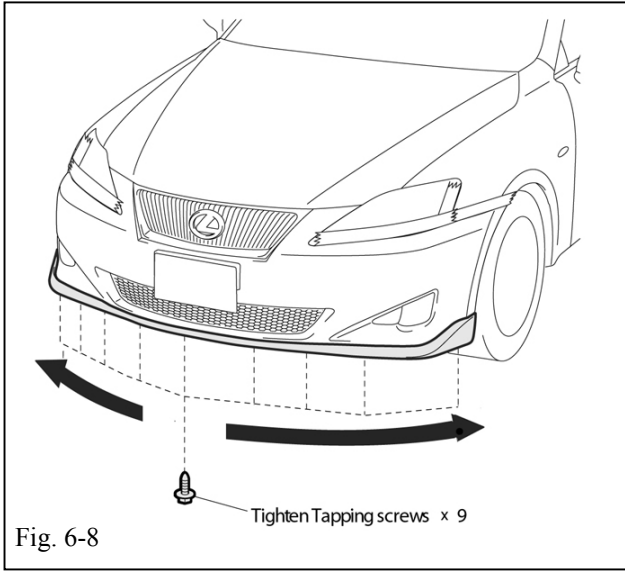

(i) Fully tighten the front bumper ground effects.

(1) Using nine tapping screws, fully tighten the temporarily chamfered portions on the front bumper ground effects and the front bumper cover from the inside toward the outside of the vehicle. (Fig. 6-8)

(2) Confirm that gap is 3.5 mm or less as shown in Fig. 6-9.

(3) Confirm that gap is 1.5 mm or less as shown in Fig. 6-10.

(4) Clean front bumper with Windex.

Checklist - these points **MUST** be checked to ensure a quality installation.

Check:

Look For:

Accessory Function Checks

- Front bumper ground effects

- Backing sheets and adhesive tapes

- Front bumper ground effects appearance

- Gap tolerance

Check that the front bumper ground effects is secured with bolts.

Check that all the backing sheets are removed from the adhesive tapes, and that the adhesive tapes are affixed securely.

Check that the front bumper ground effects and the vehicle parts did not get scratched during the installation.

Check that gaps are within specification of 1.5 mm and 3.5 mm or less.