

TECHNICAL INSTRUCTIONS

FOR

SAFETY RECALL ELF

FUEL PRESSURE SENSOR GASKET

CERTAIN

2006 - 2010 MY IS 250 (4GR-FSE Engine)

2010 MY IS 250C (4GR-FSE Engine)

All dealership associates involved in the campaign process are required to successfully complete E-Learning course SC13A. To ensure that all vehicles have the repair performed correctly; technicians performing this recall repair are required to currently hold at least one of the following certifications levels:

- Certified, Senior, or Master Technician
- Certified, Senior, or Master Diagnostic Technician

[ELF GR ENGINE FUEL PRESSURE SENSOR GASKET VIDEO OVERVIEW](#)

I. OPERATION FLOWCHART

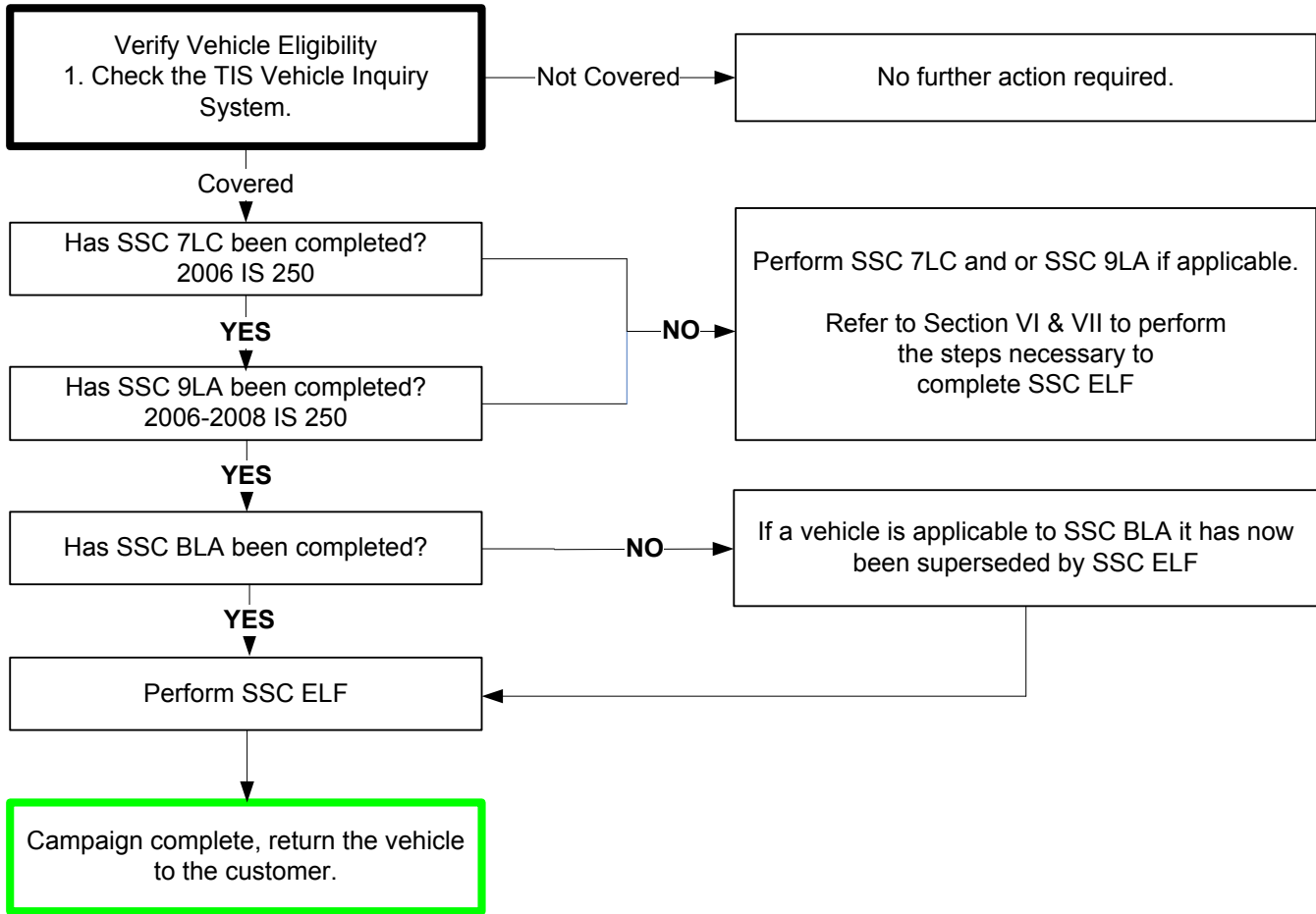

NOTE:

- Check the TIS Vehicle Inquiry System to confirm the VIN is involved in this Safety Recall, and that the campaign has not already been completed prior to dealer shipment or by another dealer.
- **TMS warranty will not reimburse dealers for repairs conducted on vehicles that are not affected or were completed by another dealer.**

II. PREPARATION

A. PARTS

Model	Part Number	Part Description	Quantity
IS 250 & IS 250C	04004-35831	Fuel Pressure Sensor Gasket Kit	1

The kit contains the following parts

90430-12026	Fuel Pressure Sensor Gasket	1
17176-31170	Air Surge Tank to Intake Manifold Gasket	1
17177-31021	Intake Manifold to Cylinder Head Gasket	2
23293-31010	Cold Start Injector Gasket	1
09264-99020	Polishing Brush Pad	1

B. TOOLS

- Standard hand tools
- Techstream
- Blow gun
- Torque wrench
- Air Ratchet

The following special campaign tools where sent to the Dealership free of charge.

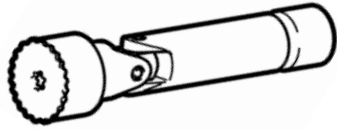

Fuel Delivery Pipe Polishing Tool
(with Spare Velcro)

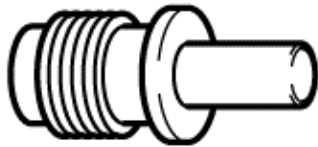

Polishing Guide Tool
(with thread protector)

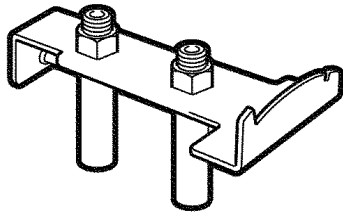

Torque Angle Plate for GR Engines



24 mm Open End Wrench



Torque Wrench Adaptor

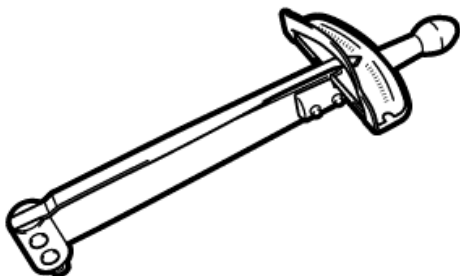

Torque Wrench

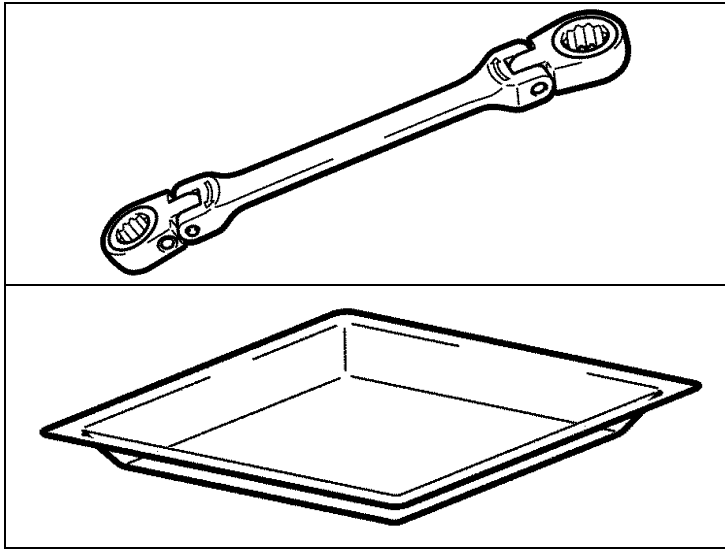

Box End Wrench

Surge Tank Tray

C. EQUIPMENT & MATERIALS

- Brake cleaner
- Protective tape
- Pando39C Adhesive spray

(Note: one can will service approximately 120 vehicles)

An initial quantity of the required Pando 39C (**00289-ELF39**) has been shipped to each dealer. Please contact your DSPM to request additional quantities of Pando 39C. Your DSPM will contact Lexus headquarters who will evaluate your ELF paid warranty claim volume, overall remaining UIO, and availability of Pando 39C. Upon Lexus headquarters approval your dealership will be authorized to submit an order for the approved quantity via the LCMC website.

III. WORK PROCEDURE TABLE OF CONTENTS

Background -----	Section IV
Disassemble The Vehicle -----	Section V
Polish Fuel Delivery Pipe -----	Section VI
Reinstall The Fuel Pressure Sensor -----	Section VII
Reassemble Vehicle -----	Section VIII
Appendix -----	Section IX
Removed Parts -----	Section X

IV. BACKGROUND

In the subject vehicles, the sealing property of the gasket seated in between the pressure sensor and the fuel delivery pipe could become degraded. During vehicle operation, fuel could leak past the gasket. In the presence of an ignition source, this could increase the risk of a vehicle fire.

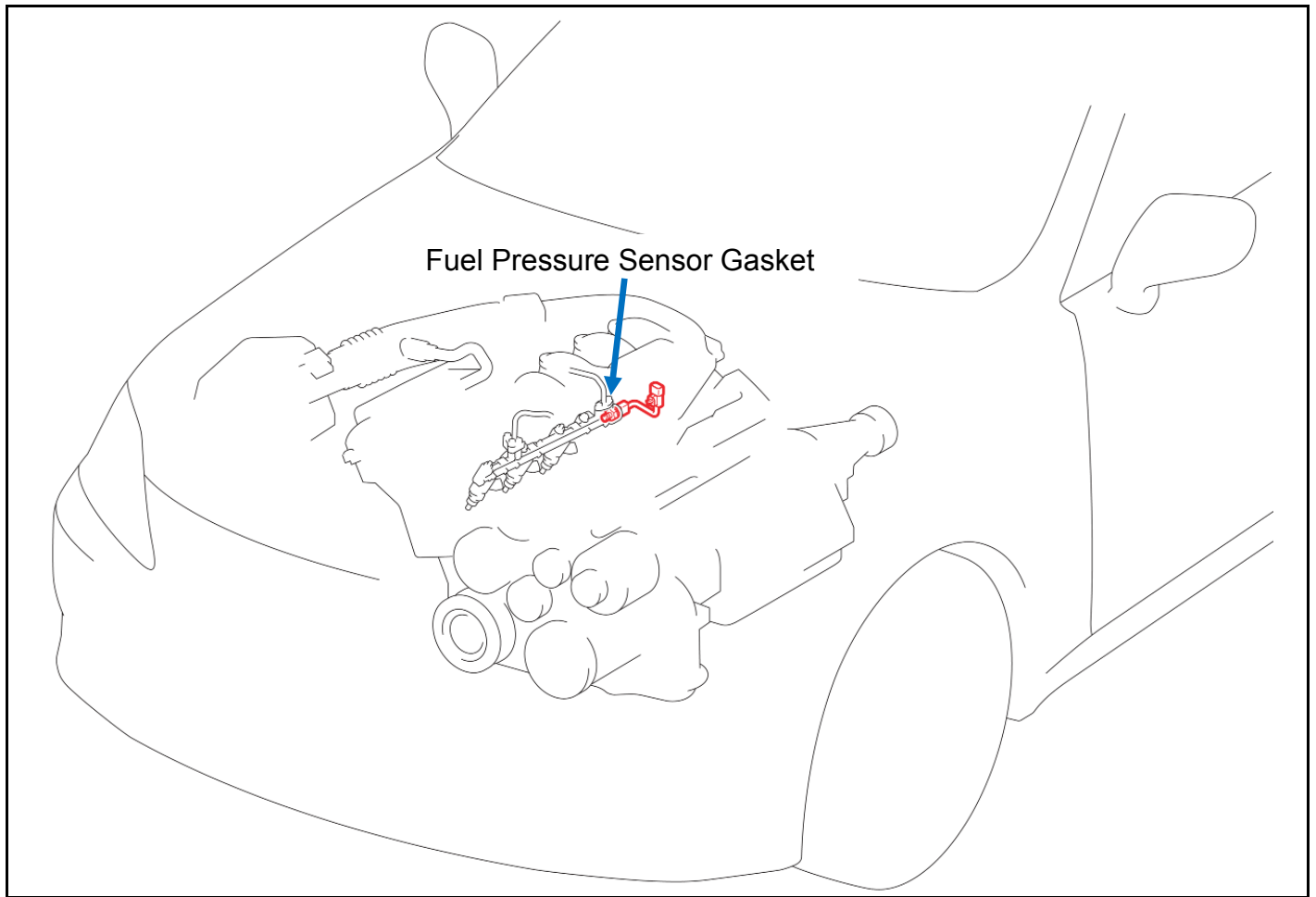

V. DISASSEMBLE THE VEHICLE

A. COMPONENTS

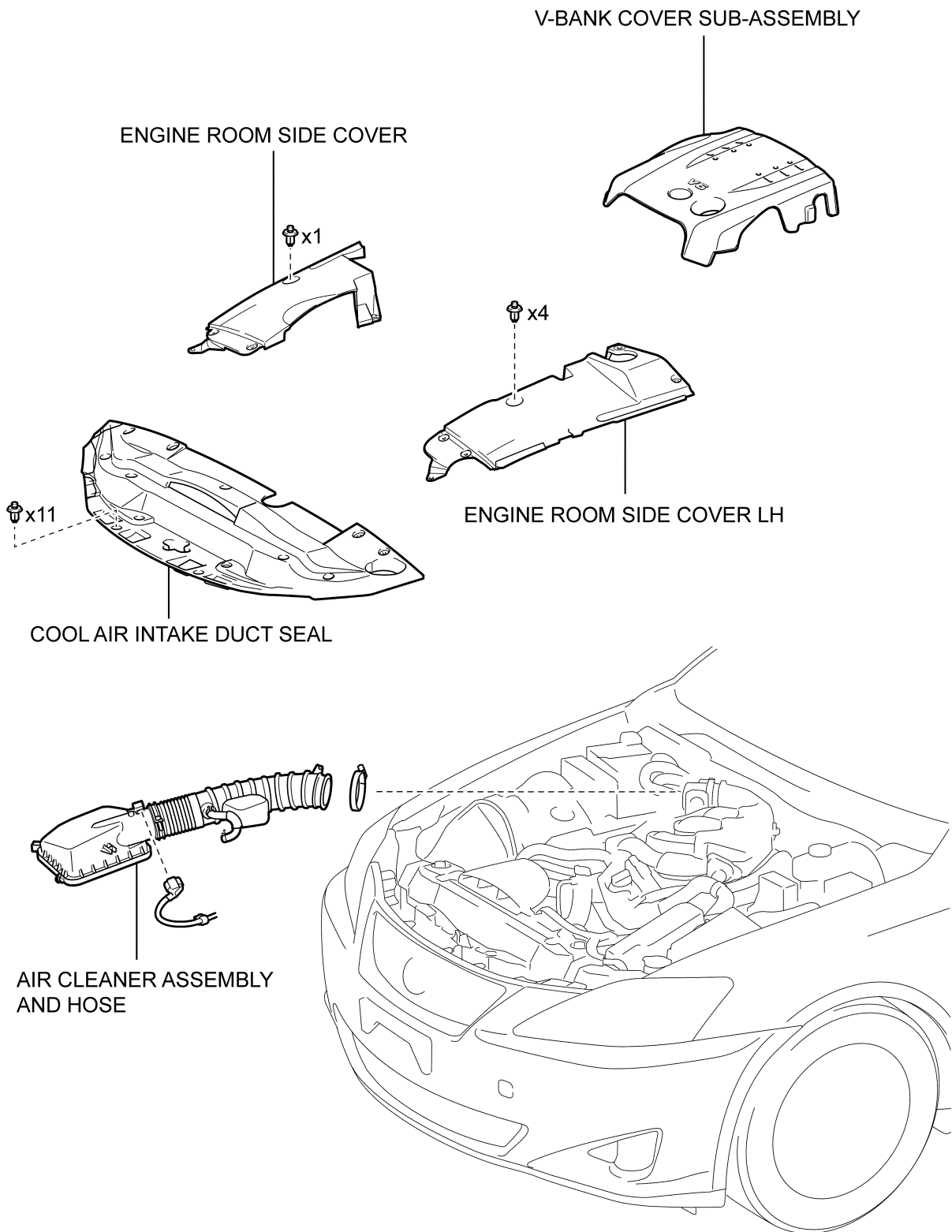

S40018aS

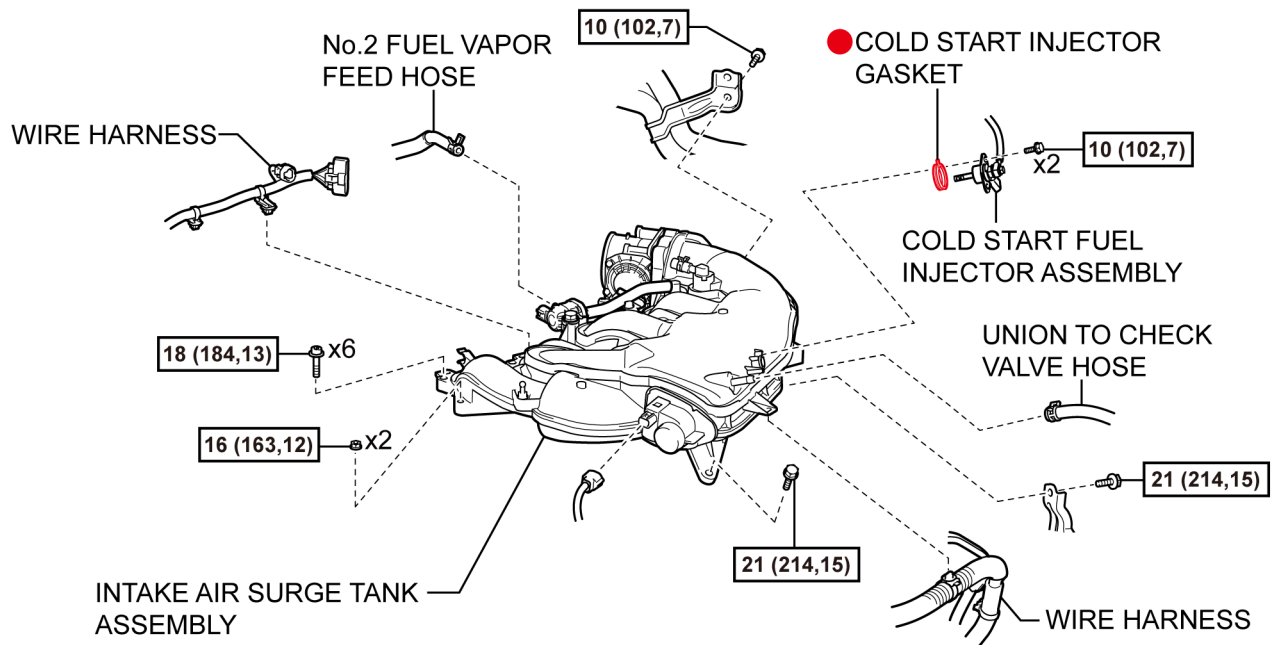

(DO NOT fully remove but move the assembly on a side)

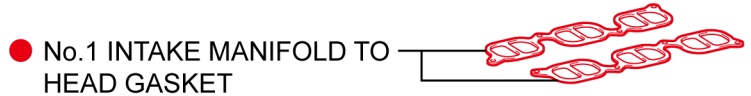
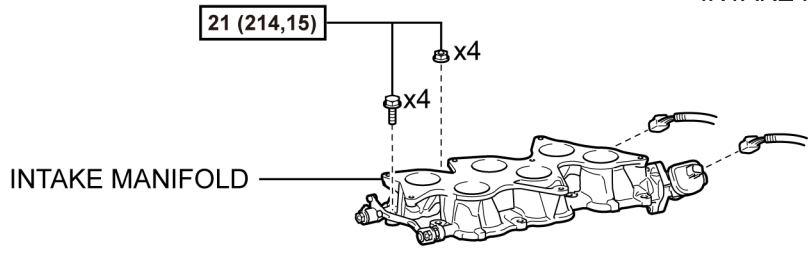

FUEL PRESSURE SENSOR
Tighten as specified in WORK PROCEDURE

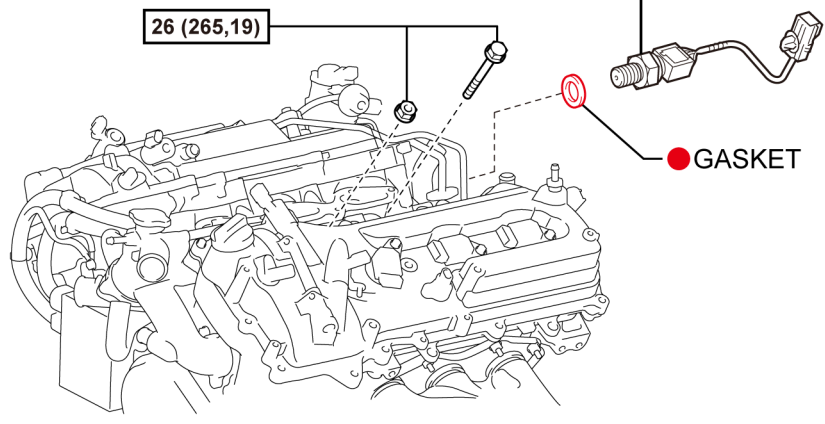

● : Component to be replaced

N*m (kgf*cm, ft.*lbf) : Specified torque

B. CHECK SYSTEM FOR DTC's.



This campaign only covers the replacement of the fuel pressure sensor gasket. No other components in the engine management or fuel system are covered by this campaign.

- a) Using Techstream, perform a health check to confirm if there are any fuel system management related DTCs present in the system (current, history or pending).

NOTES:

- Ensure that the Techstream software is 9.2 or higher.
- On the "connect to vehicle" screen, enter the VIN number to ensure that the vehicle information is uploaded to TIS.
- Record any fuel system management DTCs to aid in any additional discussions needed with the customer.

C. REMOVE THE ENGINE ROOM COVERS

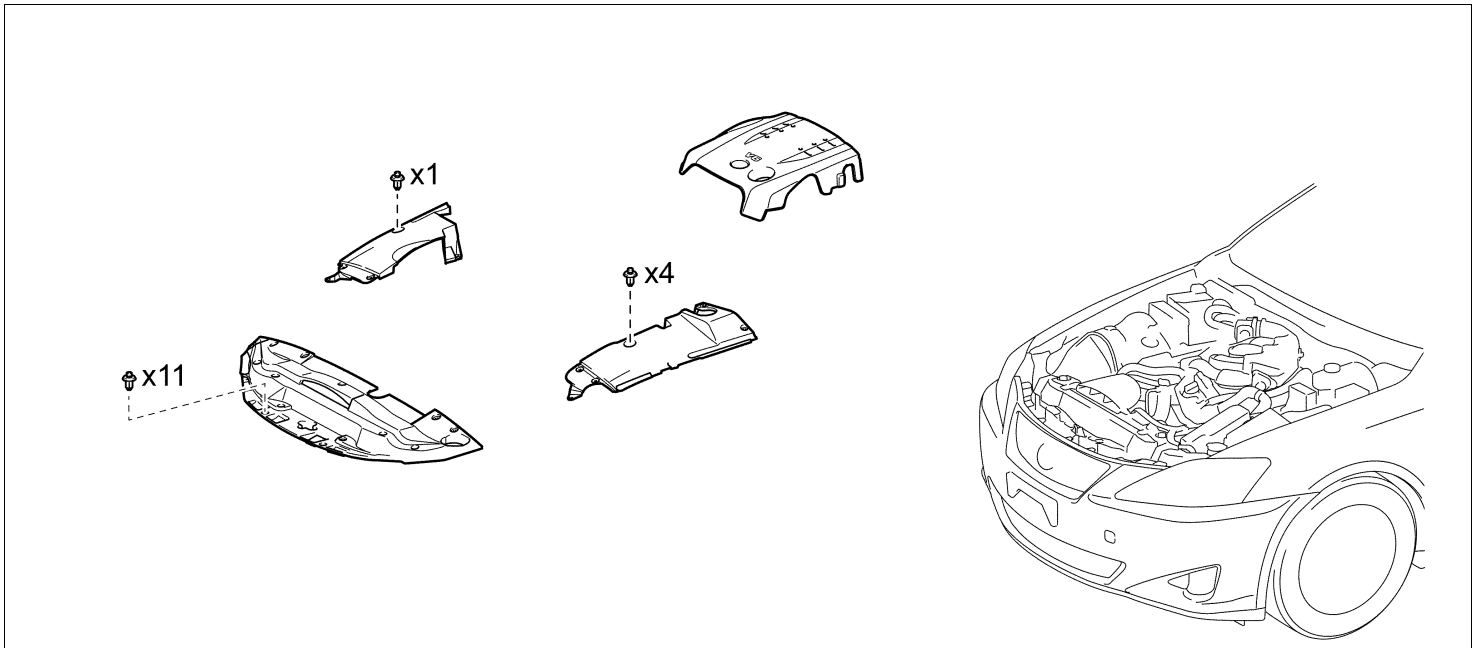

D. DISCHARGE THE FUEL SYSTEM PRESSURE



- **DO NOT** disconnect any part of the fuel system until you have discharged the fuel system pressure.
- Even after discharging the fuel system pressure; place a shop cloth around the fuel pressure sensor as you separate it to reduce the risk of fuel spraying on yourself and in the engine compartment.

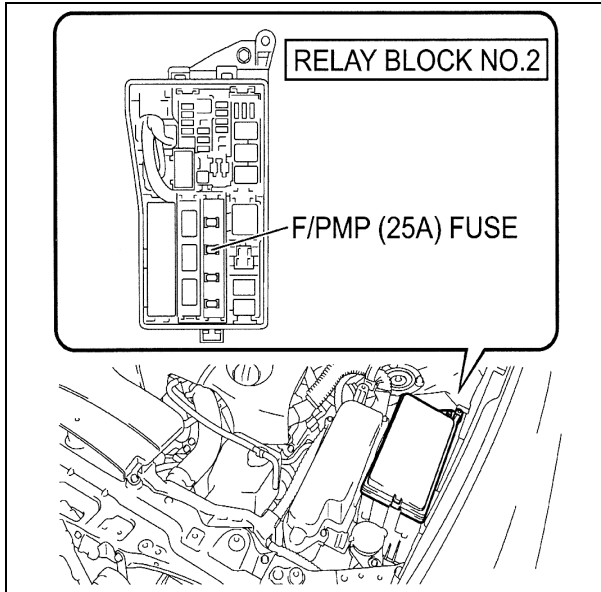

1. DISCHARGE THE FUEL SYSTEM PRESSURE

- Remove the relay block cover.
- Remove the F/PMP fuse.
- Start the engine.
- After the engine has stopped, turn the ignition switch OFF.

NOTE:

DTCs related to fuel pressure, lean fuel mixture, and/or engine stop may be detected.

- Remove the fuel tank cap to discharge the fuel tank pressure.

NOTE:

DO NOT reinstall the fuel tank cap.

2. DISCONNECT THE NEGATIVE BATTERY CABLE

NOTE: For models with a navigation system, wait at least 6 minutes before disconnecting the battery. The system requires approximately 6 minutes to save information and settings after vehicle shut down.

- Reinstall the F/PMP fuse.
- Reinstall the relay block cover.

E. REMOVE THE INTAKE AIR SURGE TANK

1. REMOVE THE AIR CLEANER ASSEMBLY AND HOSE

- a) Disconnect the MAF connector.
- b) Disconnect the ventilation hose.
- c) Disconnect the hose at the throttle body.
- d) Unclip the hose.
- e) Remove the 4 clips and air cleaner cap with the hose.
- f) Remove the air filter.

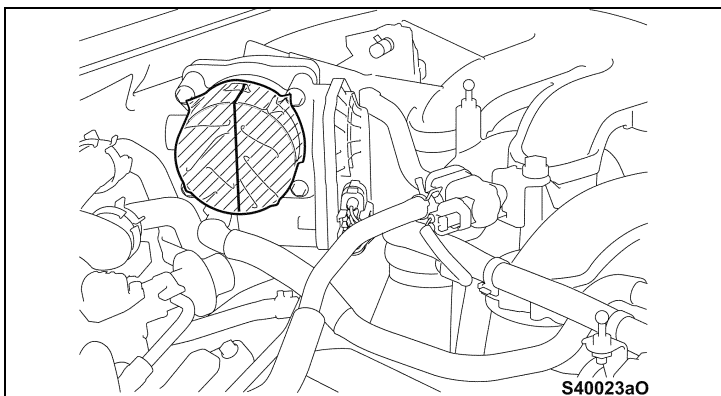
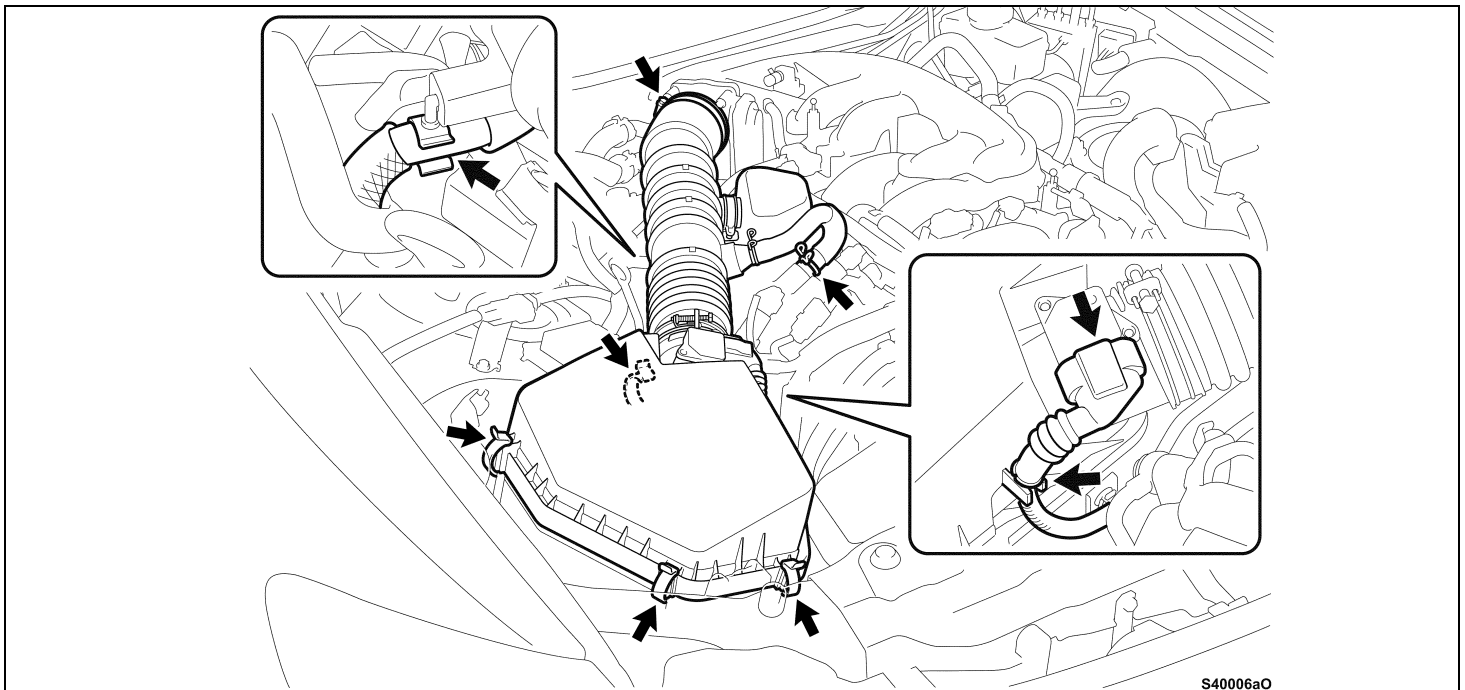

2. REMOVE THE INTAKE AIR SURGE TANK

- a) Place protective tape over the throttle body assembly opening to prevent foreign objects from entering the surge tank.

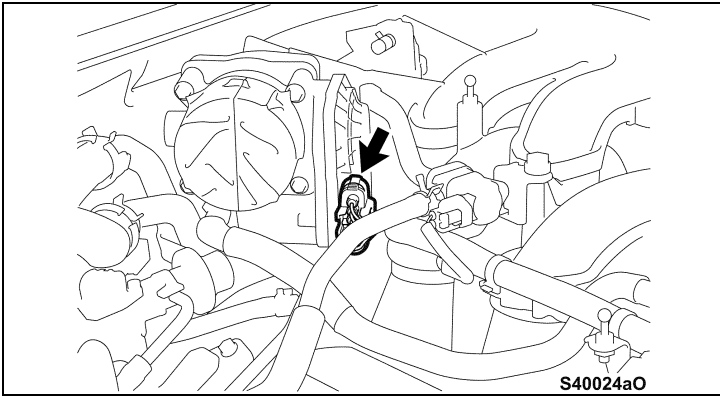

b) Disconnect the throttle body connector.

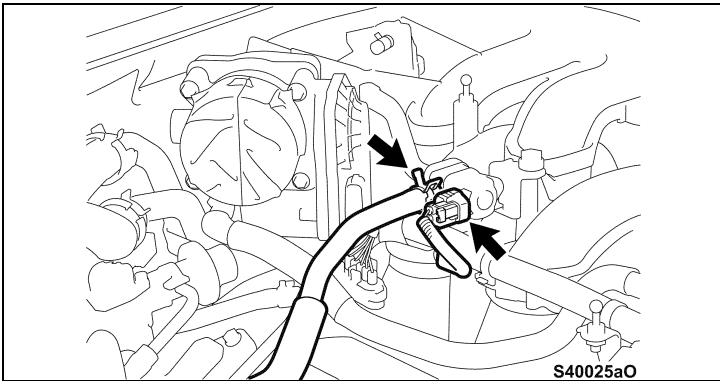

c) Disconnect the No. 2 fuel vapor hose.

d) Disconnect the vacuum switching valve connector.

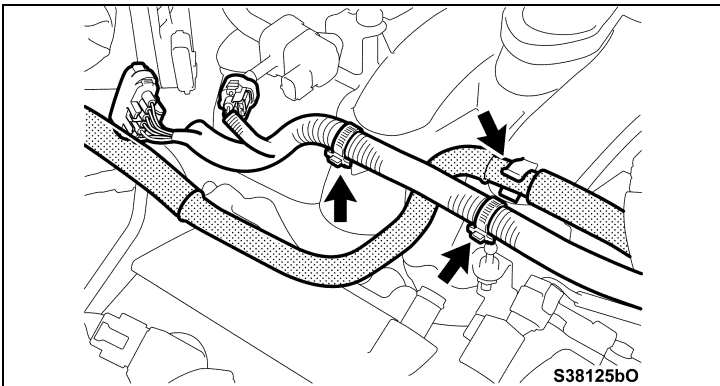

e) Disengage the 2 wire harness clamps and disconnect the No.2 water by-pass hose from the air surge tank.

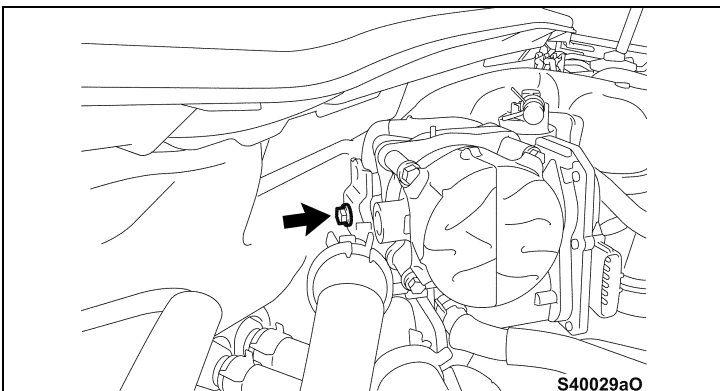

f) Using the supplied box wrench remove the bolt for the water pipe stay.

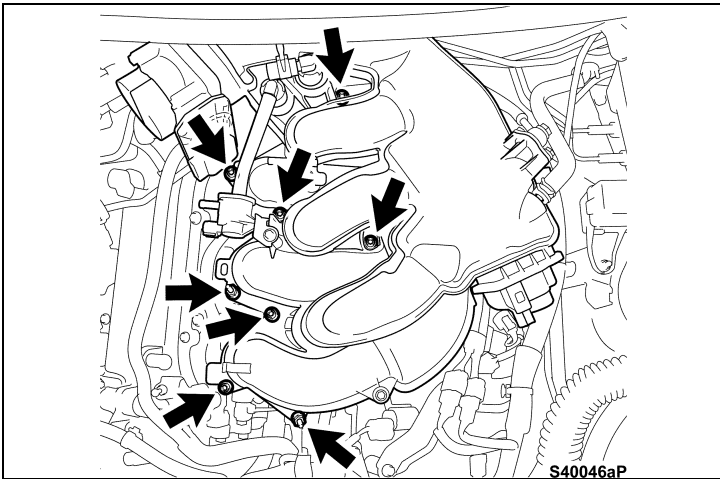

g) Remove the 6 bolts and the 2 nuts for the air surge tank.

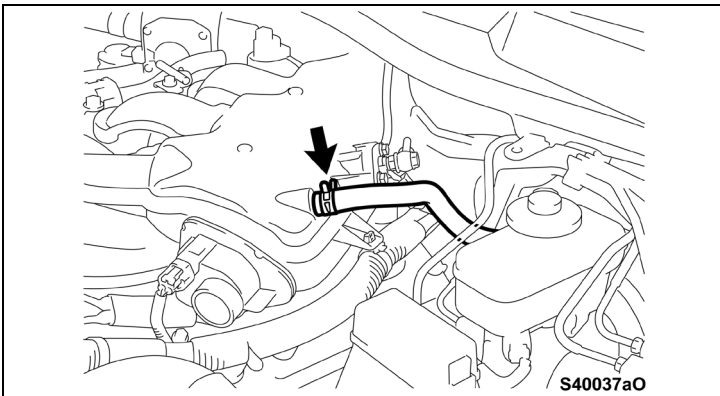

h) Disconnect the union to check valve hose.

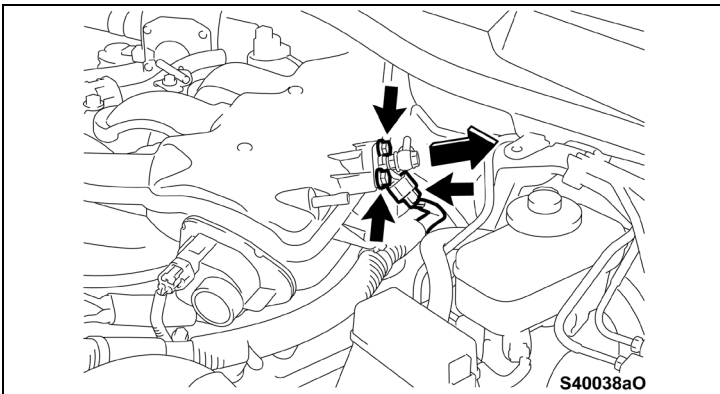

i) Disconnect the cold start injector.

j) Remove the two bolts and remove the cold start injector **with the fuel line attached.**

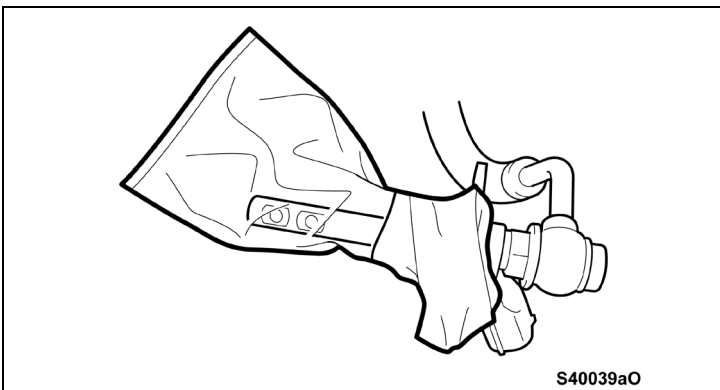

k) Cover the cold start injector to prevent damage.

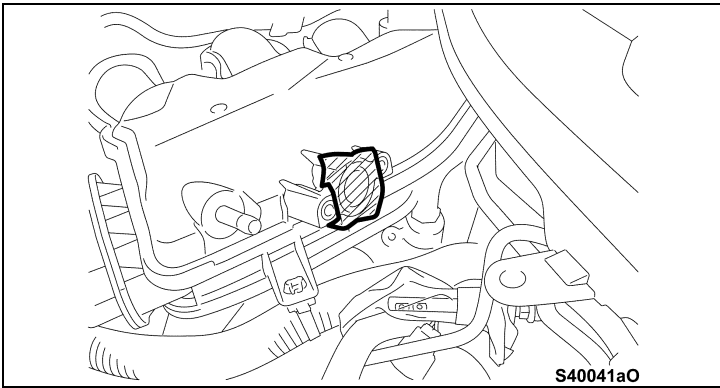

l) Remove and discard the cold start injector gasket.

m) Cover the cold start injector port with tape to prevent foreign objects from entering the surge tank.

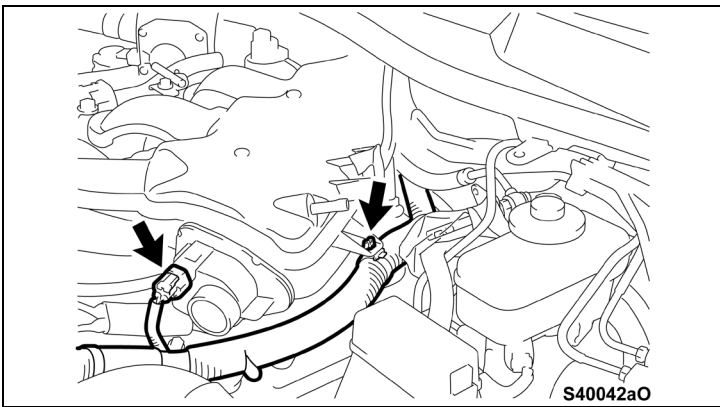

n) Disconnect the connector.

o) Disconnect the wire harness clamp.

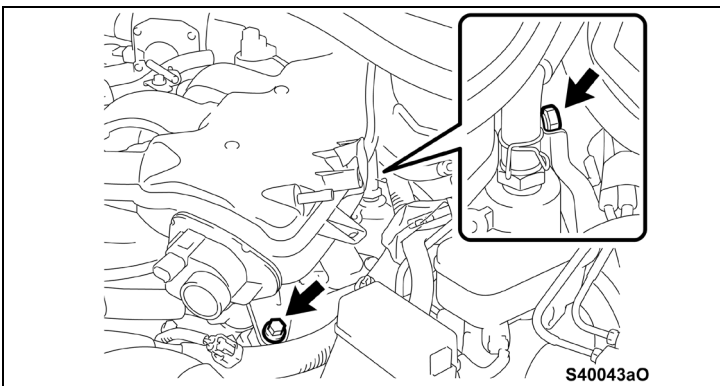

p) Remove the 2 bolts from the side of the air surge tank.

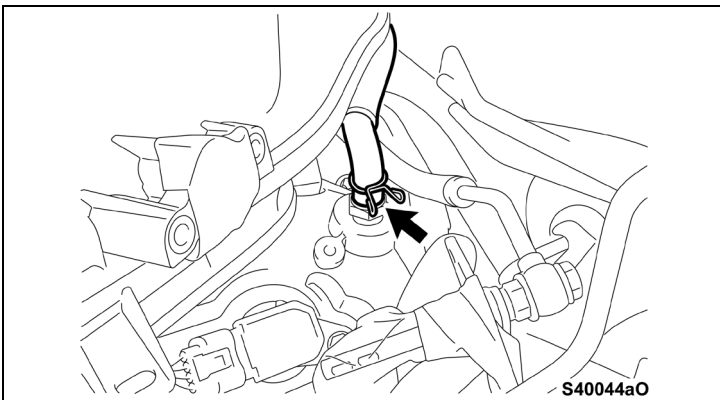

q) Move the surge tank and disconnect the left rear bank ventilation hose.

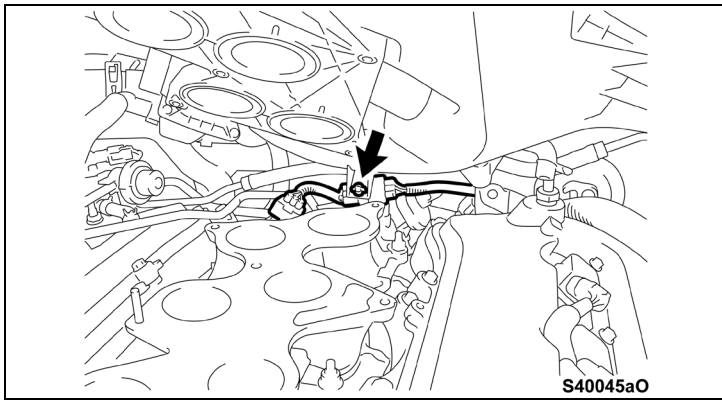

- r) Detach the clamp of the SCV position sensor connector from the surge tank.

s) Cover the supplied surge tank tray with a cloth and place the tray on the right side of the engine compartment.

t) Ensure the air surge tank is unbolted and carefully separate it from the intake manifold and place it on the tray as shown.

NOTE: Ensure that other parts in the engine compartment are not damaged by the air surge tank.

Do not hold or store the air surge tank vertically, engine oil could leak out. In the event that oil leaks from the t-body clean it with a cloth. **DO NOT** use brake clean as it could damage the t-body.

Ensure that the water hose is not tensioned.

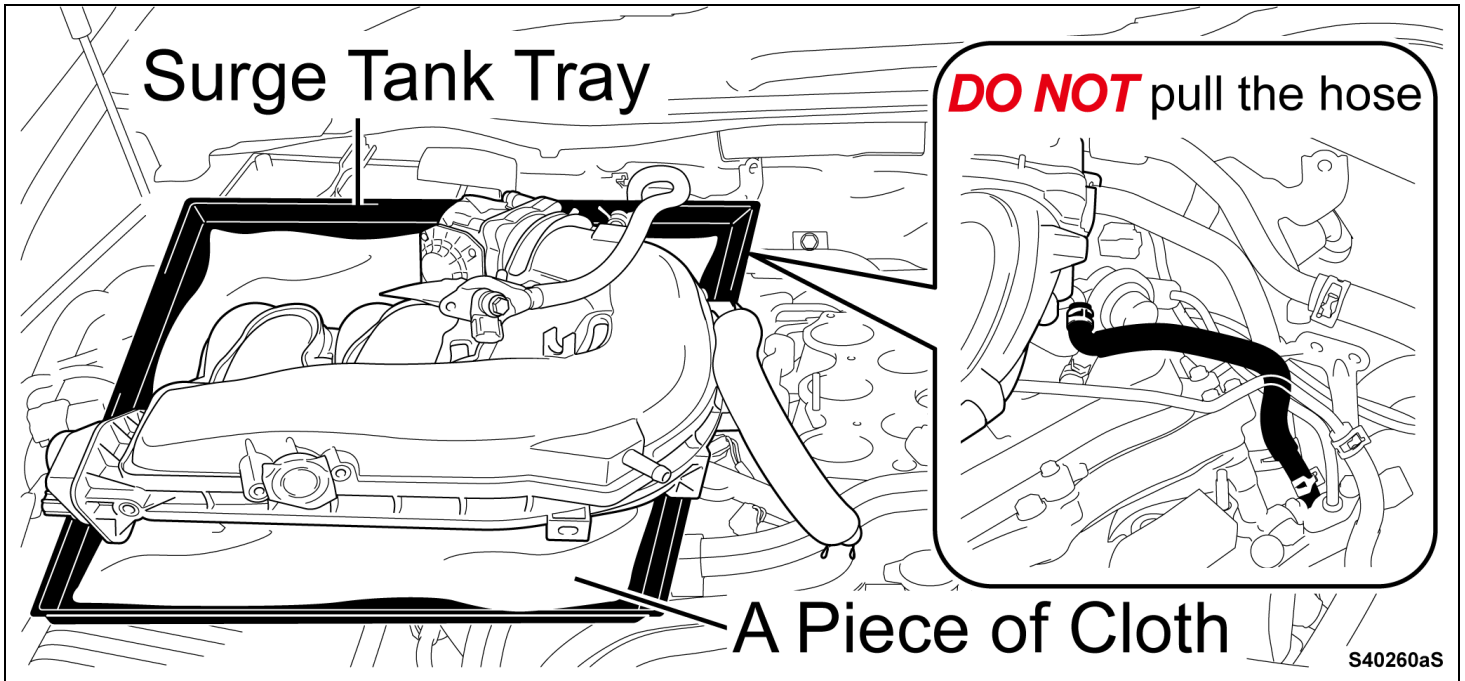



u) Remove and discard the air surge tank gasket.

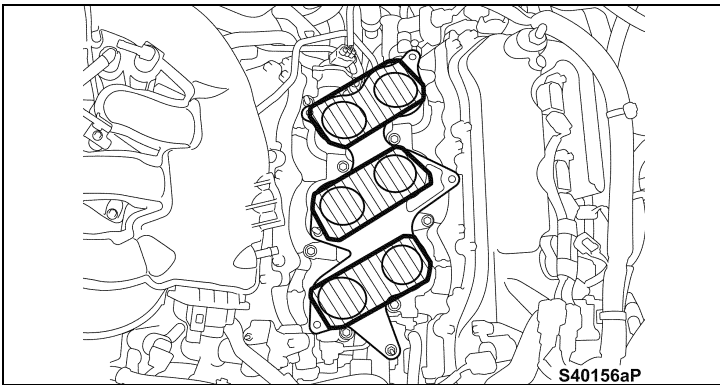

v) Place protective tape over the intake manifold ports to prevent foreign objects from entering.

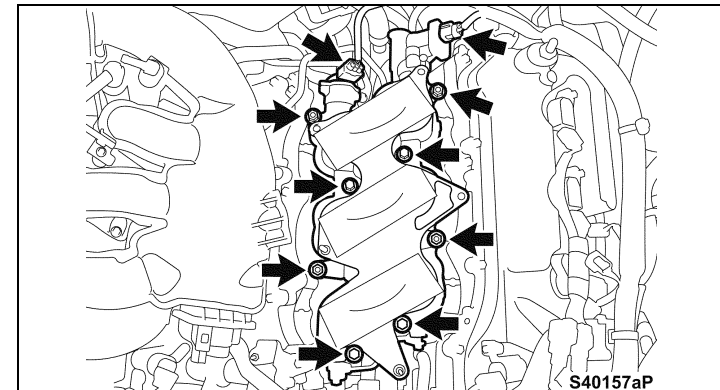

3. REMOVE THE INTAKE MANIFOLD

a) Disconnect the 2 connectors.

b) Remove the 4 bolts and 4 nuts and remove the intake manifold.

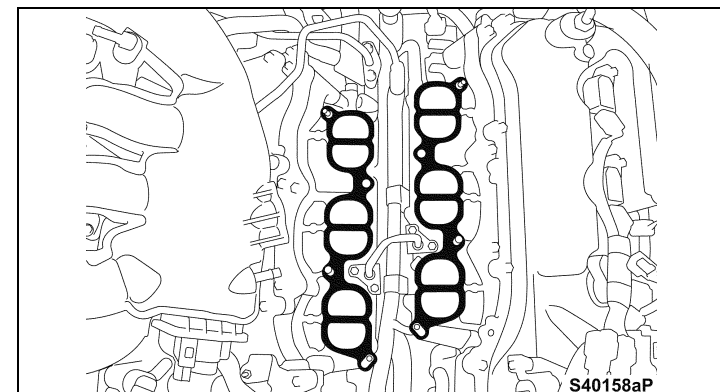

c) Remove and discard the intake manifold gaskets.

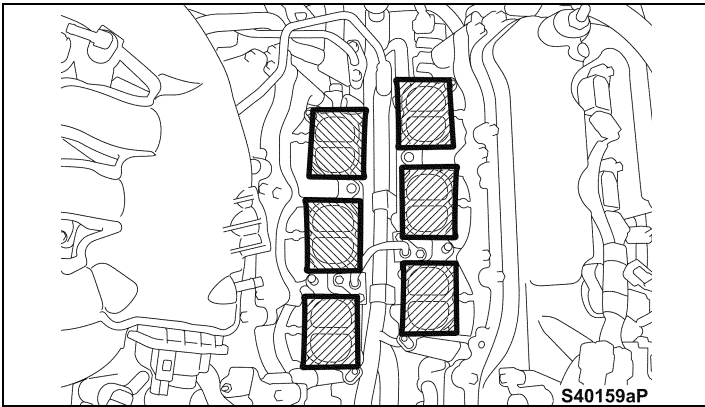

- d) Cover the openings with tape to prevent foreign objects from entering the intake ports.

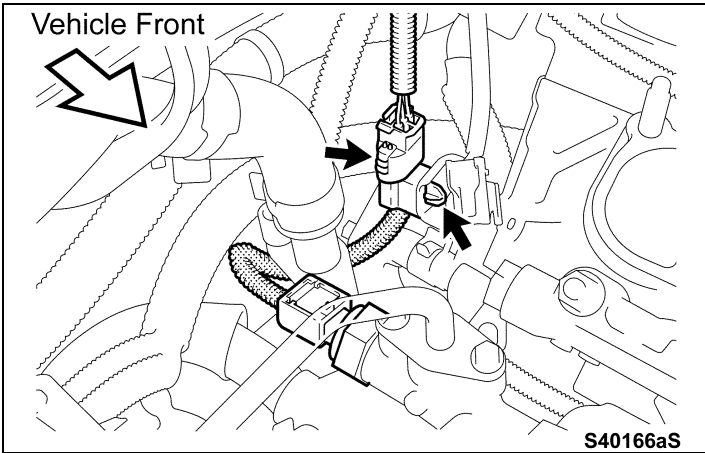

4. REMOVE THE FUEL PRESSURE SENSOR

- a) Disconnect the fuel pressure sensor connector and detach the clamp.

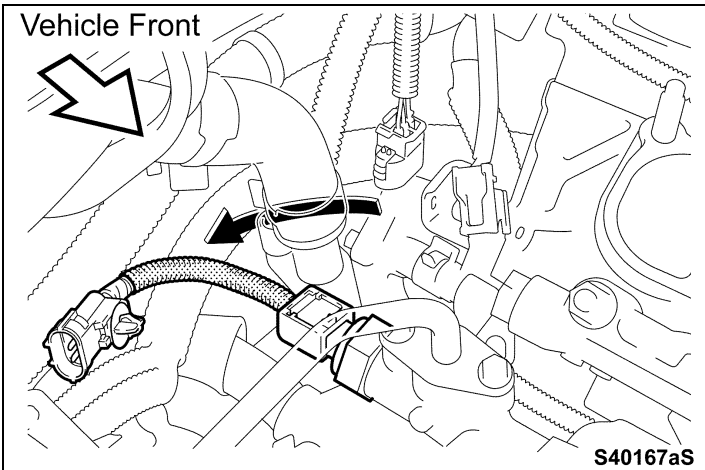

- b) Route the sensor harness from behind the heater hose.

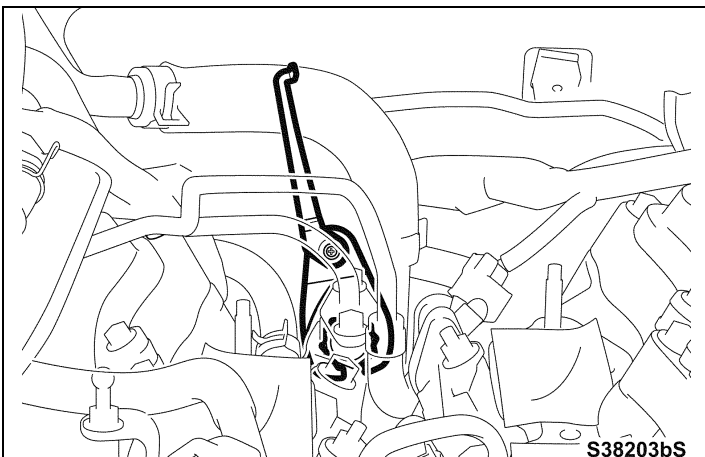

- c) Place the supplied 24 mm wrench onto the sensor.

NOTE: Place a cloth under the sensor to absorb any fuel.
DO NOT apply any force to the needle on the wrench.

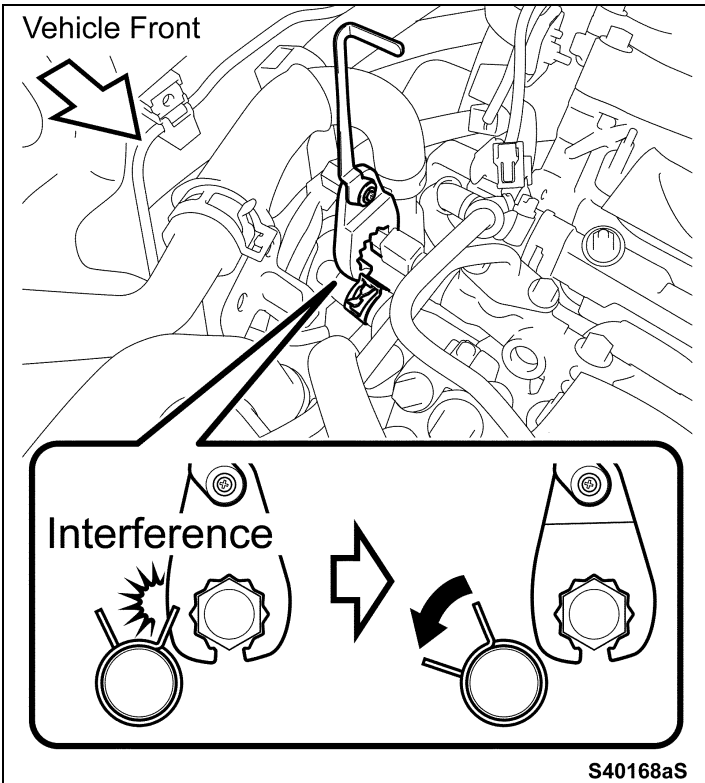

NOTE: It may be necessary to rotate the clamp for the heater hose to allow the wrench to fully seat on the sensor.

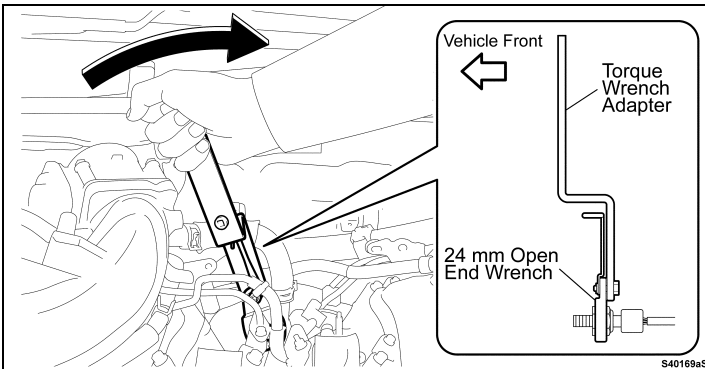

- d) Attach the supplied torque wrench adaptor to the 24 mm wrench as shown and loosen the sensor.

NOTE: The needle on the wrench is not used for sensor removal.

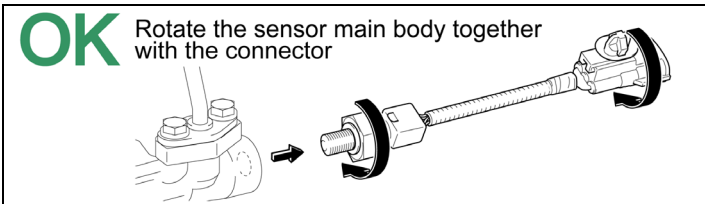

- e) Remove the tool from the sensor and remove the sensor by hand.

NOTE: Rotate the sensor and the connector together to avoid twisting the harness.

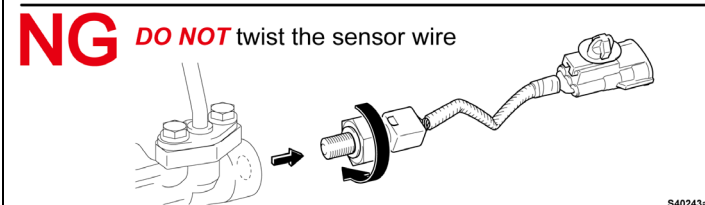

- f) Remove and discard the sensor gasket.

STOP The old pressure sensor will be reused.
DO NOT drop the sensor
 If it is dropped it must be replaced

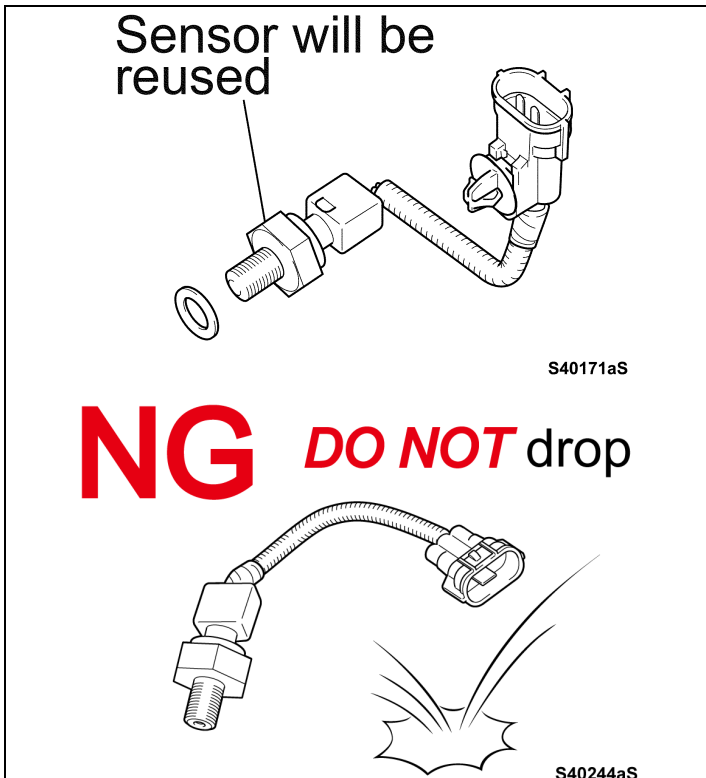

VI. POLISH THE FUEL DELIVERY PIPE

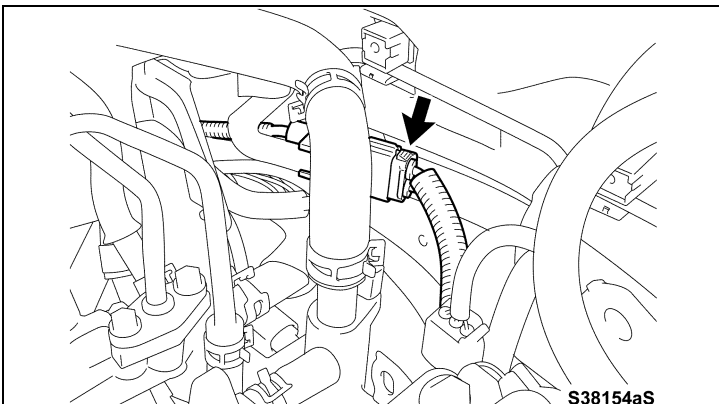

1. DISCONNECT CONNECTOR

- a) Disconnect the connector for the water by-pass glow plug (if equipped).

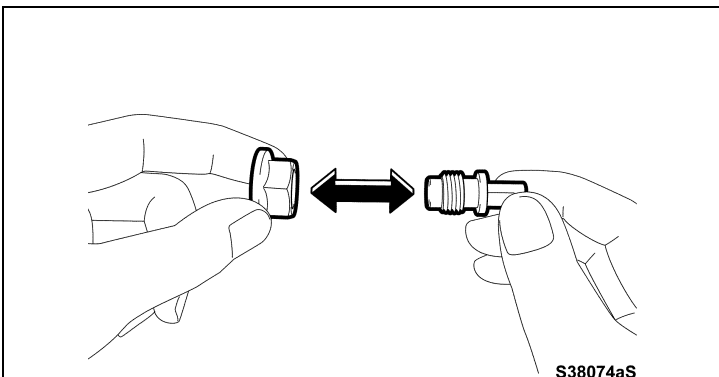

2. INSTALL GUIDE

- a) Remove the supplied guide from the thread protector.
- b) Inspect and clean the threads of the guide.

NOTE: DO NOT dispose of the guide protector it is needed to store the guide.
 Replace the guide if the threads are damaged.

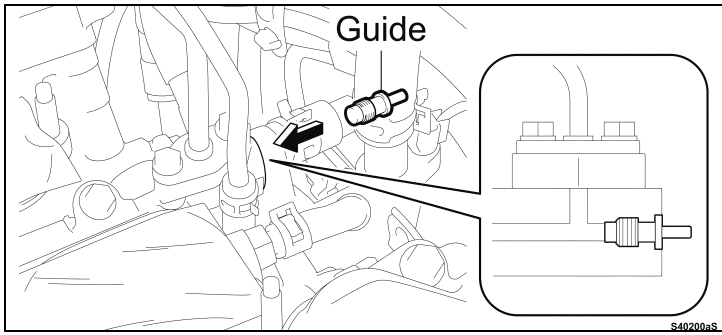

c) Install the guide into the end of the fuel delivery pipe finger tight.

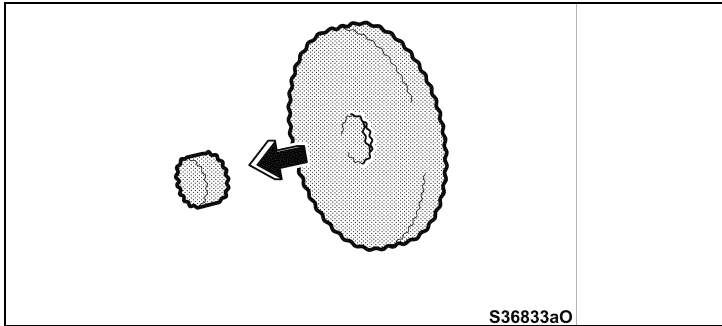

d) Inspect the polishing pad that is contained in the parts kit. Ensure that the center piece of the new pad is removed.

NOTE: DO NOT drop the center piece in the engine compartment.

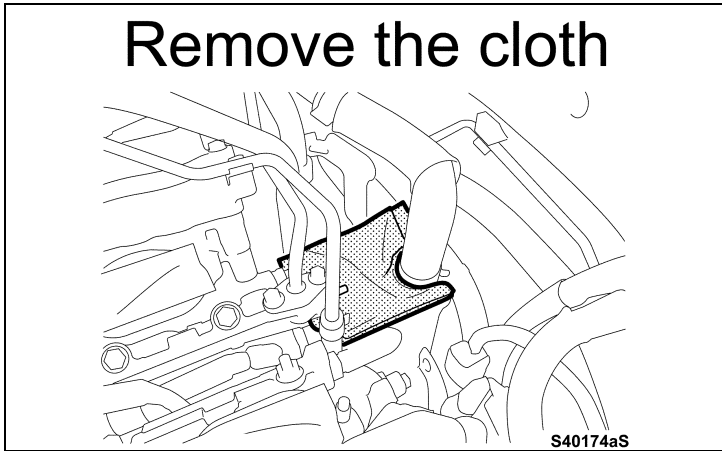

e) Remove the cloth at the end of the fuel rail.

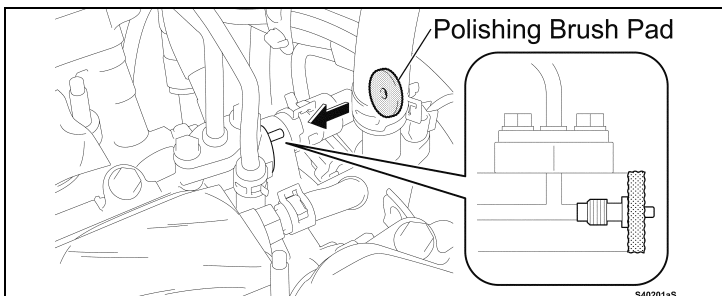

f) Place the NEW polishing pad onto the guide at the end of the fuel delivery pipe.

NOTE: Always use a new polishing pad each time. Either side of the pad can be used.

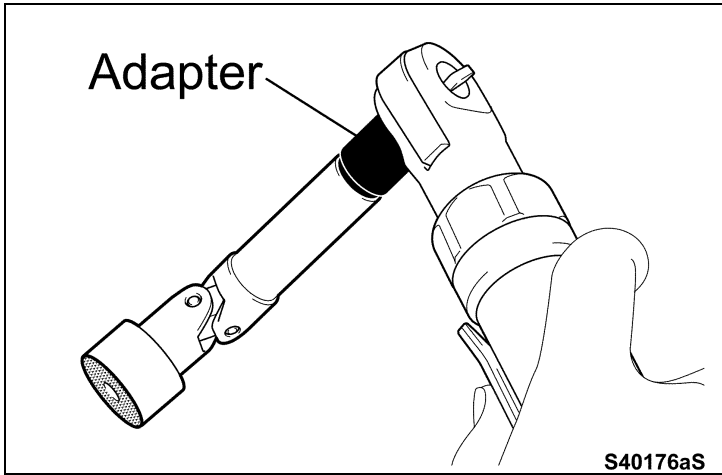

g) Check that the air ratchet will rotate clockwise.

NOTE: Operating the air ratchet in the counter clockwise direction could cause the guide to come out of the delivery pipe.

h) Attach the supplied fuel pipe polishing tool to the air ratchet.

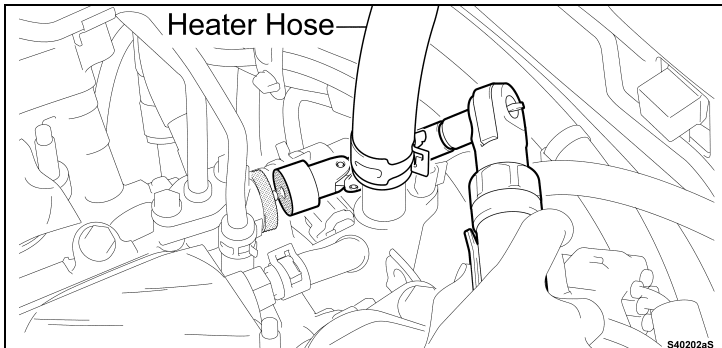

i) Insert the polishing tool behind the heater hose and engage it onto the guide.

NOTE: Check that the pad is in the correct position.

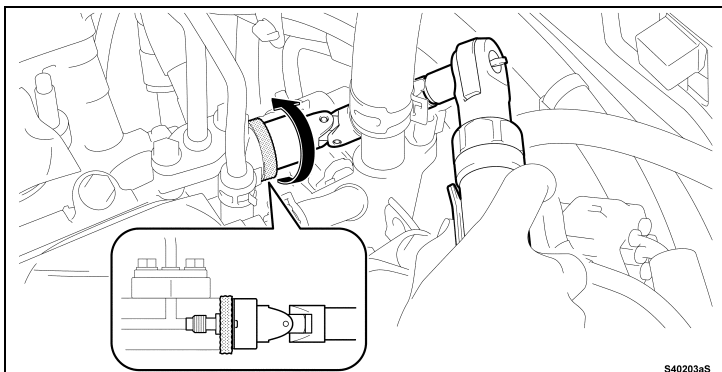

j) Gently push the tool and pad against the end of the delivery pipe.

k) Polish the end of the delivery pipe for 10 seconds.

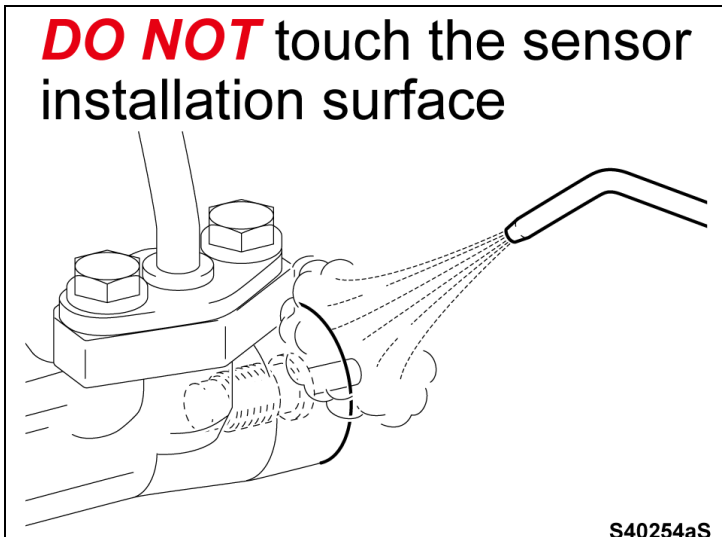

l) Remove the polishing tool and pad from the pipe.

m) Clean the end of the pipe with compressed air.

NOTE: Do not touch the end of the pipe after cleaning.

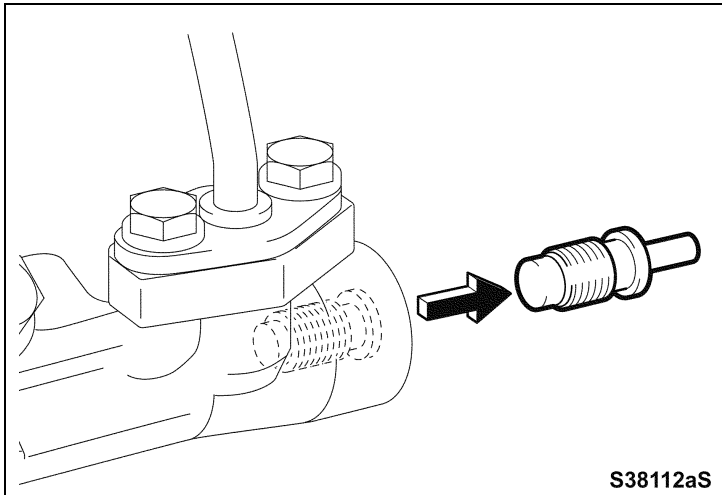

n) Remove the guide from the end of the pipe.

NOTE: The guide may need to be removed with pliers. Be careful not to damage the sensor sealing surface on the end of the pipe.

Return the guide into the protector when it is stored

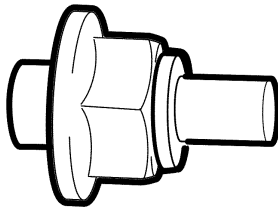

S40183aS

o) Reinstall the guide into the protector to protect the threads.

Reconnect the connector

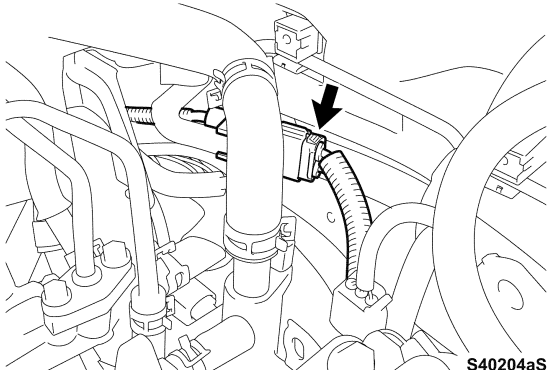

p) Reconnect the connector for the water by-pass glow plug (if equipped).

VII. REINSTALL THE FUEL PRESSURE SENSOR

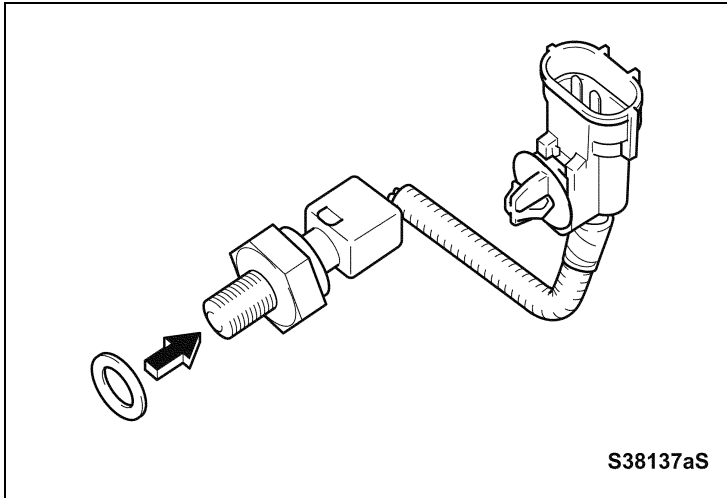

1. REINSTALL SENSOR

- Check the sensor for any damage, and that the threads and sealing surface are clean.
- Check that the **NEW** sensor gasket for damage and that it is clean.
- Install the **NEW** gasket onto the sensor.

Caution:

When reinstalling the fuel pressure sensor to the fuel delivery pipe, follow the specified procedure.

Failure to observe the instructions may cause looseness or deformation of the sensor and could result in abnormal sensor outputs.



The Pando 39C is the only approved product to be used for this campaign.

Do not use any other chemical on the fuel sensor threads.

To order Pando 39C see **Section II Step C**.

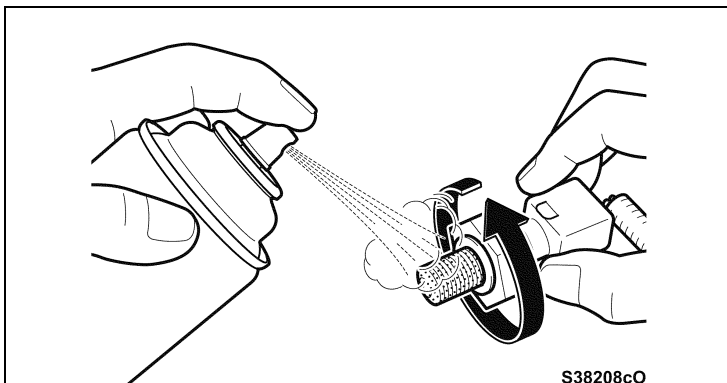

- Spray Pando 39C onto the threaded portion of the sensor.



DO NOT spray the Pando 39C into the connector.

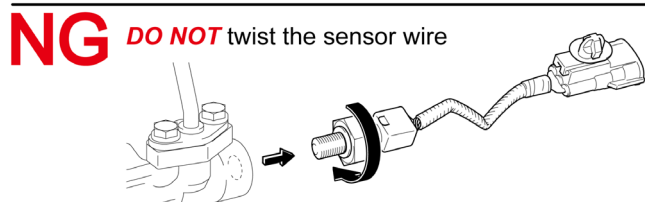
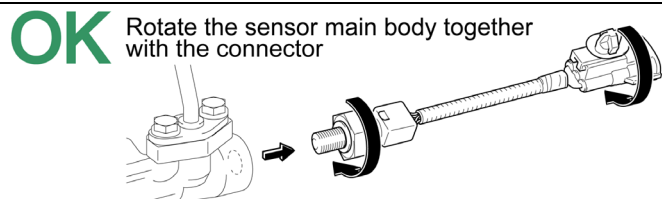

- Reinstall the sensor into the end of the pipe.

NOTE: Rotate the sensor and the connector together to avoid twisting the harness.

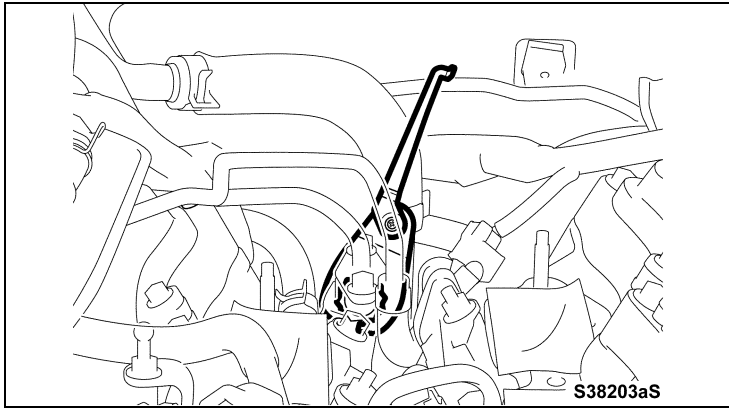

f) Place the 24 mm wrench onto the sensor.

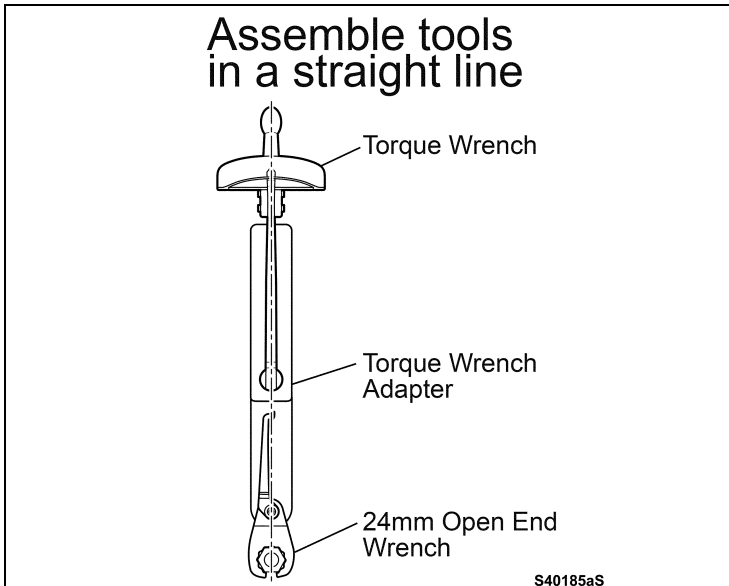

g) Assemble the 24 mm wrench, torque adapter and the supplied torque wrench as shown.

STOP

Only use the torque wrench that was supplied for this campaign.

Ensure that three pieces are assembled in a straight line.

The needle on 24 mm wrench is not used on this initial tightening step.

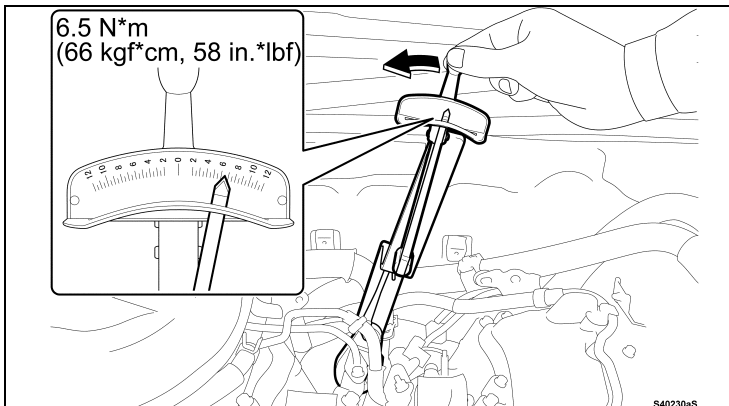

h) Tighten the sensor as shown until the specified torque reading is obtained.

Torque: 6.5 Nm (66 kpf-cm, 58 in-lbs)

NOTE: If the torque specification has been exceeded, replace the sensor gasket with a NEW one and repeat Steps 1c to 1h.

i) Remove the tool from the sensor.

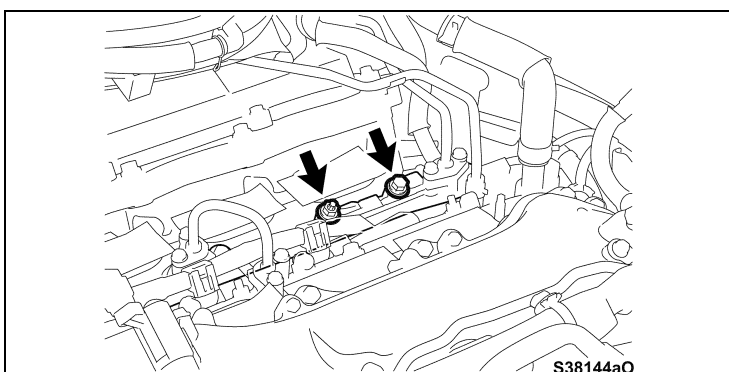

2. SENSOR TORQUE ANGLE

a) Remove the nut and bolt shown from the right fuel delivery pipe.

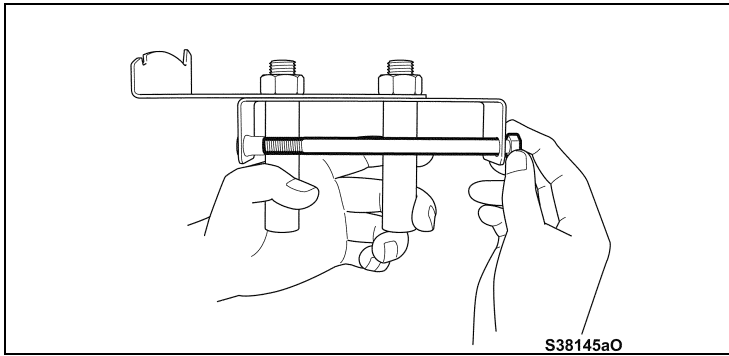

b) Remove the bolt from the supplied GR torque angle plate.

c) Place the GR torque angle plate onto the right delivery pipe.

d) Install the bolt into the location shown and hand tighten.

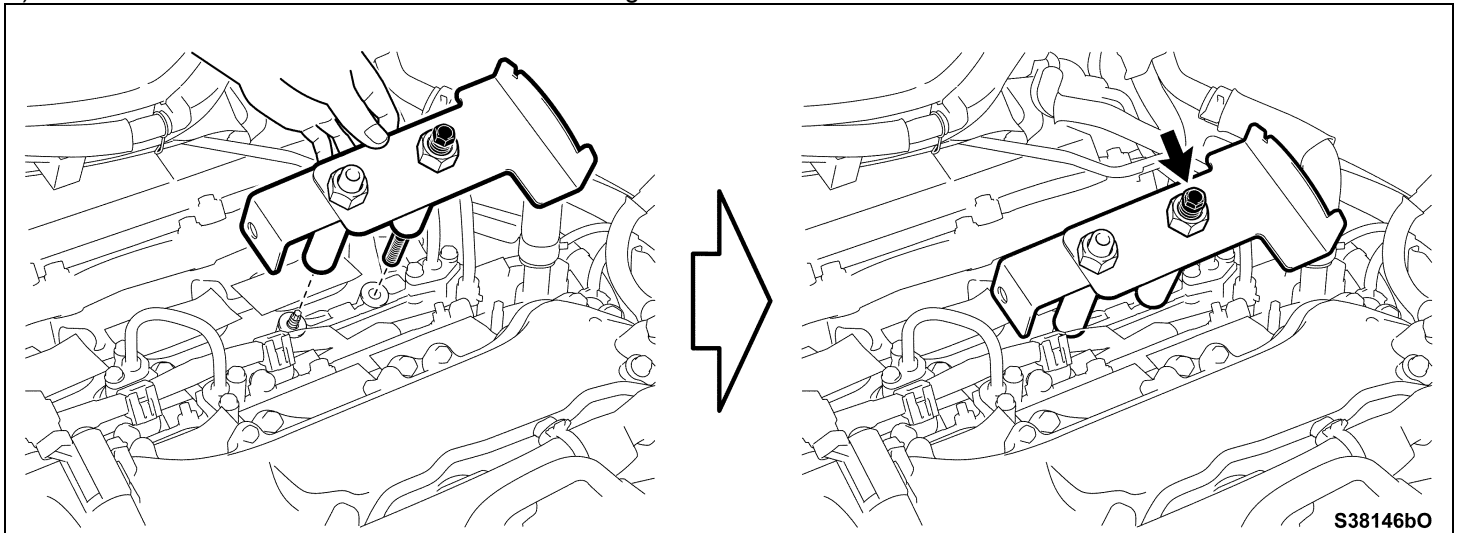

DO NOT skip the torque angle procedure it is the critical step in this repair.

When performing the torque angle procedure be aware of the following:



DO NOT rotate the sensor until ready.

DO NOT rotate the sensor past the indicated notch on the torque angle plate.

If any of the above cautions are violated a NEW fuel pressure sensor gasket will need to be installed and restart the torquing procedure again at step 1c.

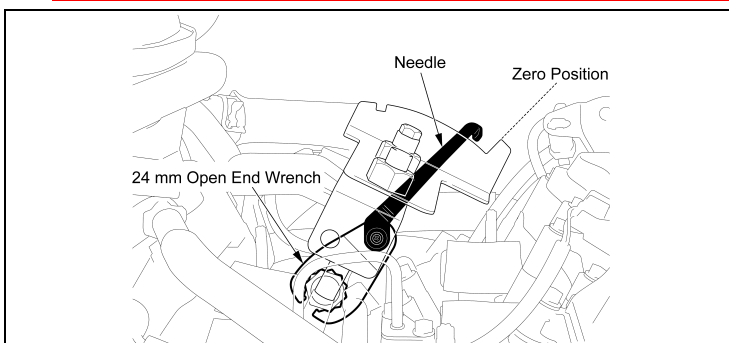

e) Place the 24 mm wrench onto the sensor with the needle as close as possible to the zero position of the torque plate.

NOTE: Do not rotate the sensor while placing the wrench on the sensor. If the sensor is unintentionally rotated during steps 2e through 2g replace the sensor gasket with a new one and start again from step 1c.

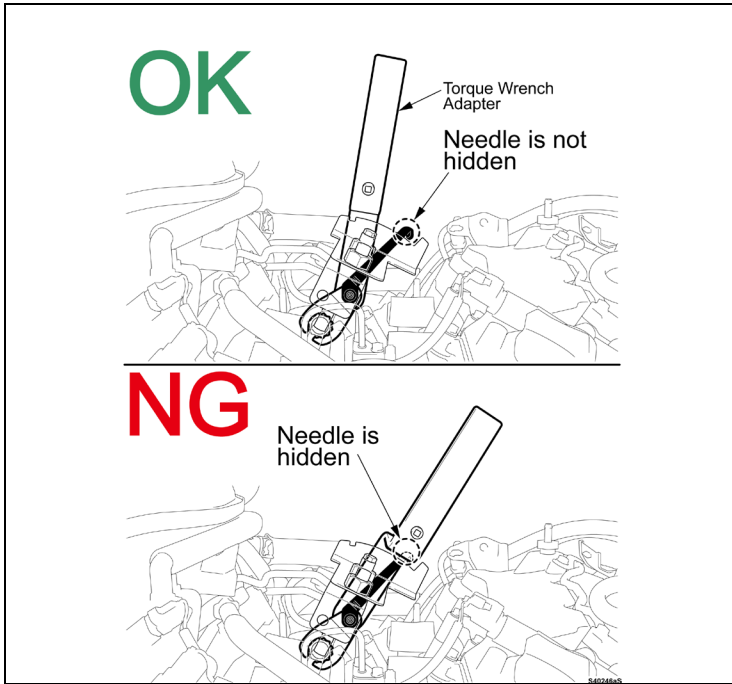

f) Attach the torque wrench adapter to the 24 mm wrench.

NOTE: Make sure that the torque adaptor does not hide the needle on the 24 mm wrench.

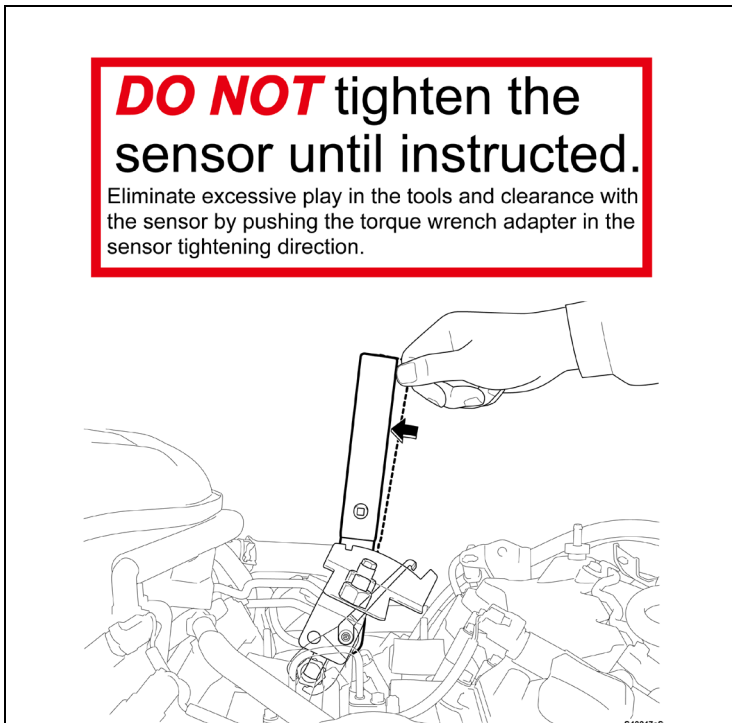

g) Lightly push and hold the torque adapter as shown to eliminate any play but do not rotate the sensor.

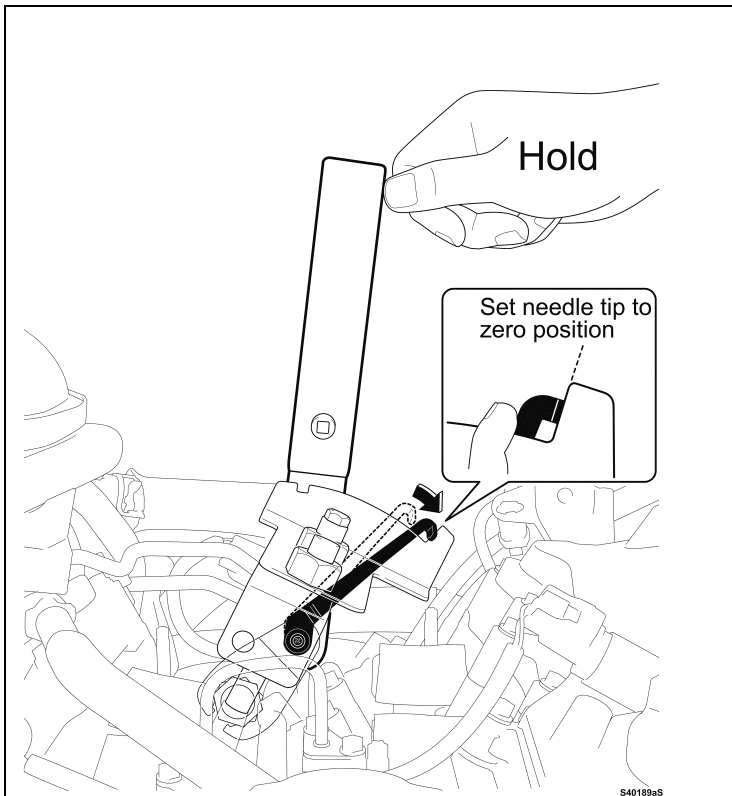

- h) While holding the torque adaptor gently move the needle on the 24 mm wrench to the zero position on the plate.

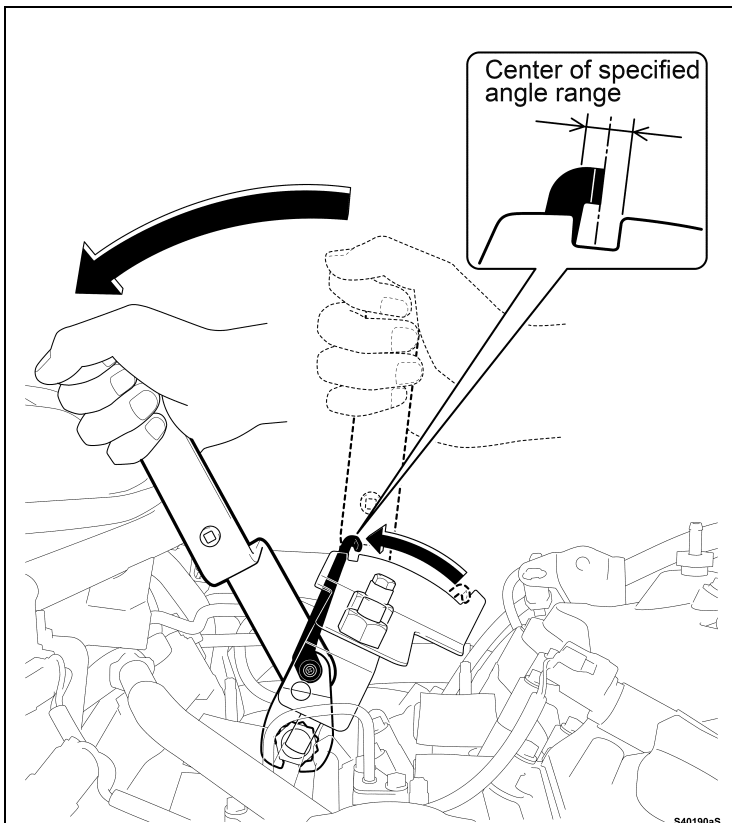

- i) Tighten the sensor until the needle tip aligns with the center of the cut out in the plate as shown.

NOTE: A second technician may be required to watch the needle position as it moves across the torque angle gage.

If the sensor is tightened beyond the specified range, replace the sensor gasket with a new one and start again on Step 1c.

- j) Remove the tools from the sensor.

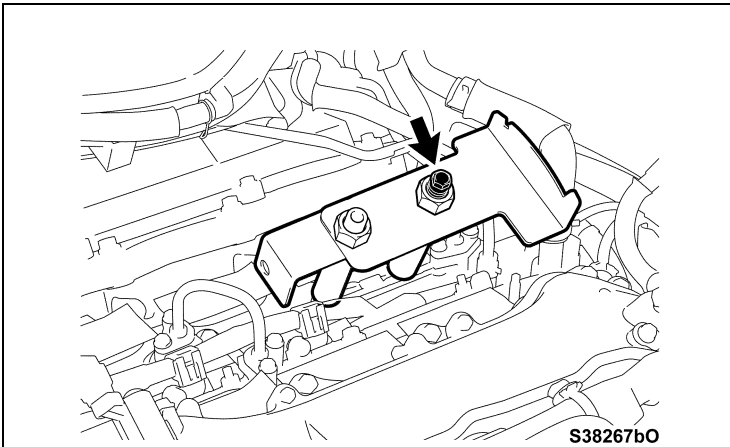

k) Remove the bolt shown and remove the plate.

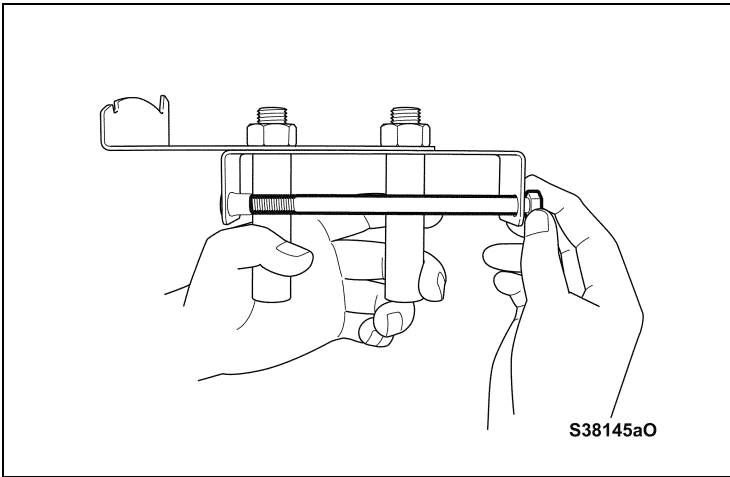

l) Return the bolt to its storage location on the plate.

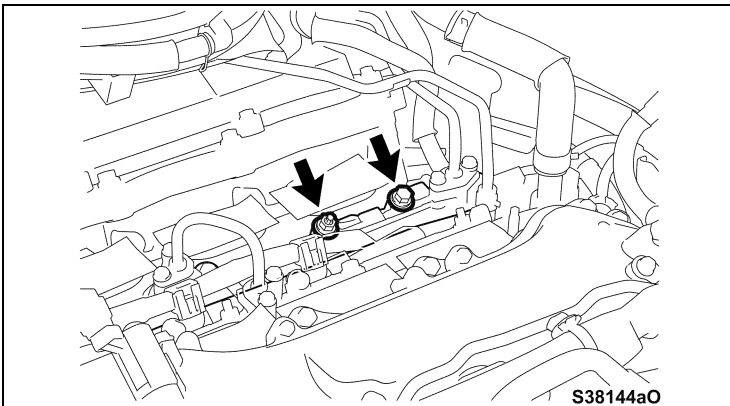

m) Reinstall the bolt and nut for the right fuel delivery pipe.

Torque: 26 Nm (265 kpf-cm, 19 ft-lbs)

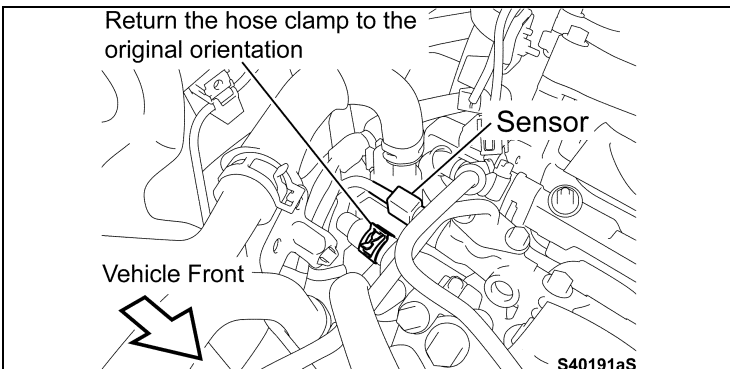

n) Return the clamp for the heater hose to its original position if necessary.

OK

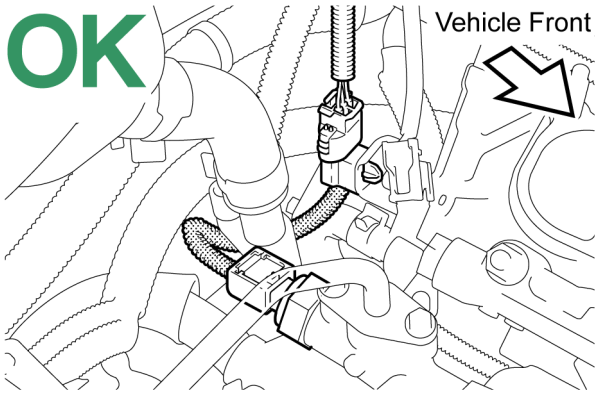

NG

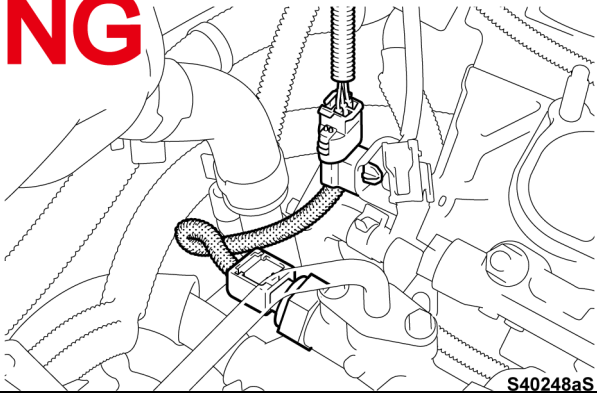

S40248aS

3. RECONNECT THE FUEL PRESSURE SENSOR

- Route the sensor harness behind the heater hose as shown.
- Reconnect the connector and reengage the clamp.

NOTE: Ensure that the harness is not twisted or stressed.

VIII. REASSEMBLE THE VEHICLE

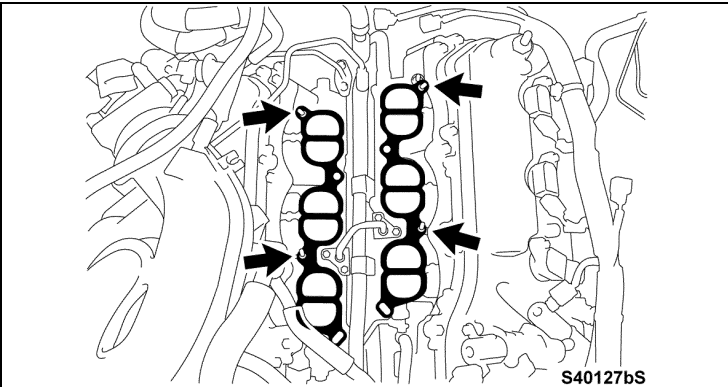

S40127bS

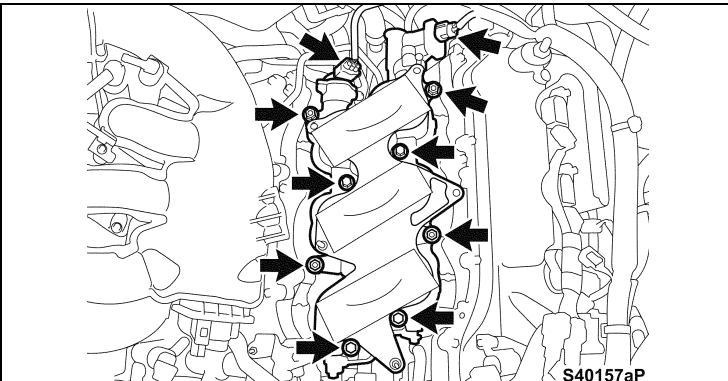

S40157aP

1. REINSTALL THE INTAKE MANIFOLD

- Remove the protective tape from the cylinder head.
- Check the torque of the 4 studs.
Torque: 10 Nm (102 kpf-cm, 7 ft-lbs)
- Clean the gasket surface of the cylinder head.
- Install 2 NEW intake manifold gaskets onto the cylinder heads.
- Reinstall the intake manifold.
- Reinstall the 4 bolts and the 4 nuts.
Torque: 21 Nm (214 kpf-cm, 15 ft-lbs)

NOTE: Uniformly tighten the bolts and nuts in several steps.

- Reconnect the 2 connectors.

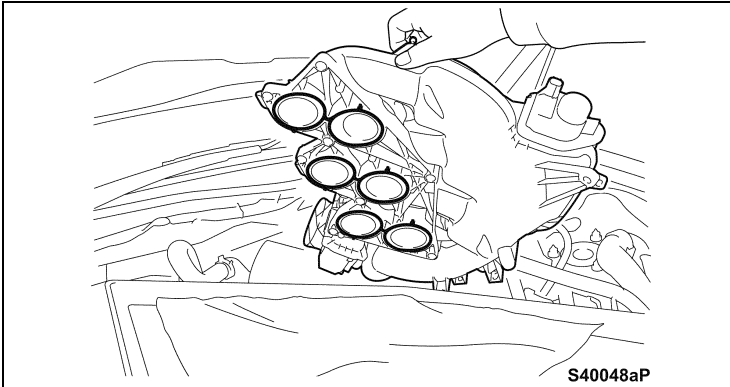

2. REINSTALL THE AIR SURGE TANK

- a) Install a NEW gasket onto the air surge tank.

NOTE: DO NOT place the air surge tank in a vertical position as oil may leak out of the t-body.

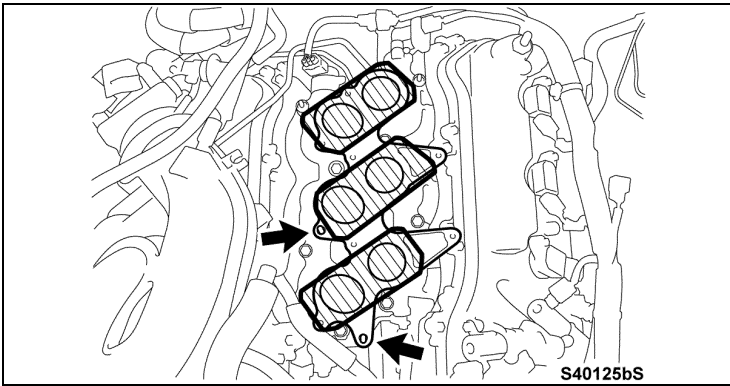

- a) Check the torque of the 2 studs.
Torque: 4 Nm (41 kpf-cm, 35 in-lbs)
- b) Remove the protective tape from the intake ports.
- c) Clean the gasket surface area.

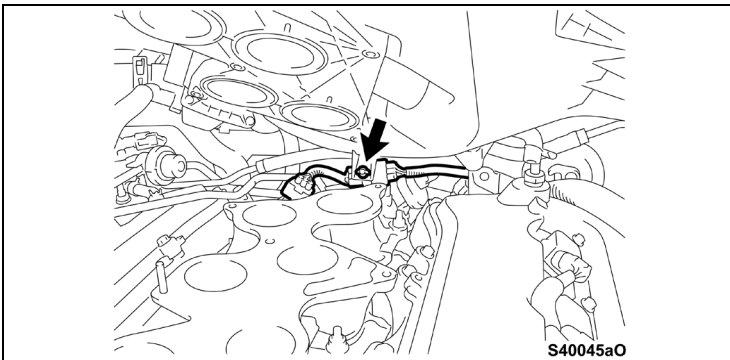

- d) Re-attach the SCV position sensor connector clamp to the surge tank.

- e) Carefully reinstall the air surge tank, being careful not damage the gasket on the studs for the tank.
- f) Check that the coolant hose for the t-body has not become disconnected and routed correctly.

Check for disconnection of the water hose.

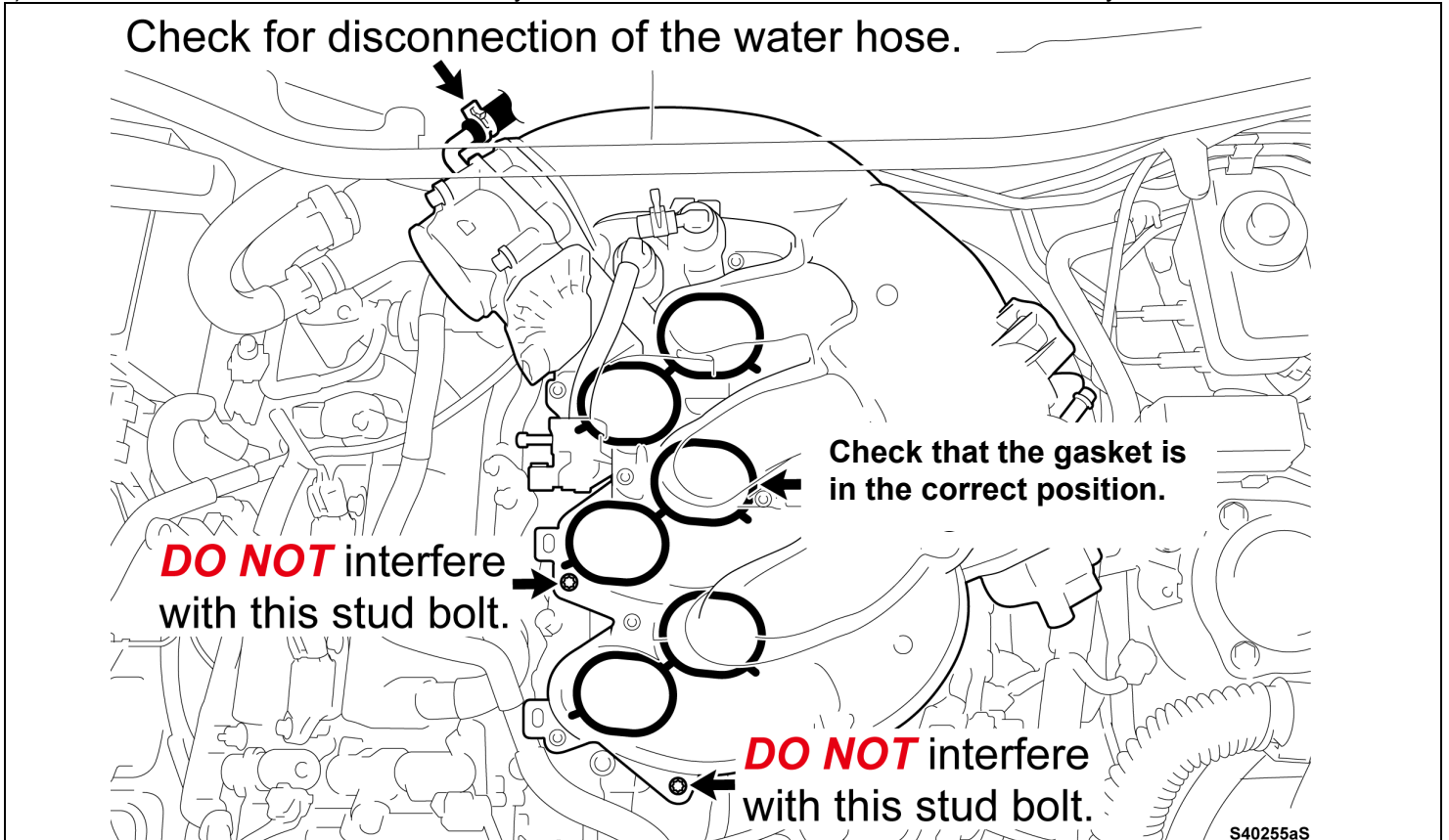

- g) Reconnect the ventilation hose.

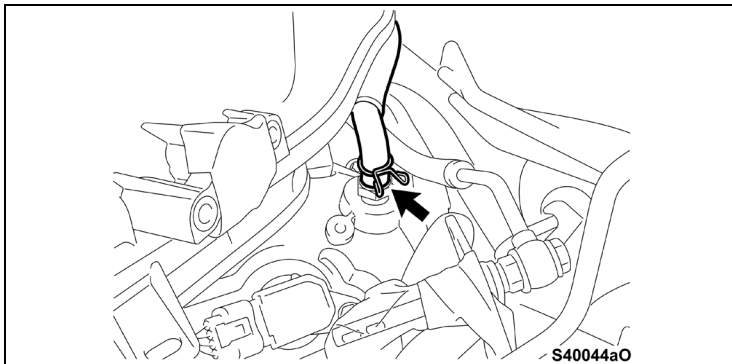

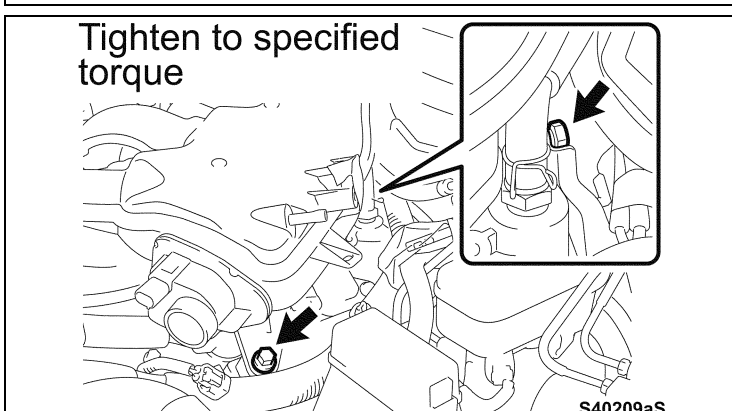
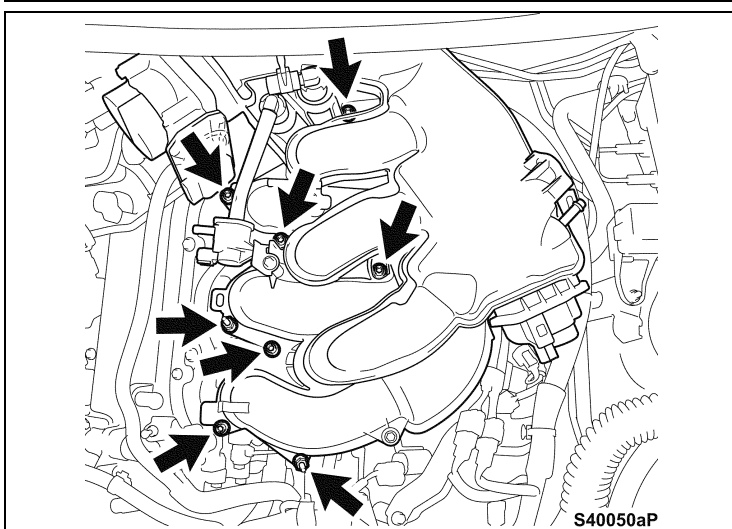
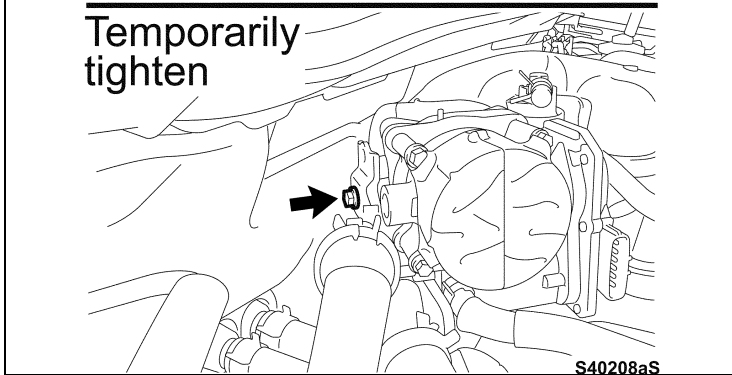
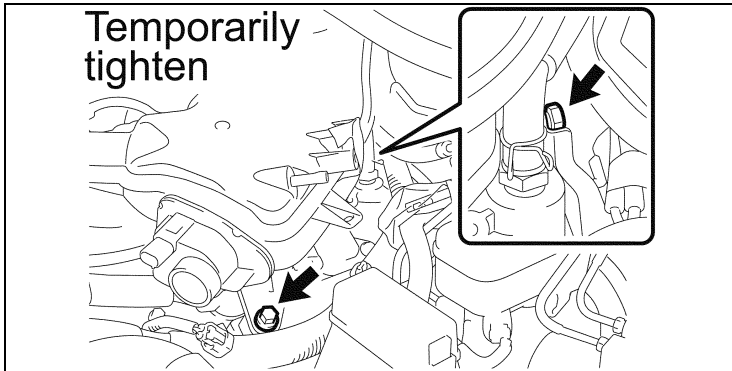

- h) Reinstall the 2 bolts to the sides of the surge tank.
 - i) Using the supplied box end ratchet wrench, temporarily tighten the bolt for the water pipe stay.
- NOTE: The parts above must be installed temporarily to align all the pieces prior to torquing the tank.**

- j) Reinstall the 7 bolts and 2 nuts for the air surge tank.
- Bolt Torque: 18 Nm (184 kpf-cm, 13 ft-lbs)**
- Nut Torque: 16 Nm (163 kpf-cm, 12 ft-lbs)**

- k) Tighten the 2 bolts on the side of the surge tank.
- Torque: 21 Nm (214 kpf-cm, 15 ft-lbs)**

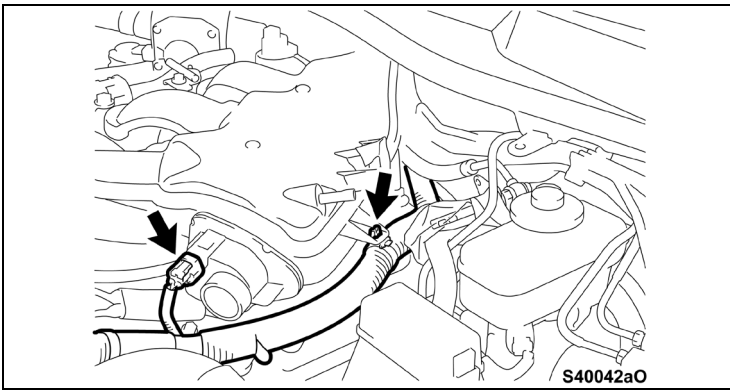

- l) Reconnect the connector.
- m) Reconnect the wire harness clamp.

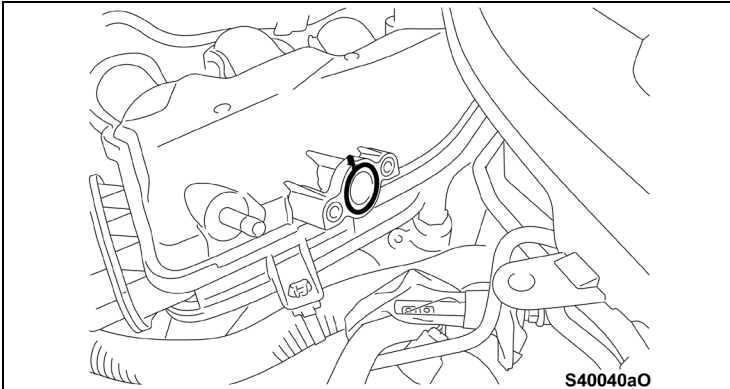

- n) Remove the tape from the cold start injector port.
- o) Install the NEW gasket for the cold start injector.

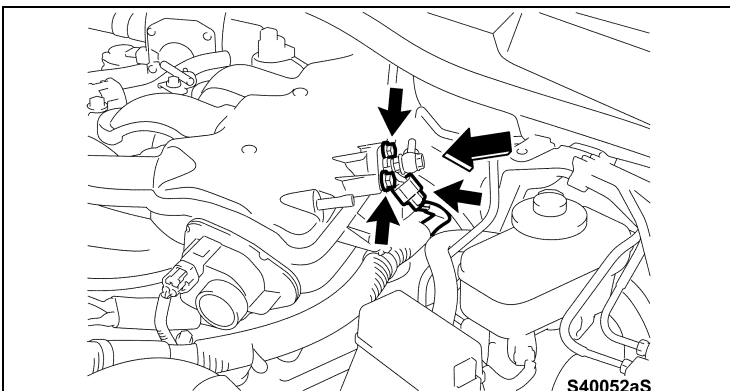

- p) Uncover the cold start injector.
- q) Reinstall the cold start injector with the 2 bolts.
Torque: 10 Nm (102 kpf-cm, 7 ft-lbs)
- r) Reconnect the cold start injector connector.

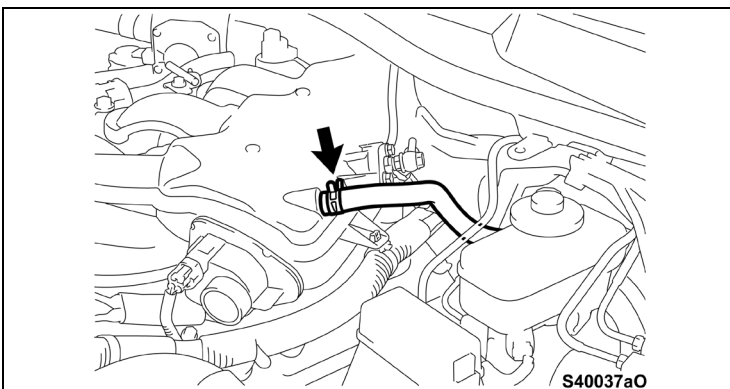

- s) Reconnect the union to check valve hose.

Tighten to specified torque

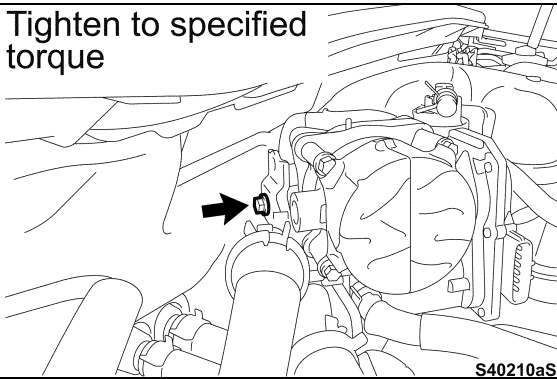

S40210aS

t) Tighten the bolt for the water pipe stay.

Torque: 10 Nm (102 kpf-cm, 7 ft-lbs)

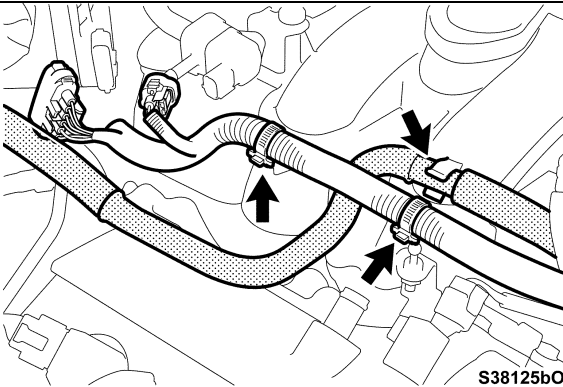

S38125bO

u) Reinstall the No.2 water by-pass hose and reinstall the wire harness clamp.

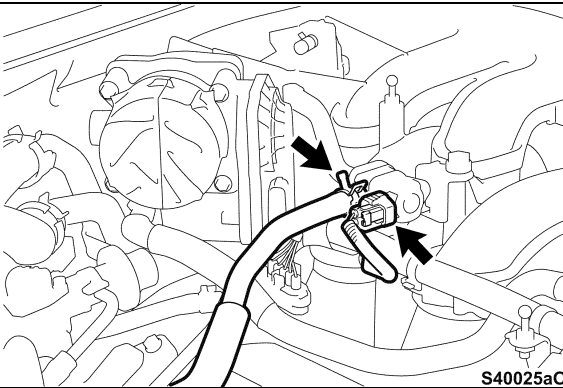

S40025aO

v) Reconnect the No.2 fuel vapor feed hose.

w) Reconnect the vacuum switching valve connector.

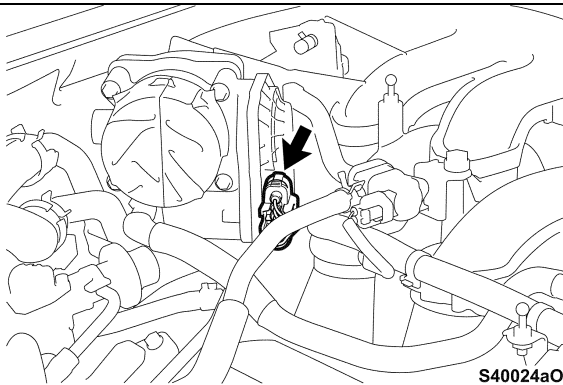

S40024aO

x) Reconnect the throttle body connector.

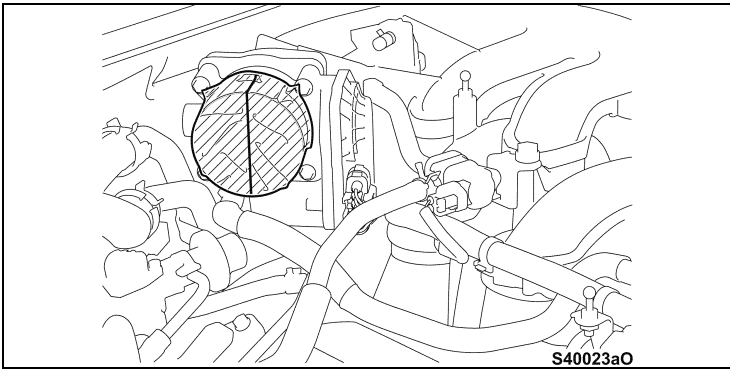

- y) Remove the protective tape.
- z) Clean the throttle body.

3. REINSTALL AIR CLEANER ASSEMBLY

- a) Reinstall the air filter.
- b) Reinstall the air cleaner assembly and hose.
- c) Reconnect the hose to the throttle body.
- d) Reconnect the MAF sensor.
- e) Reconnect the vent hose.
- f) Re-clip the hose.

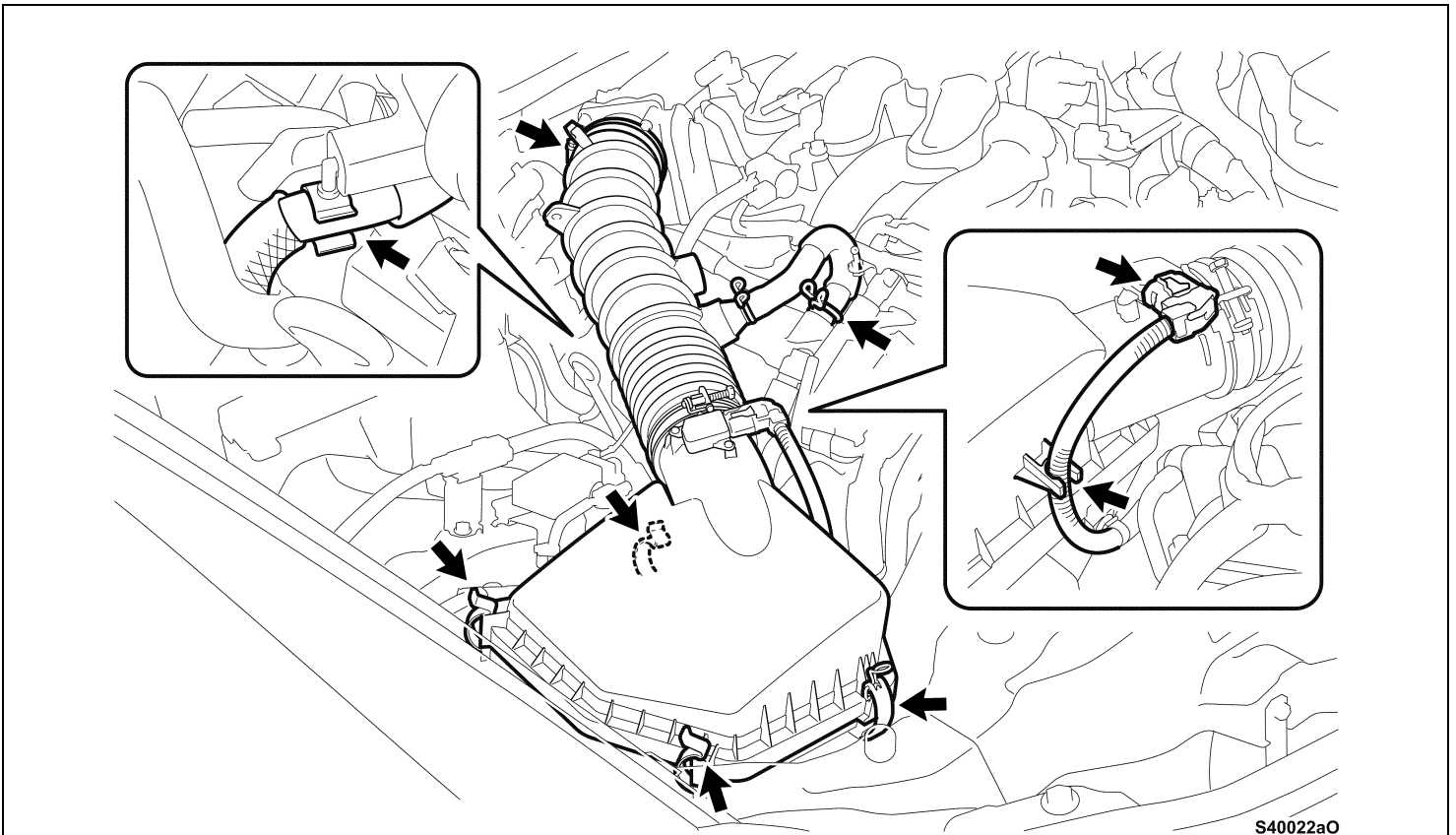

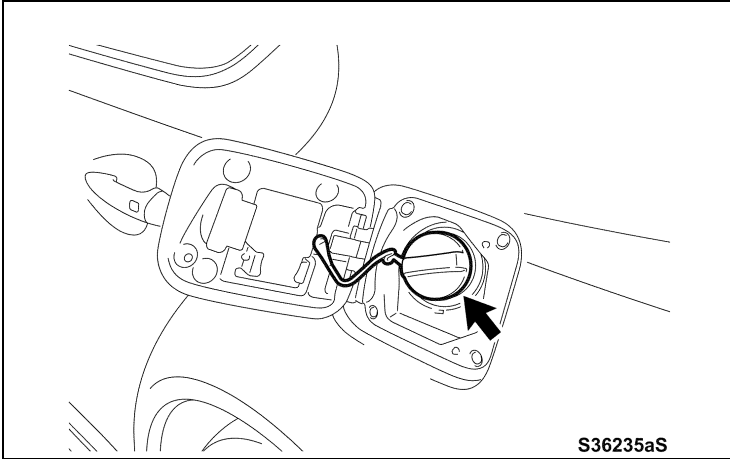

g) Reinstall the fuel cap.

4. RECONNECT THE NEGATIVE BATTERY CABLE

- a) Restore any memory settings and initialize any system needed (i.e. power windows, moonroof, etc.).

5. CHECK AND CLEAR DTC's

6. INSPECT THROTTLE BODY OPERATION

- a) Start the engine and check that the Check engine light is off.
- b) Allow the engine reach operating temperature.
- c) Make sure climate control system is off.
- d) Check that the idle is within specifications
600-700 RPM.

NOTE: All accessories, climate control and cooling fans must be off, and the transmission in P or N when performing this check.

- e) Quickly open the throttle to WOT and check that the Throttle Sensor Position reading is a minimum of 60 %.

7. TEST DRIVE VEHICLE

8. REINSTALL ENGINE ROOM COVERS

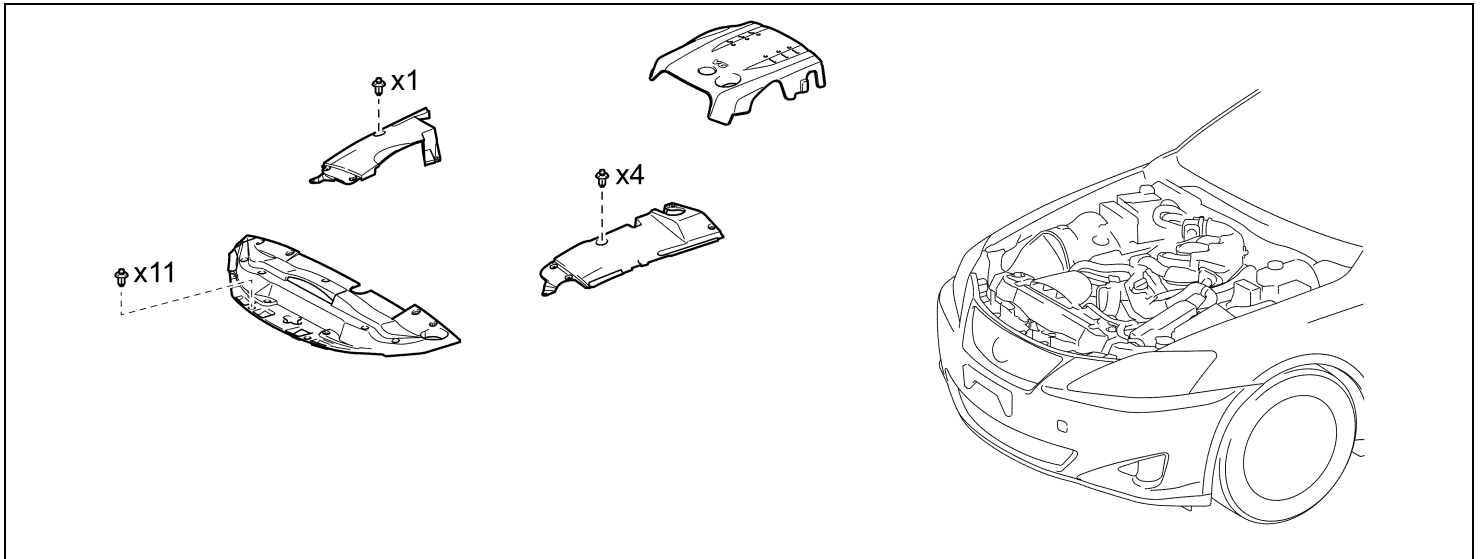

◀ VERIFY REPAIR QUALITY ▶

- Clear DTC's
- No fuel leaks or fuel smell

If you have any questions regarding this **recall**, please contact your regional representative.

IX. APPENDIX

CAMPAIGN DESIGNATION DECODER

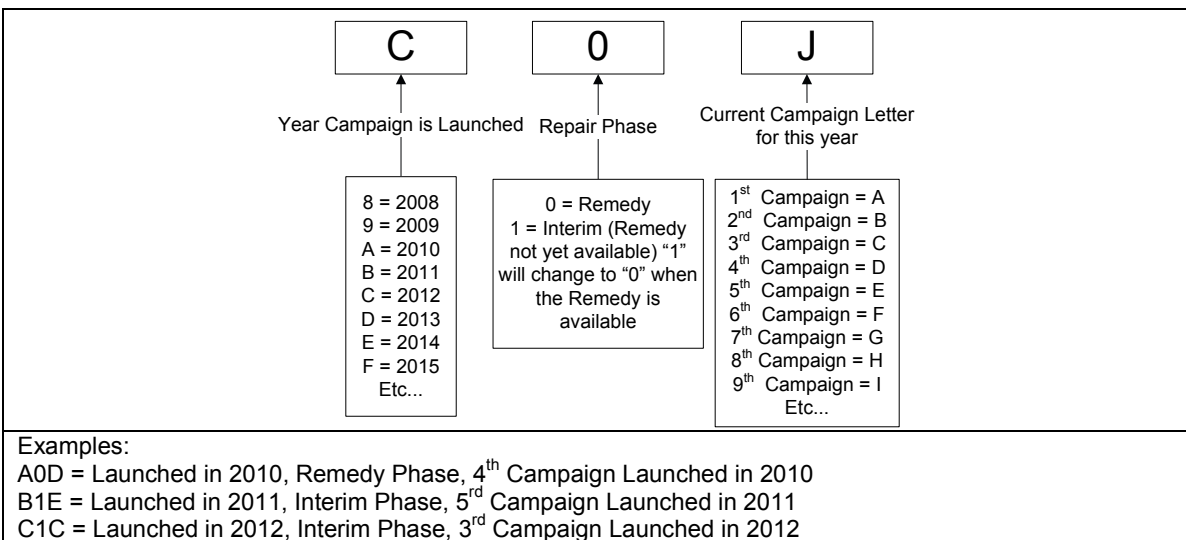

X. REMOVED PARTS

As required by Federal Regulations, please make sure all recalled parts (original parts) removed from the vehicle are disposed of in a manner in which they will not be reused, **unless requested for parts recovery return.**