

# Front Fog Light

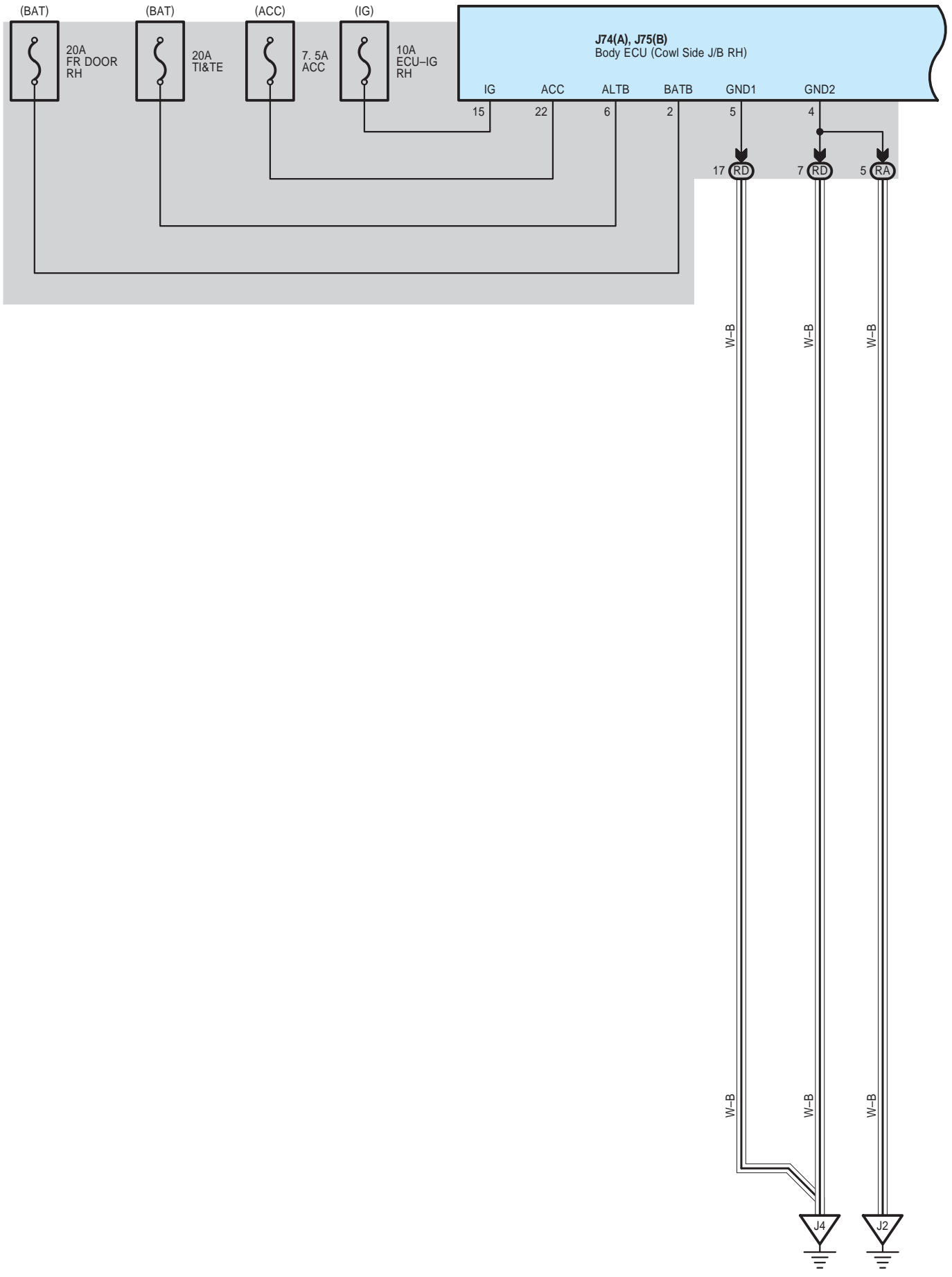

**J74(A), J75(B)**  
Body ECU (Cowl Side J/B RH)

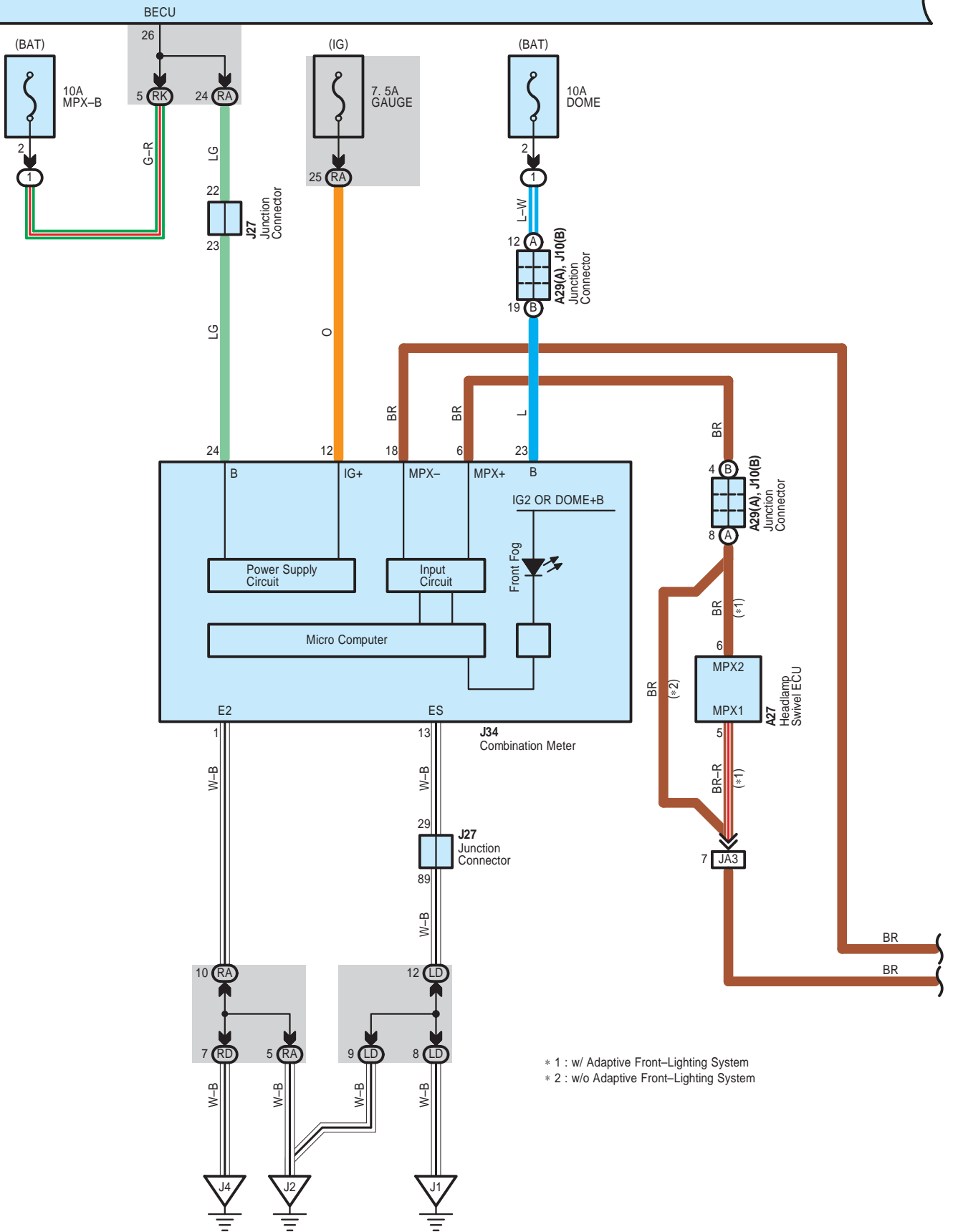

\* 1 : w/ Adaptive Front-Lighting System  
\* 2 : w/o Adaptive Front-Lighting System



**J74(A), J75(B)**  
Body ECU (Cowl Side J/B RH)

\* 3 : w/ Tire Pressure Warning System  
 \* 4 : w/o Tire Pressure Warning System

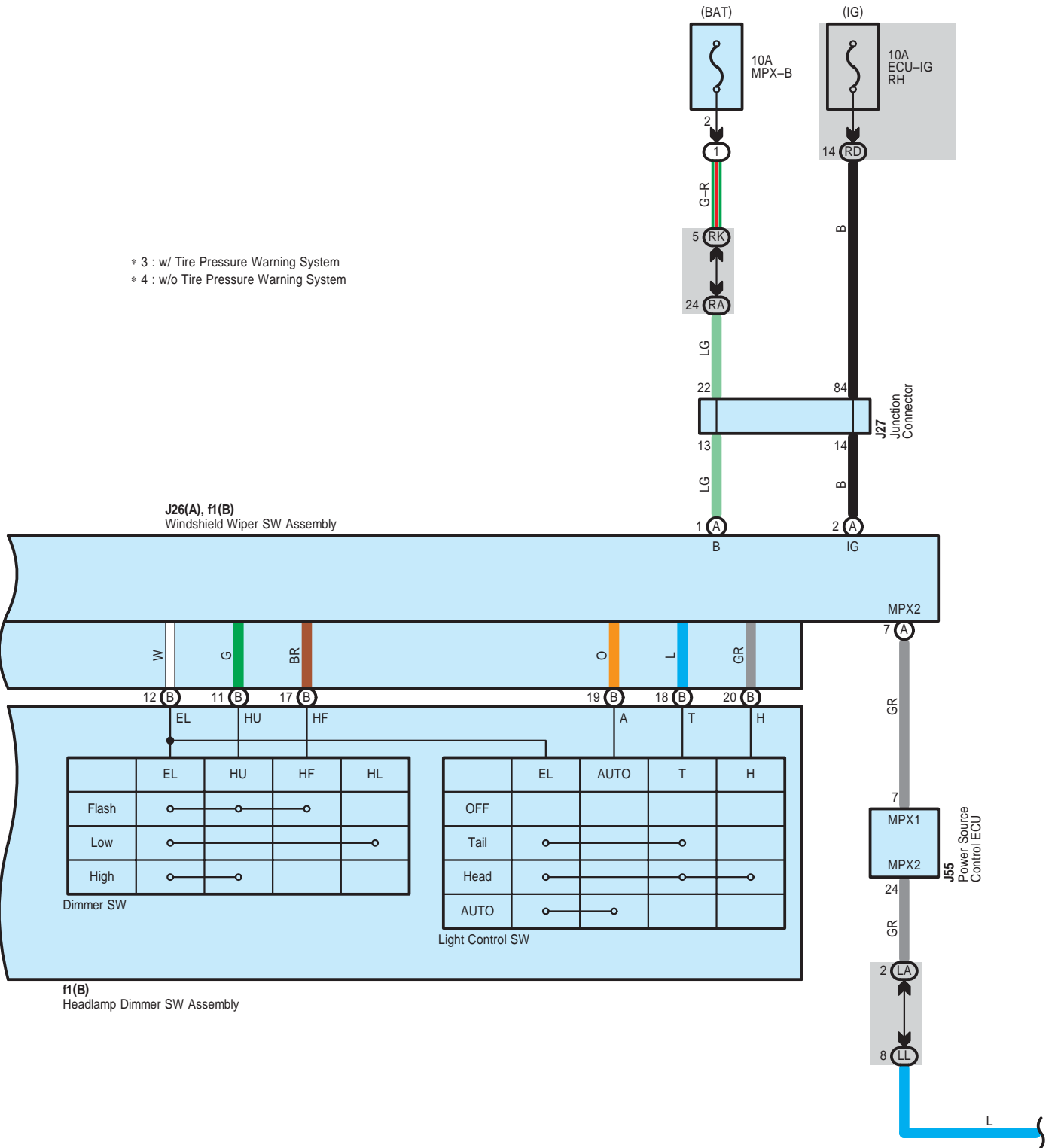

# Front Fog Light

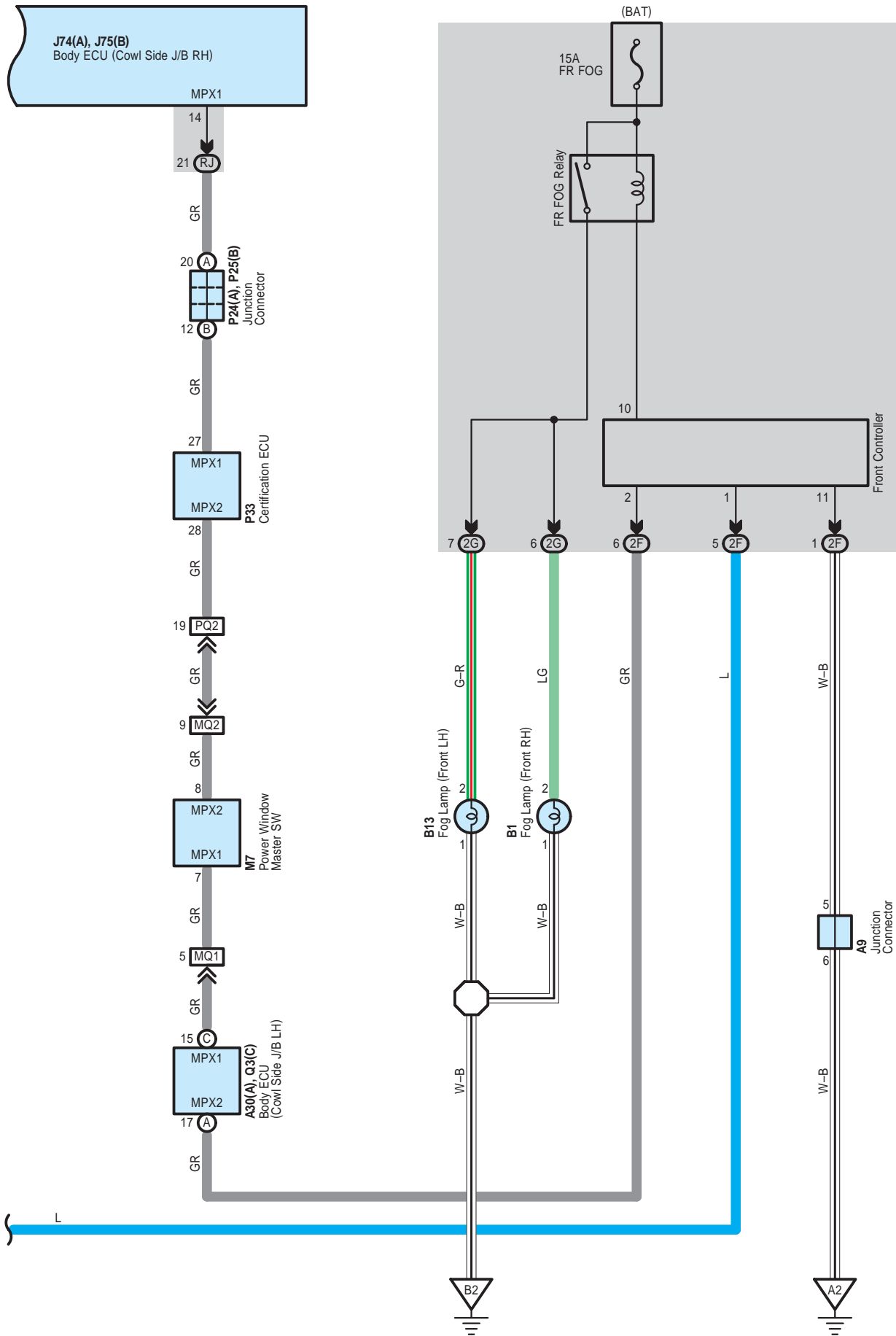

 : **Parts Location**

Code	See Page	Code	See Page	Code	See Page	
A9	50 (2GR-FSE)	B13	55 (4GR-FSE)	J75	B 60	
	54 (4GR-FSE)	J10	B	58	J76 60	
A27	61	J26	A	58	J80	B 60
A29	A 61	J27	58	M7	62	
A30	A 61	J34	59	P24	A 63	
A33	A 61	J49	59	P25	B 63	
B1	51 (2GR-FSE)	J55	59	P33	63	
	55 (4GR-FSE)	J58	59	Q3	C 61	
B13	51 (2GR-FSE)	J74	A	60	f1	B 61

 : **Relay Blocks**

Code	See Page	Relay Blocks (Relay Block Location)
1	22	Engine Room R/B No.1 (Near the Battery)

 : **Junction Block and Wire Harness Connector**

Code	See Page	Junction Block and Wire Harness (Connector Location)
2F	27	Engine Room Main Wire and Engine Room J/B No.2 (Engine Compartment Left)
2G	27	Engine Room No.2 Wire and Engine Room J/B No.2 (Engine Compartment Left)
LA	35	Instrument Panel Wire and Cowl Side J/B LH (Cowl Side Left)
LD		
LL	36	Engine Room Main Wire and Cowl Side J/B LH (Cowl Side Left)
RA	41	Instrument Panel Wire and Cowl Side J/B RH (Cowl Side Right)
RD		
RJ	42	Floor No.1 Wire and Cowl Side J/B RH (Cowl Side Right)
RK	42	Engine Room Main Wire and Cowl Side J/B RH (Cowl Side Right)

 : **Connector Joining Wire Harness and Wire Harness**

Code	See Page	Joining Wire Harness and Wire Harness (Connector Location)
JA3	70	Instrument Panel Wire and Engine Room Main Wire (Left Kick Panel)
JA4	70	Instrument Panel Wire and Engine Room Main Wire (Right Kick Panel)
MQ1	70	Front Door LH Wire and Floor No.2 Wire (Cowl Side Panel LH)
MQ2		
PQ2	71	Floor No.1 Wire and Floor No.2 Wire (Right Side of the Rear Floor Partition Panel)

 : **Ground Points**

Code	See Page	Ground Points Location
A2	68 (2GR-FSE)	Rear Side of the Left Fender Apron
	69 (4GR-FSE)	
B2	68 (2GR-FSE)	Front Side of the Left Fender Apron
	69 (4GR-FSE)	
J1	70	Left Kick Panel
J2	70	Left Side of the Shift Lever
J4	70	Right Kick Panel