

Fig. 5-1

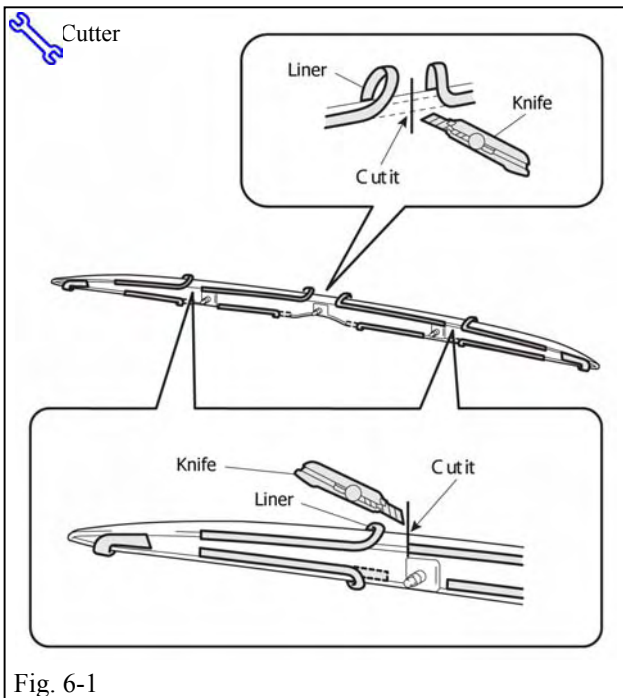

Fig. 6-1

5. Degrease the Luggage Door Panel.

- (a) Use genuine wax remover to degrease the hatched area.



- (1) After degreasing the areas, do not touch them.

6. Rear Spoiler Installation.

- (a) To dispose of liner, start by using a cutter, and making a cut in the vehicle center area of the adhesive tape liner at the top of the rear spoiler, peel away the liner about 30 mm to each side. Then, use masking tape to secure the ends of the liner to the outer surface. (Fig. 6-1)



- (1) Wear Kevlar gloves before using a cutter.
- (b) Following the procedure as shown, use a cutter to make a cut in the adhesive tape liner at the top of the rear spoiler, at the outer side of the bolt (RH and LH). Peel the liner about 30 mm only towards the outer side of the vehicle, and use masking tape to secure the ends to the outer surface. . (Fig. 6-1)
- (c) Peel each of the two adhesive tape liners (RH and LH) at the bottom of the rear spoiler about 30 mm outward from the center, and use masking tape to secure the ends to the outer surface. (Fig. 6-1)
- (d) Peel the one adhesive tape liner (RH and LH) at the rear spoiler about 30 mm downward from the outer side, and use masking tape to secure the ends to outer surface. (Fig. 6-1)

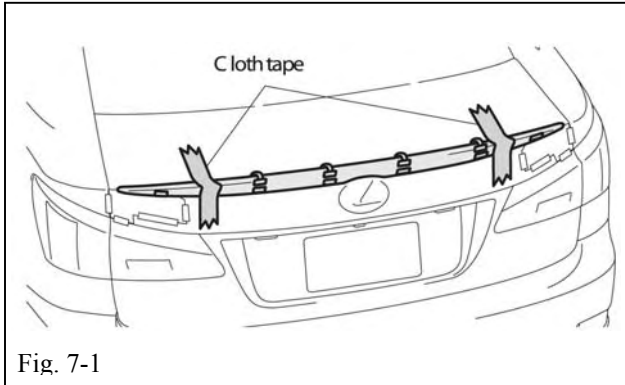

Fig. 7-1

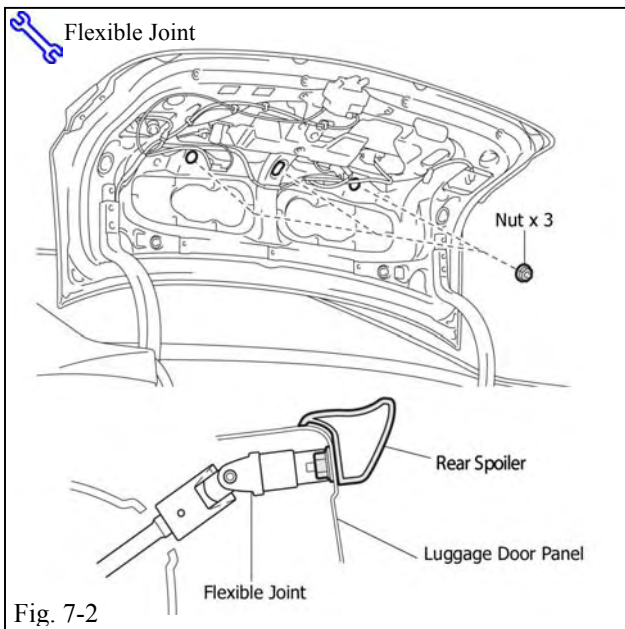

Fig. 7-2

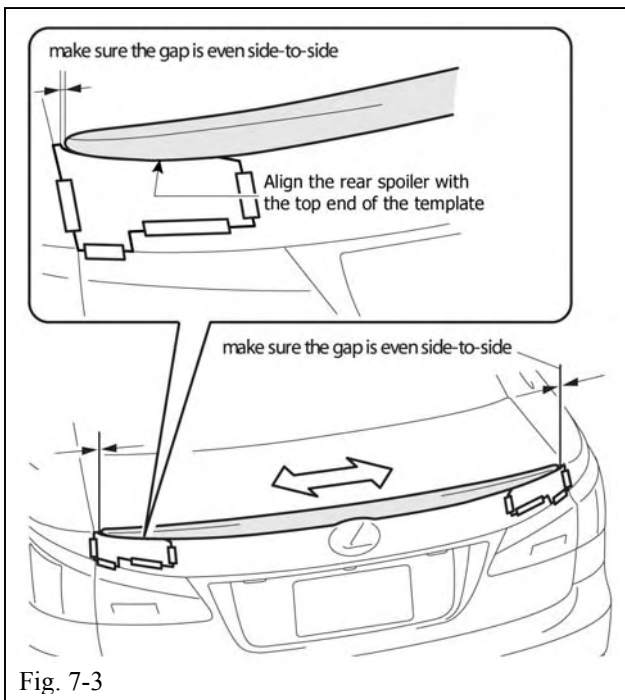

Fig. 7-3

7. Rear Spoiler Installation.

- (a) Align and insert the three bolts of the rear spoiler into the installation holes of the luggage door panel. Secure them with cloth tape to prevent them from falling.
- (b) Temporarily tighten the rear spoiler with three nuts.



- (1) A straight box wrench cannot be used to tighten the nuts, instead, use a flexible joint.
- (c) Remove the cloth tape that is used to secure the rear spoiler in place.
- (d) Following the procedure as shown, check the dimension between the parting line of the luggage door and each end of the rear spoiler. Then, adjust the installation position in the lateral direction. (Fig. 7-3)

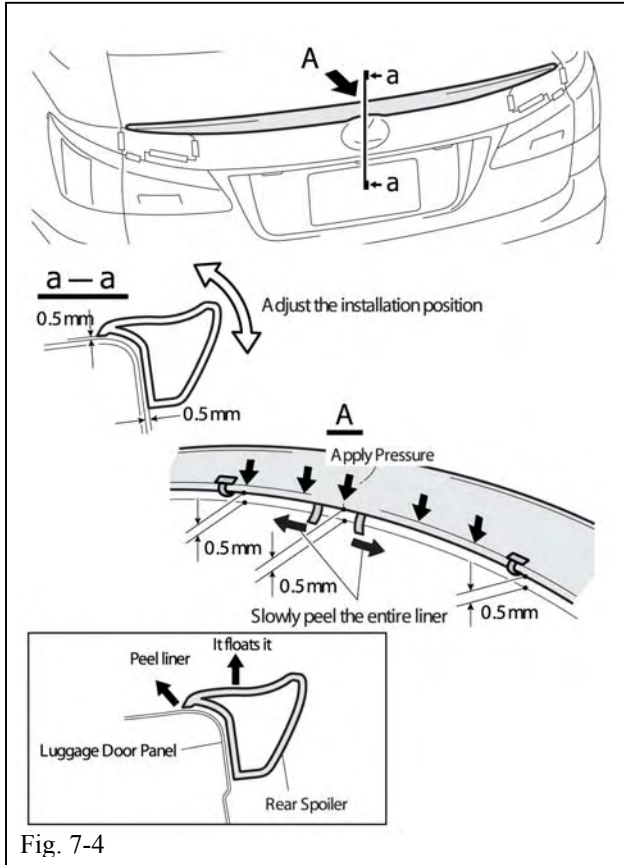

(e) Following the procedure shown on the left, adjust the position of the rear spoiler. Peel the liner from the top of the vehicle center (RH and LH) and press the adhesive tape. (Fig. 7-4)



(1) Pull the liner while raising the rear spoiler, without allowing the liner to tear in the middle.



(2) Apply a minimum pressure of 49 N to affix the adhesive tape. Otherwise, the adhesive tape could come loose and create a gap.

(f) Peel the liner from the back of the vehicle center (RH and LH) and press the adhesive tape. (Fig. 7-5)



(1) Pull the liner while raising the rear spoiler, without allowing the liner to tear in the middle.



(2) Apply a minimum pressure of 49 N to affix the adhesive tape. Otherwise, the adhesive tape could come loose and create a gap.

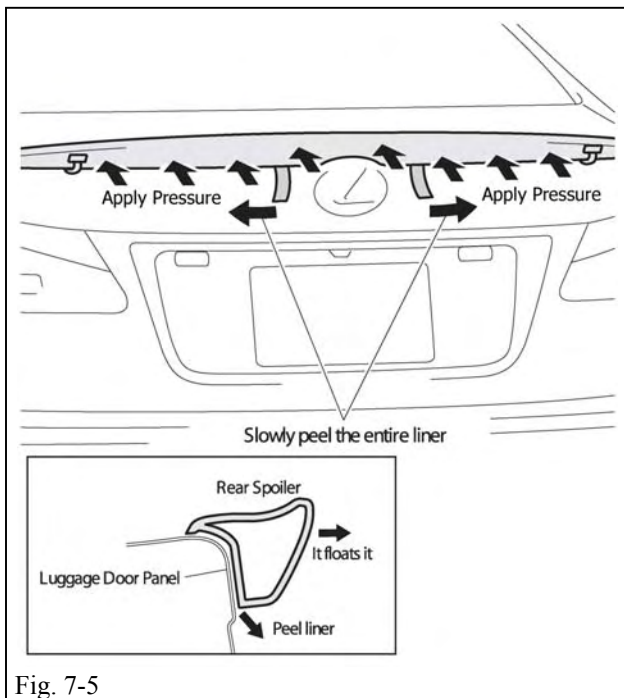

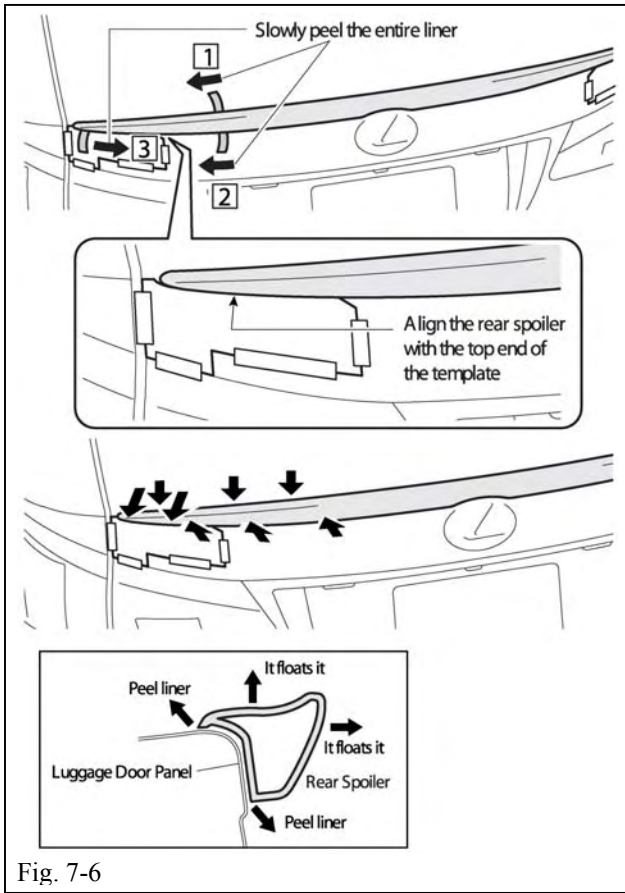

Fig. 7-6

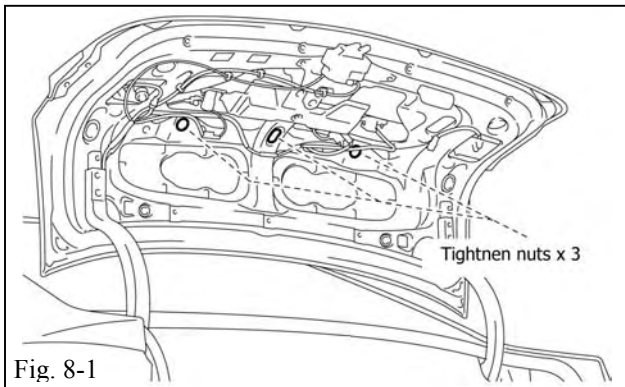

Fig. 8-1

(g) Align the bottom end of the rear spoiler against the top end of the template. Following procedures 1, 2, and 3 as shown, peel the liner and press the adhesive tape. (Fig. 7-6)

(1) Pull the liner while raising the rear spoiler, without allowing the liner to tear in the middle.

(2) Apply a minimum pressure of 49 N to affix the adhesive tape. Otherwise, the adhesive tape could come loose and create a gap.

(h) Repeat the operation on the RH side in the same manner.

8. Tightening the Rear Spoiler.

(a) Fully tighten the three nuts that were tightened temporarily, starting with the center nut and working outward. (Fig. 8-1)

9. Installing the Vehicle Parts.

(a) Install the luggage door trim that was removed. The installation sequence is the opposite of removal of the vehicle parts.

(b) Attach the negative (-) terminal to the battery.

10. Precaution for Reconnecting Battery.

 (a) Some functional parts of the vehicle must be initialized upon reconnecting battery. Make sure to initialize them upon reconnecting the battery.

11. Verifying the Installation.

(a) Check that the rear spoiler is secured properly to the luggage door panel.

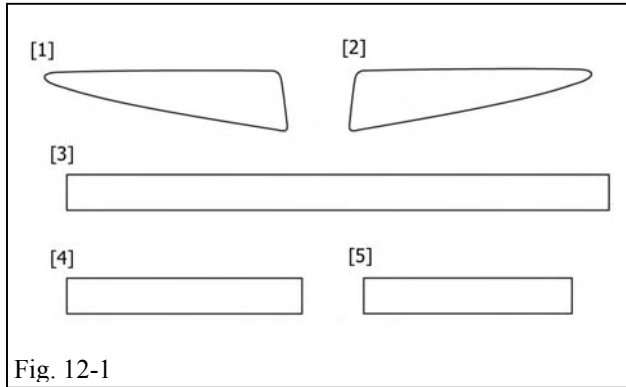

Fig. 12-1

- (b) Check that all the backing sheets are removed from the adhesive tapes, and that the adhesive tapes are affixed securely.
- (c) Check that the rear spoiler and the vehicle parts did not get scratched during the installation.



NOTE: Make sure the rear spoiler is not exposed to water for 20 minutes after the installation. Otherwise, the adhesive tape could peel and create a gap between the luggage door panel and the rear spoiler.

12. Handling Repair Parts.

- (a) Installation parts (Fig. 12-1):
 - (1) Adhesive tape RH
 - (2) Adhesive tape LH
 - (3) Adhesive tape A [8 x 994 mm t 1.6]
 - (4) Adhesive tape B [8 x 220 mm t 1.6] x 2
 - (5) Adhesive tape C [8 x 208 mm t 1.6] x 2

13. Painting the Spoiler.

- (a) Paint the spoiler using the a-a cross section as reference.
- (b) Degrease the area to which adhesive tape is to be affixed.
- (c) Using the b-b cross section as a reference, affix the RH and LH sides of the adhesive tape so that they are uniformly 1 mm away from the concave intersection of the rear spoiler.
- (d) Using the a-a cross section and the dimensions in the illustration as references, affix adhesive tape A, B, and C.
- (e) Apply a minimum pressure of 49N to the affixed protector.

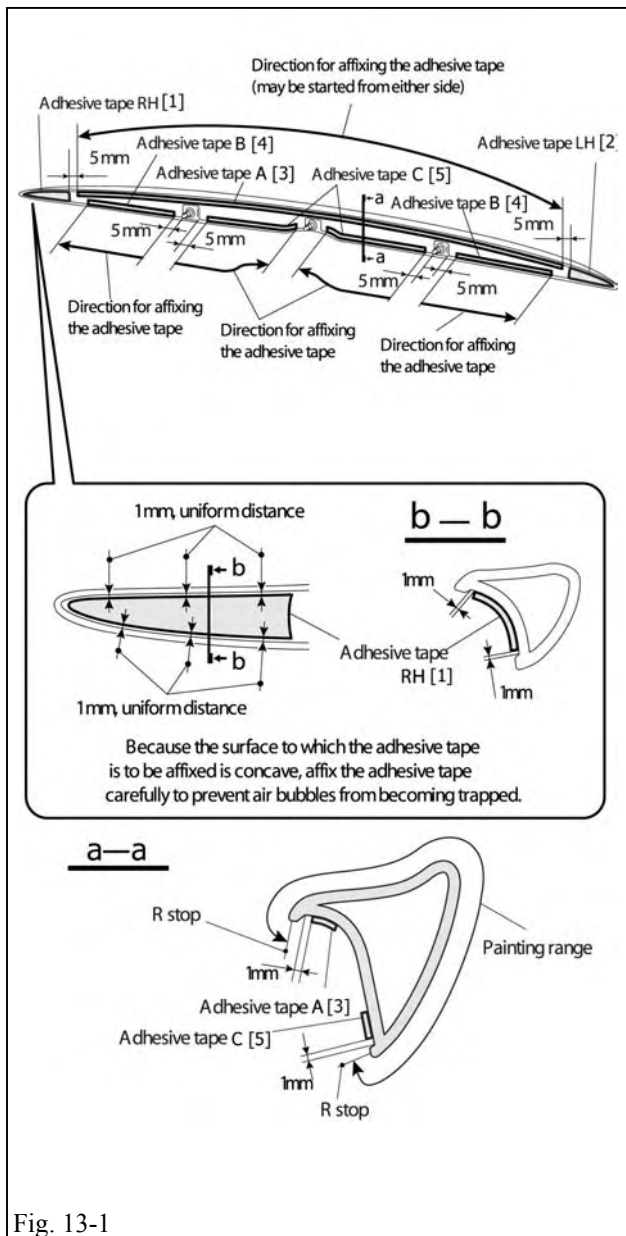

Fig. 13-1

Checklist - these points **MUST** be checked to ensure a quality installation.

Check:

Look For:

Accessory Function Checks

- Check for spoiler alignment
- Check for full tape adhesion

Centered from side to side (± 2 mm)
Full adhesion with no gaps.

Vehicle Function Checks

- None Required