

| | | |
|--|--------------|-------------------------------|
| Last Modified: 03-31-2015 | 6.6 A | Doc ID: RM1000000006IJP |
| Model Year: 2014 | Model: IS250 | Prod Date Range: [04/2013 -] |
| Title: EXTERIOR PANELS / TRIM: REAR BUMPER: DISASSEMBLY; 2014 - 2015 MY IS250 IS350 [04/2013 -] | | |

DISASSEMBLY

PROCEDURE

1. REMOVE REAR BUMPER PAD

(a) Remove the rear bumper pad.

HINT:

Use the same procedure for the RH side and LH side.



2. REMOVE REAR BUMPER PIECE

(a) Disengage the 2 claws.

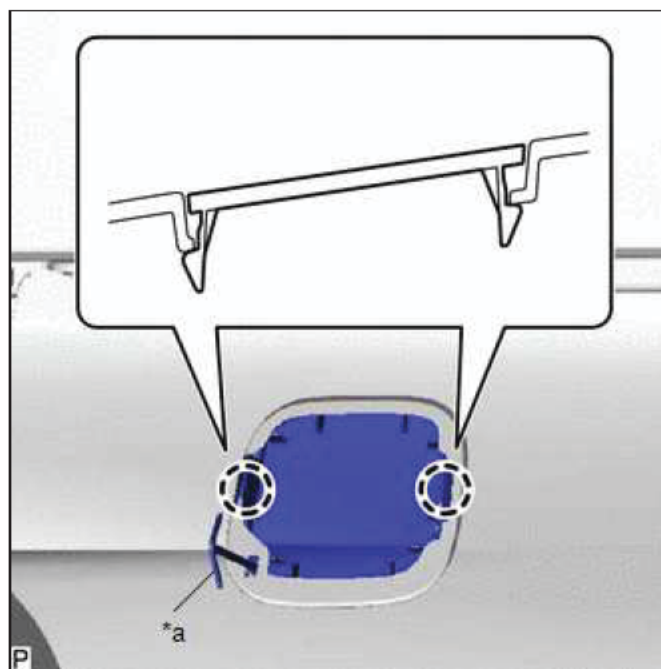

*a

Hook

(b) Disengage the hook to remove the rear bumper piece.

3. REMOVE REFLEX REFLECTOR ASSEMBLY LH

(a) Install the screw.

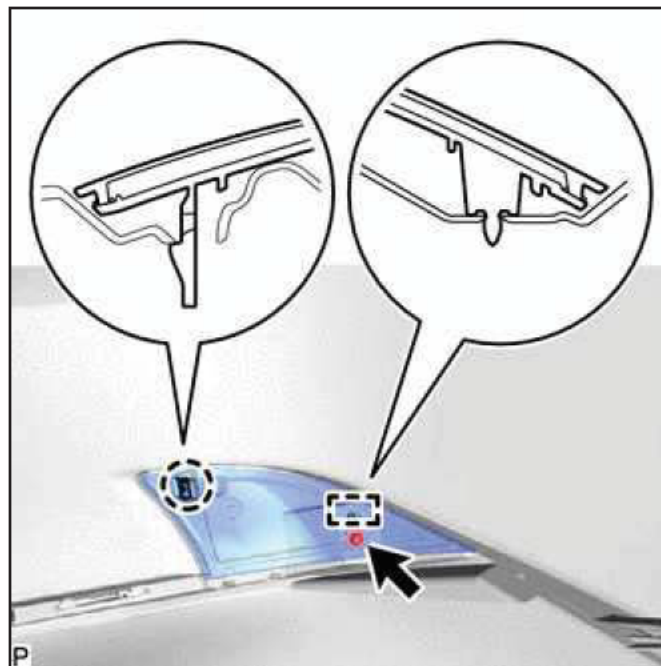

(b) Disengage claw and guide, and remove the reflex reflector assembly LH.

4. REMOVE REFLEX REFLECTOR ASSEMBLY RH

HINT:

Use the same procedure as for the LH side.

5. REMOVE REAR LOWER BUMPER COVER

(a) Remove the 2 screws.

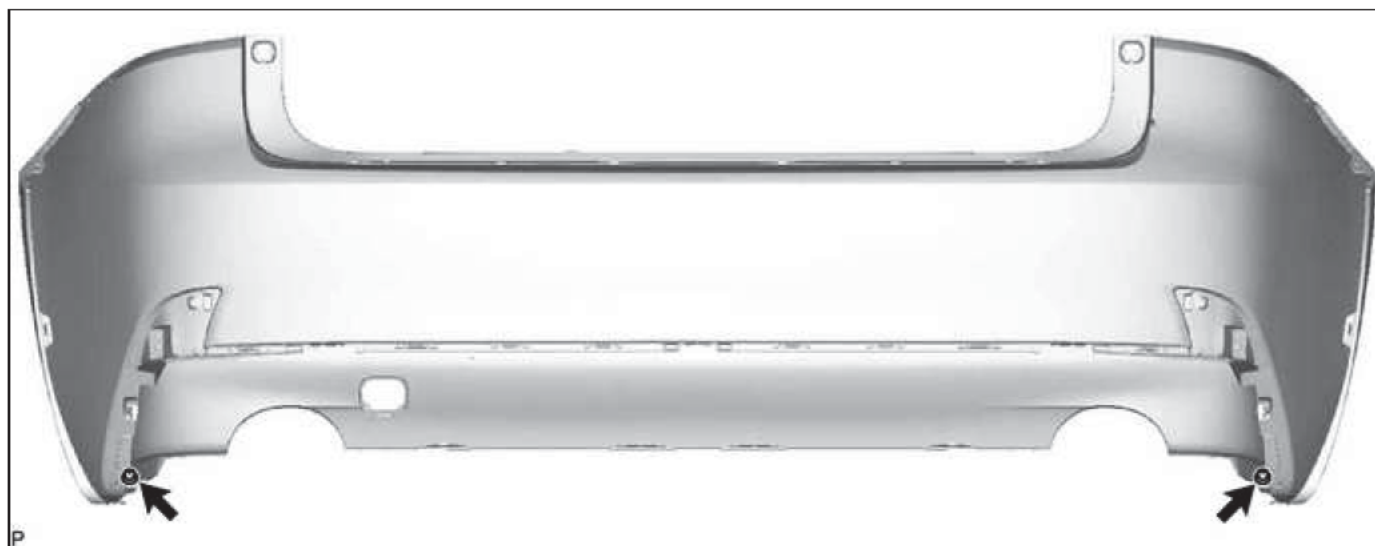

(b) Remove the 5 clips.

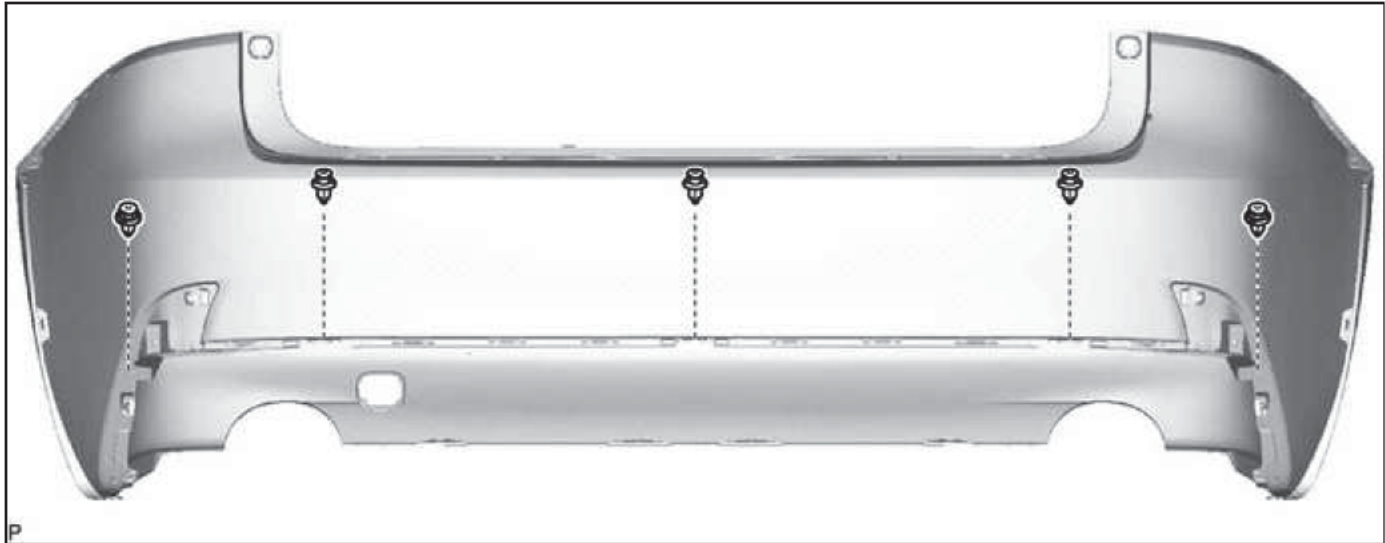

(c) Disengage the 10 claws and 2 guides, and remove the lower bumper cover.

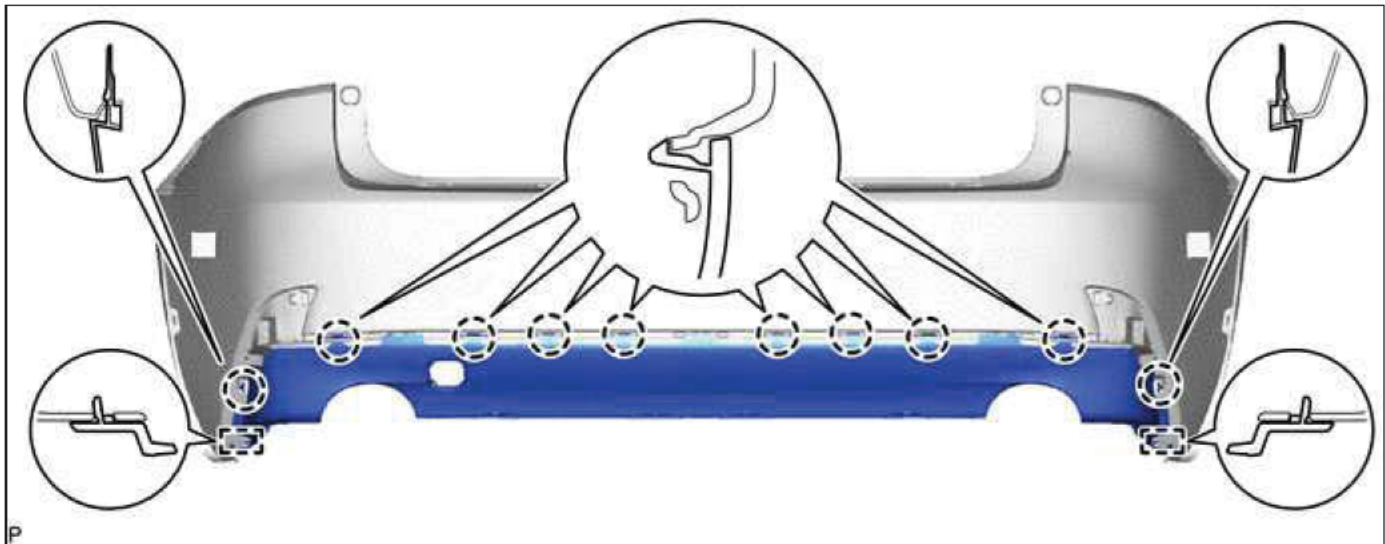

6. REMOVE NO. 3 LUGGAGE ROOM WIRE (w/ Intuitive Parking Assist System)

(a) Disengage the 4 clamps.

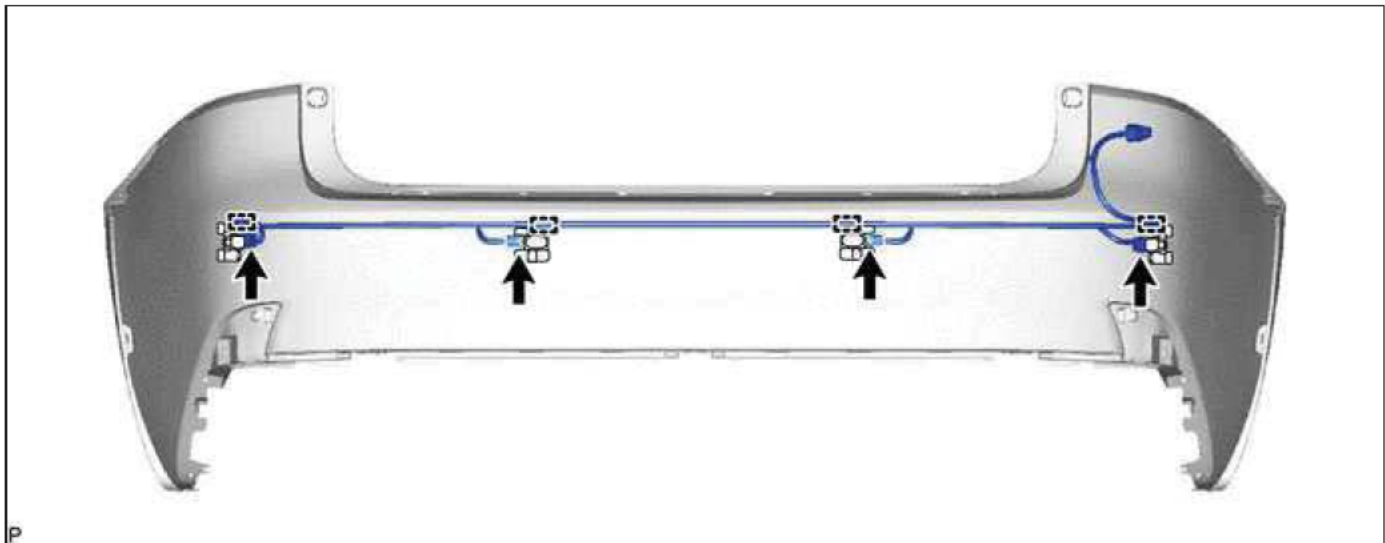

(b) Disconnect the 4 connectors to remove the No. 3 luggage room wire.

7. REMOVE ULTRASONIC SENSOR WITH CLIP (w/ Intuitive Parking Assist System)

Click here [INFO](#)

HINT:

Use the same procedure for all ultrasonic sensor with clips.

8. REMOVE NO. 1 ULTRASONIC SENSOR RETAINER (w/ Intuitive Parking Assist System)

Click here [INFO](#)

HINT:

Use the same procedure for all No. 1 ultrasonic sensor retainers.

9. REMOVE REAR LIGHT COVER (for LH Side)

Click here [INFO](#)

10. REMOVE REAR COMBINATION LIGHT ASSEMBLY LH

Click here [INFO](#)

11. REMOVE REAR LIGHT COVER (for RH Side)

HINT:

Use the same procedure as for the LH side.

12. REMOVE REAR COMBINATION LIGHT ASSEMBLY RH

HINT:

Use the same procedure as for the LH side.

13. REMOVE REAR BUMPER UPPER RETAINER LH

Click here [INFO](#)

14. REMOVE REAR BUMPER UPPER RETAINER RH

HINT:

Use the same procedure as for the LH side.

15. REMOVE NO. 2 REAR BUMPER SIDE SUPPORT LH

(a) Using a screwdriver, disengage the 3 clips as shown in the illustration.

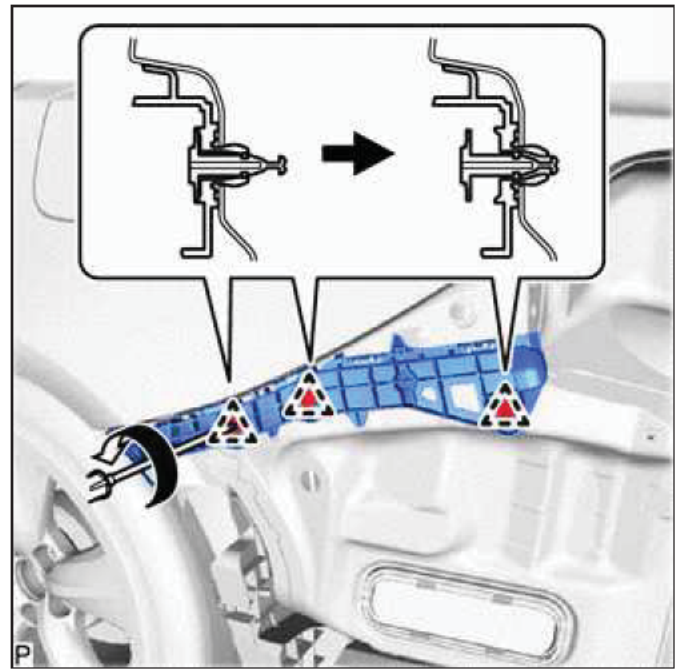

(b) Disengage the 4 claws and remove the No. 2 rear bumper side support LH.

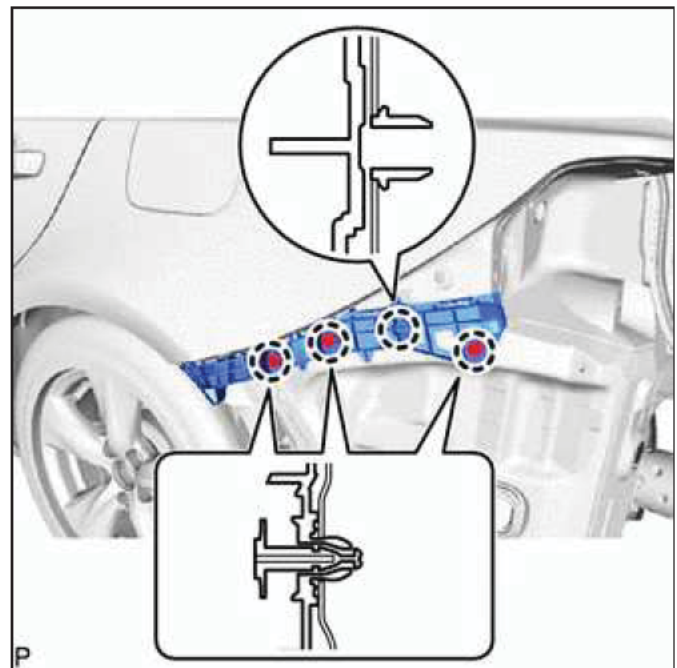

16. REMOVE NO. 2 REAR BUMPER SIDE SUPPORT RH

HINT:

Use the same procedure as for the LH side.

17. REMOVE NO. 1 REAR BUMPER SIDE SUPPORT LH

(a) Remove the grommet.

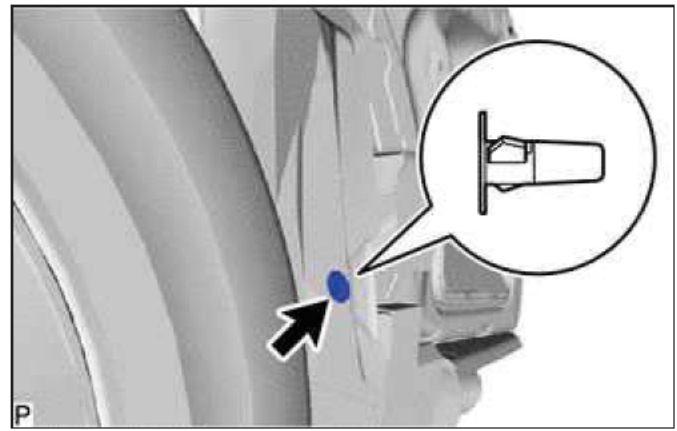

(b) Remove the 2 screws.

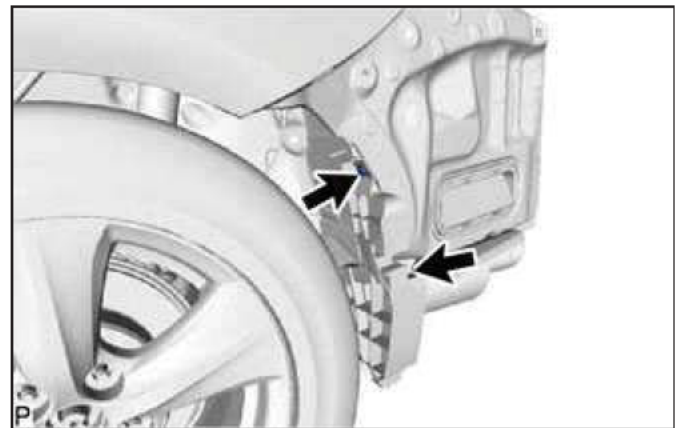

(c) Disengage the guide and claw to remove the No. 1 rear bumper side support LH.

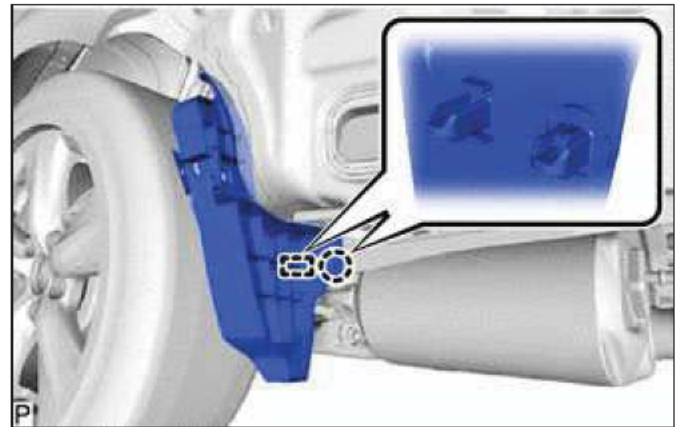

18. REMOVE NO. 1 REAR BUMPER SIDE SUPPORT RH

HINT:

Use the same procedure as for the LH side.

19. REMOVE REAR BUMPER ENERGY ABSORBER

(a) Disengage the 2 guides to remove the rear bumper energy absorber.

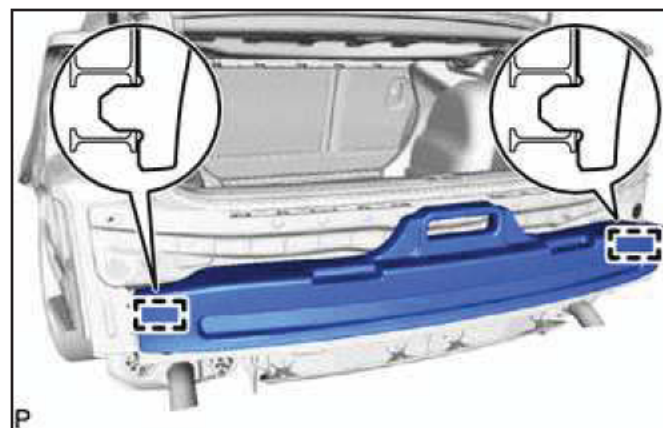

20. REMOVE REAR BUMPER REINFORCEMENT SUB-ASSEMBLY



(a) Remove the 8 bolts to rear bumper reinforcement sub-assembly.

