

T40(A), T41(C), T49(B)
Stereo Component Amplifier Assembly

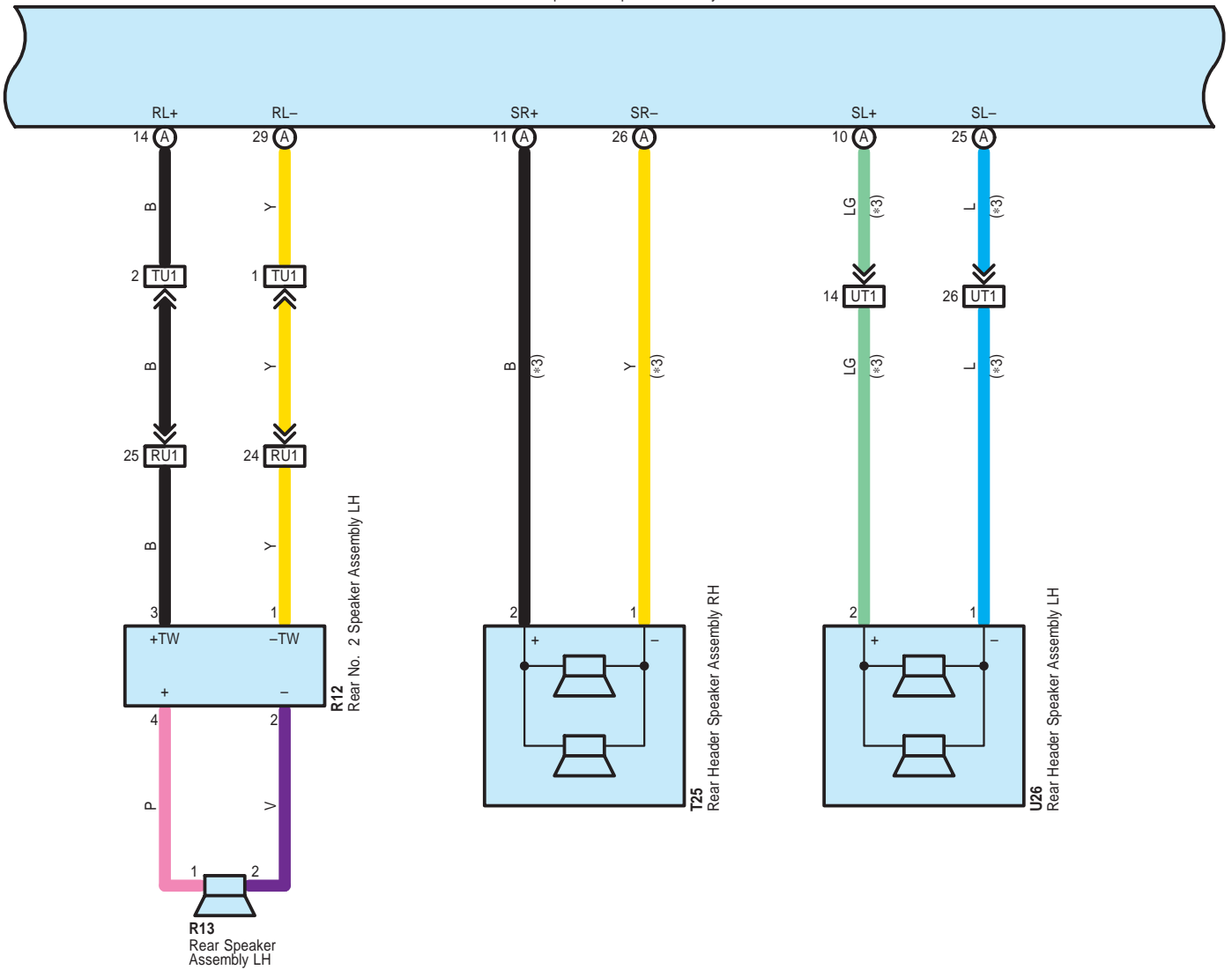

T40(A), T41(C), T49(B)
Stereo Component Amplifier Assembly

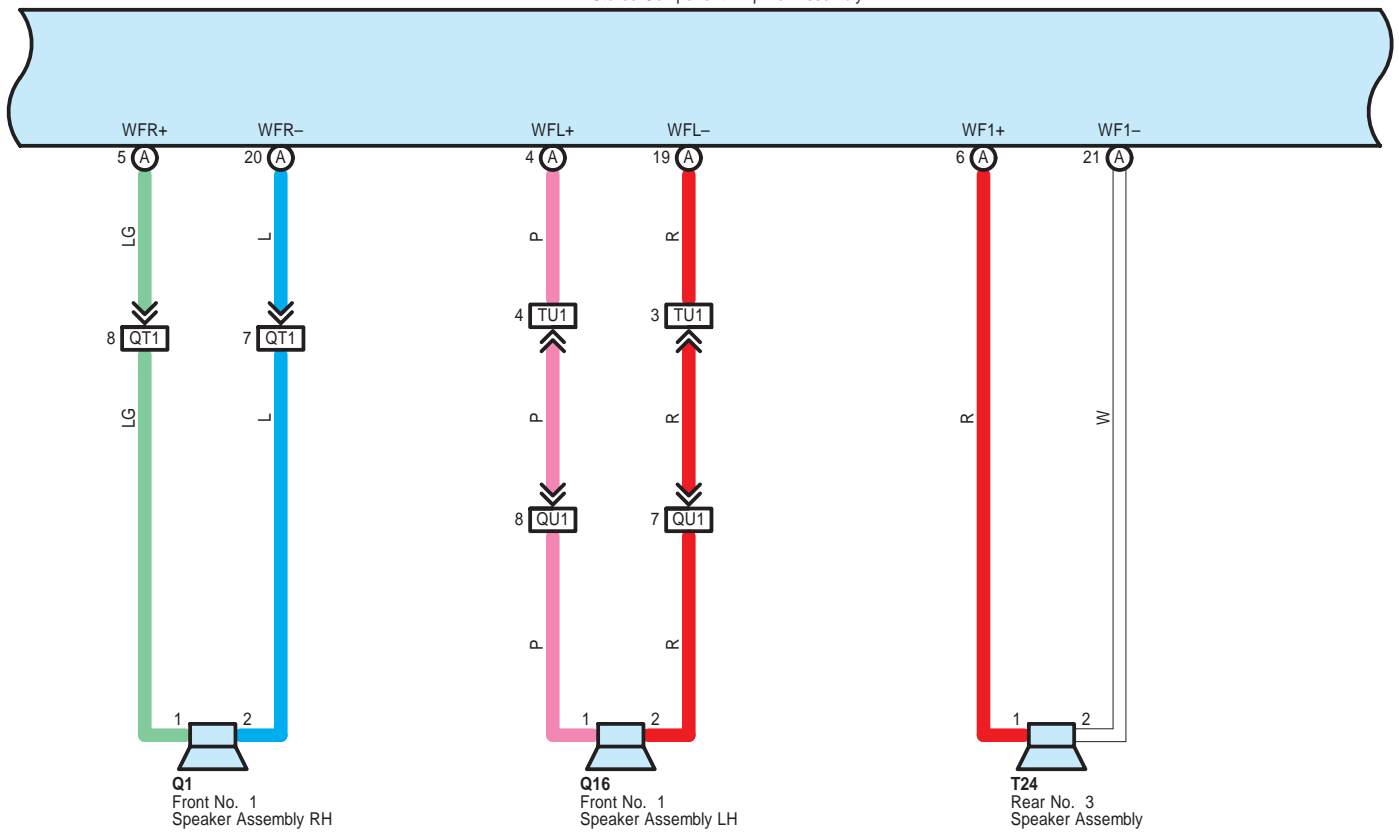

T40(A), T41(C), T49(B)
Stereo Component Amplifier Assembly

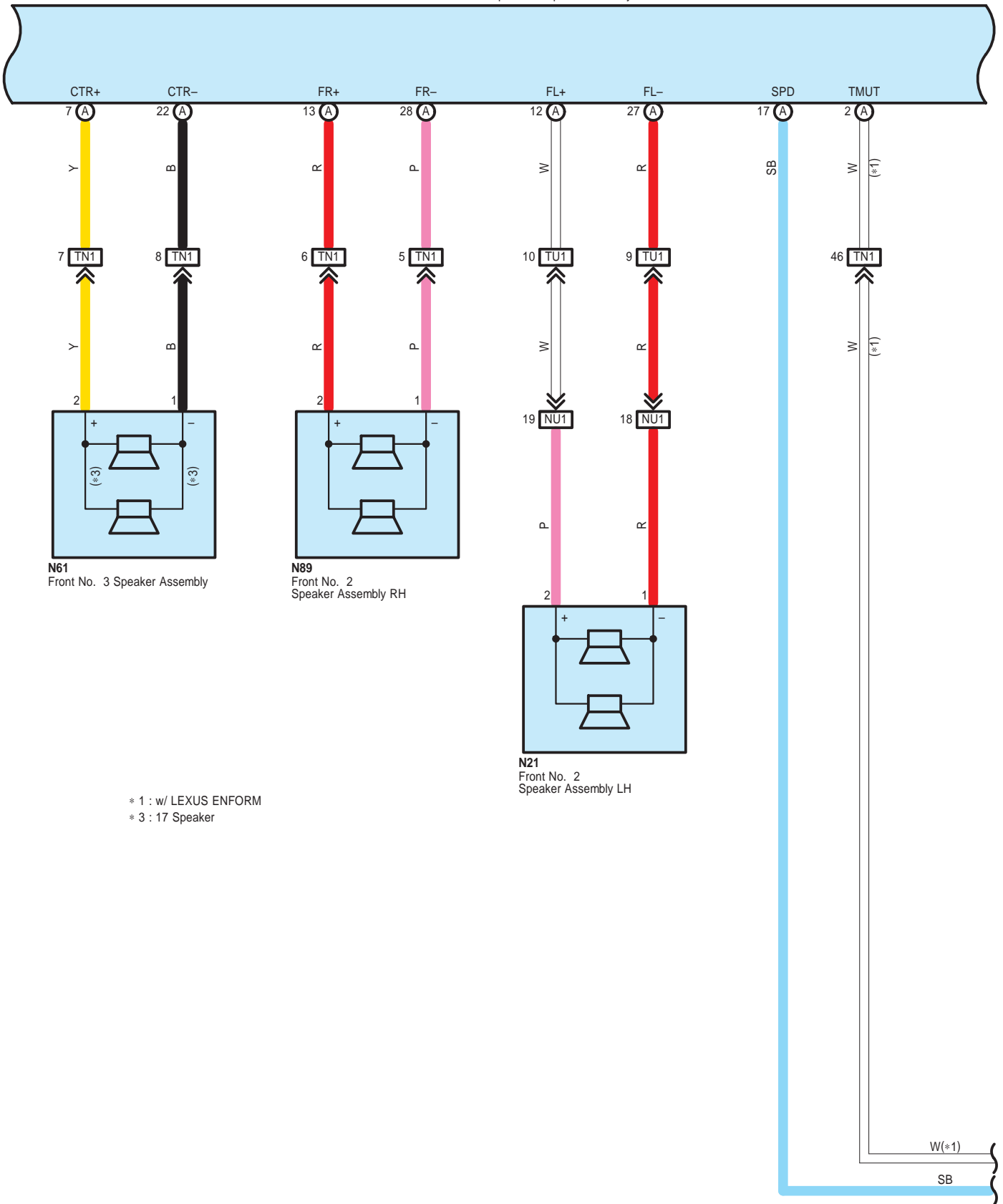

T40(A), T41(C), T49(B)
Stereo Component Amplifier Assembly

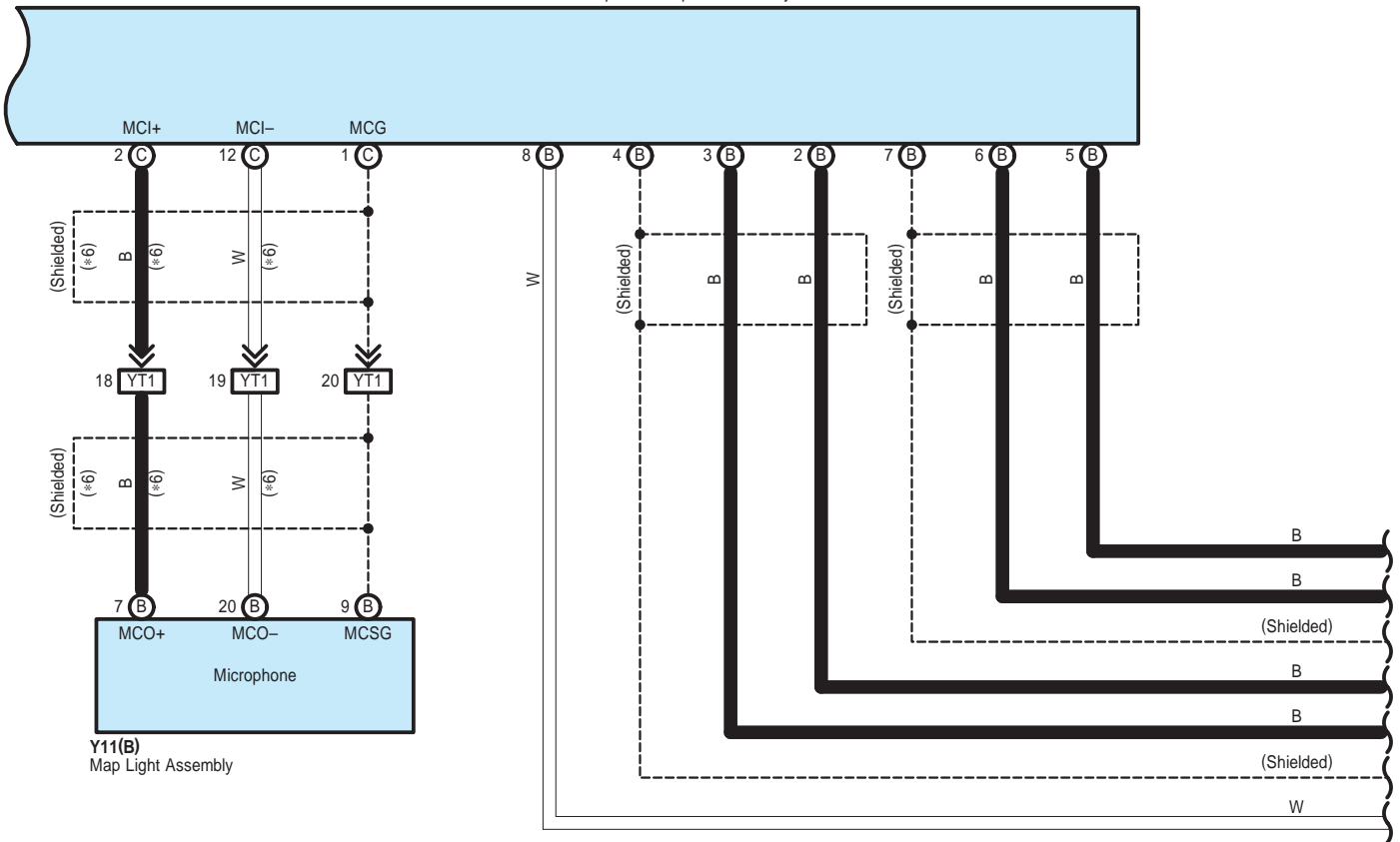

- * 1 : w/ LEXUS ENFORM
- * 6 : w/ LEXUS Navigation System

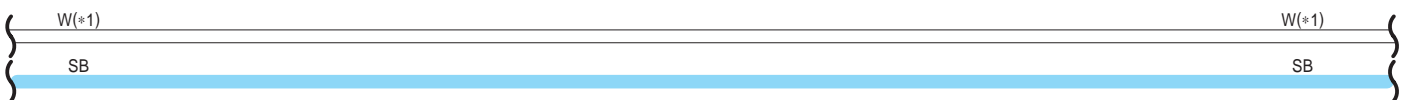

N66(A), N68(C), N69(D), N138(E), N143(J), N146(I), N148(G), N149(H)
 Multi-Media Module Receiver Assembly

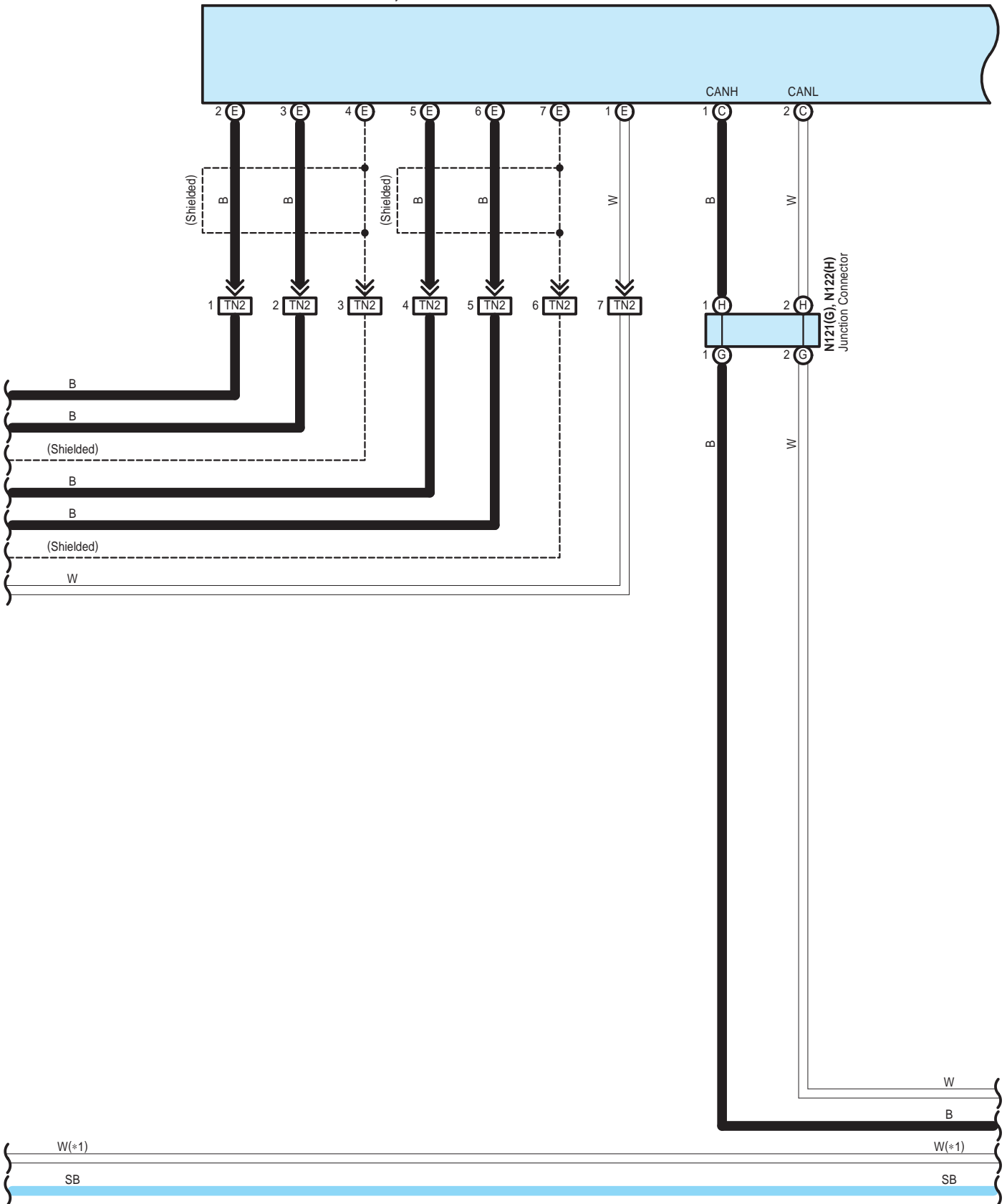

N66(A), N68(C), N69(D), N138(E), N143(J), N146(I), N148(G), N149(H)
Multi-Media Module Receiver Assembly

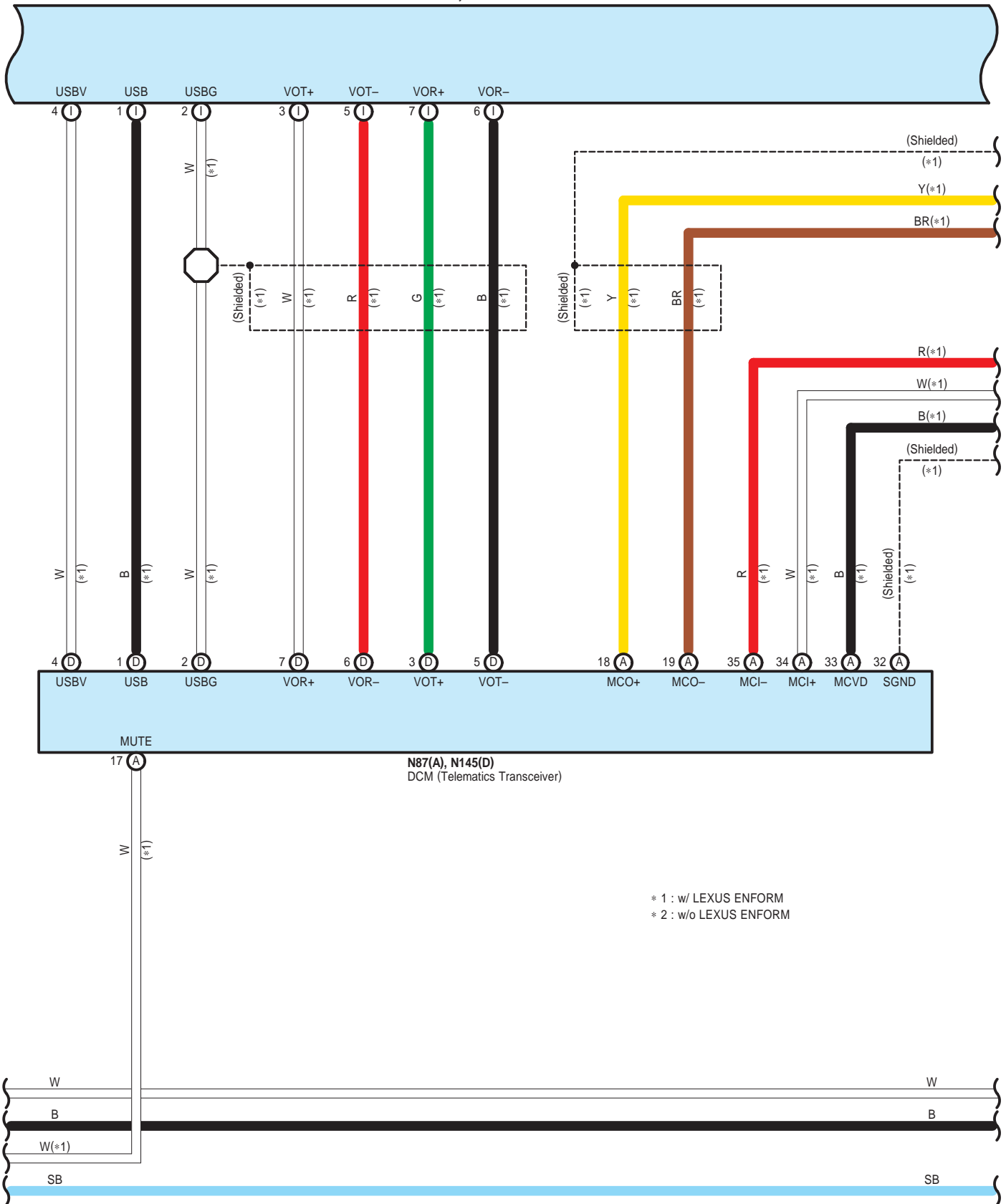

* 1 : w/ LEXUS ENFORM
* 2 : w/o LEXUS ENFORM

N66(A), N68(C), N69(D), N138(E), N143(J), N146(I), N148(G), N149(H)
Multi-Media Module Receiver Assembly

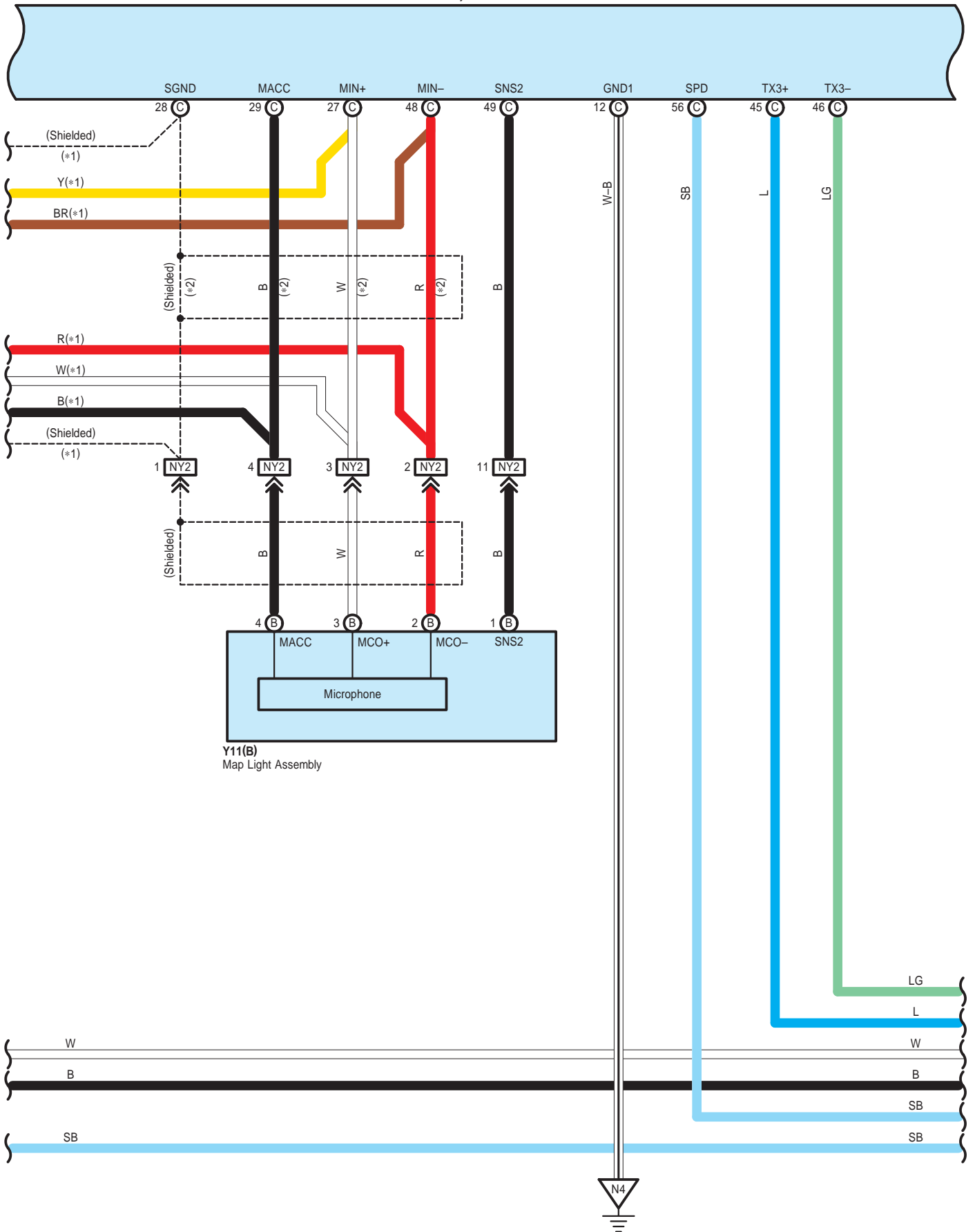

N66(A), N68(C), N69(D), N138(E), N143(J), N146(I), N148(G), N149(H)
Multi-Media Module Receiver Assembly

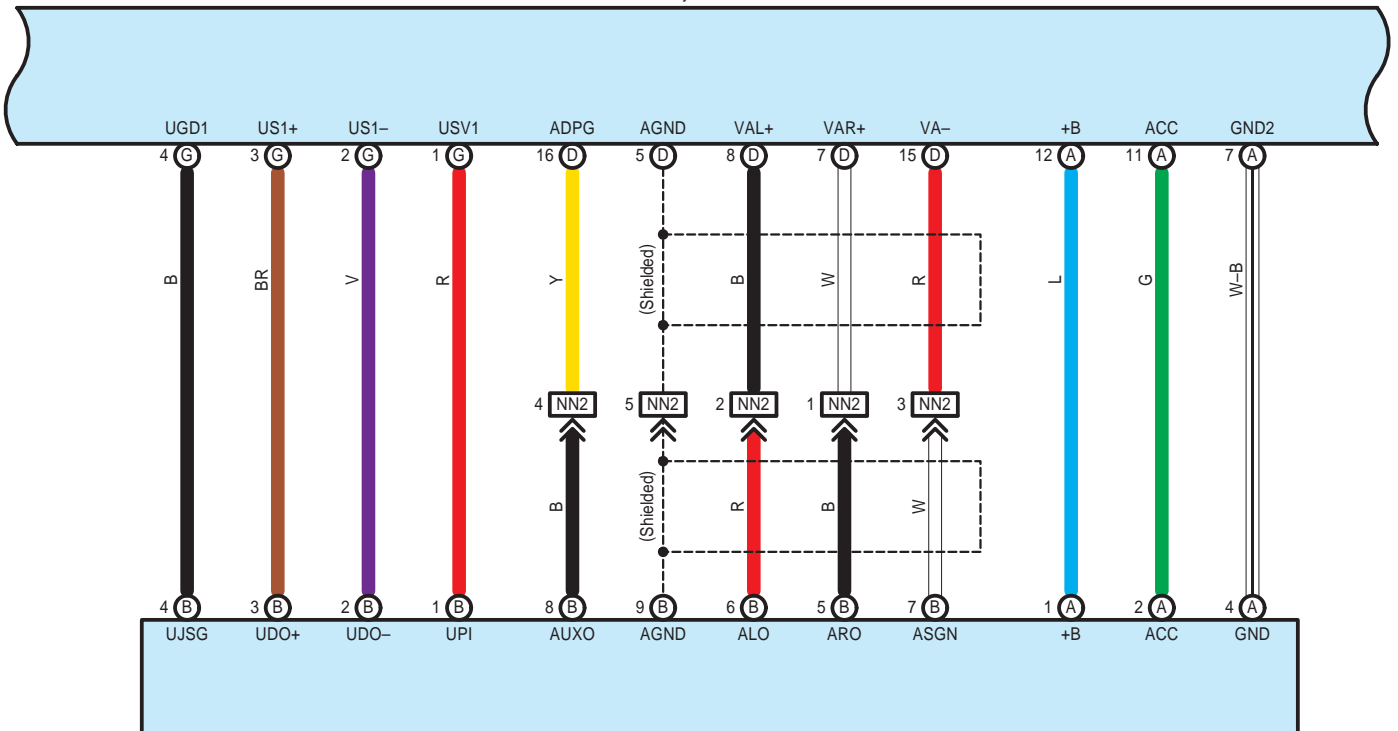

N54(A), N147(B)
Stereo Jack Adapter Assembly



N66(A), N68(C), N69(D), N138(E), N143(J), N146(I), N148(G), N149(H)
Multi-Media Module Receiver Assembly

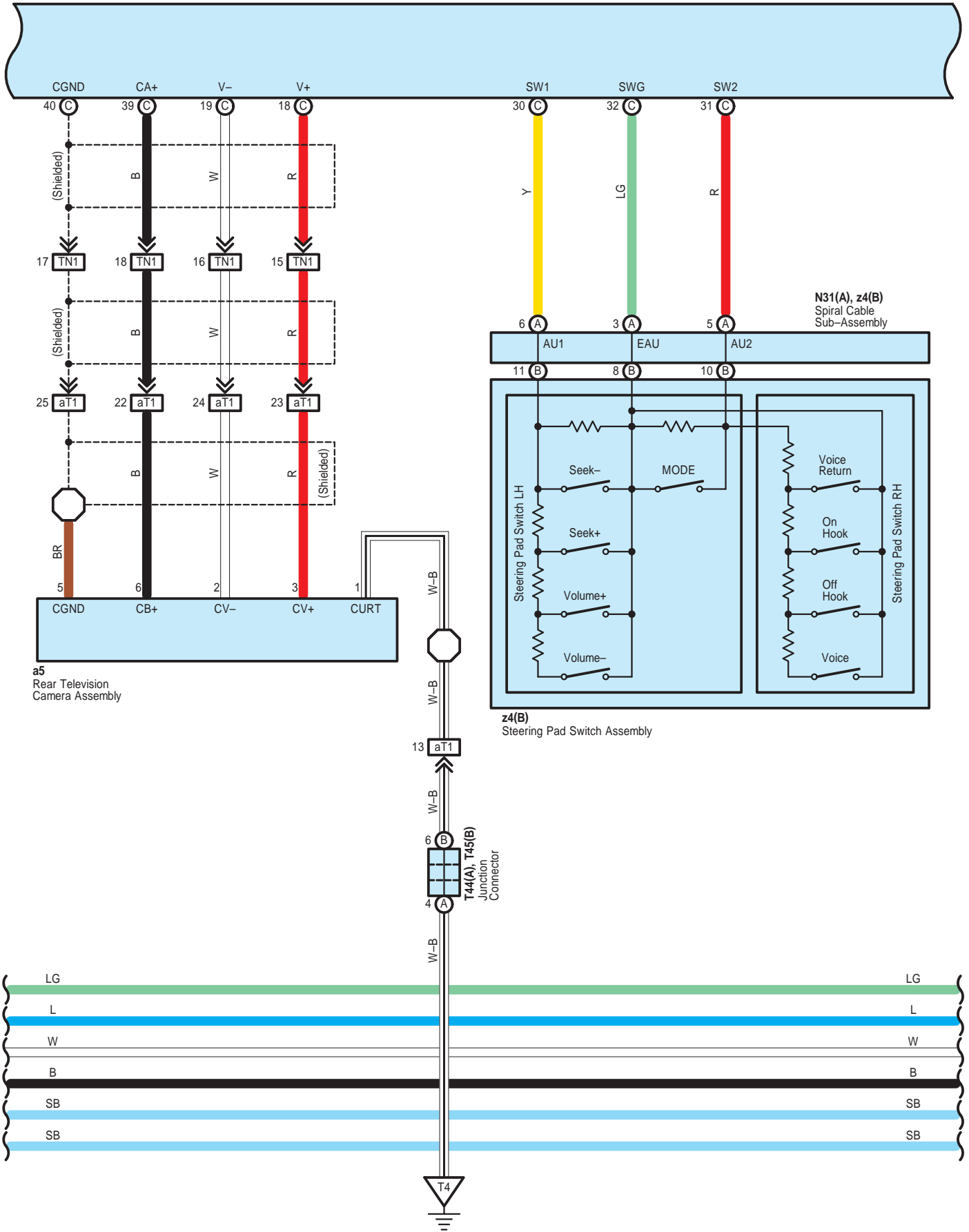

N66(A), N68(C), N69(D), N138(E), N143(J), N146(I), N148(G), N149(H)
Multi-Media Module Receiver Assembly

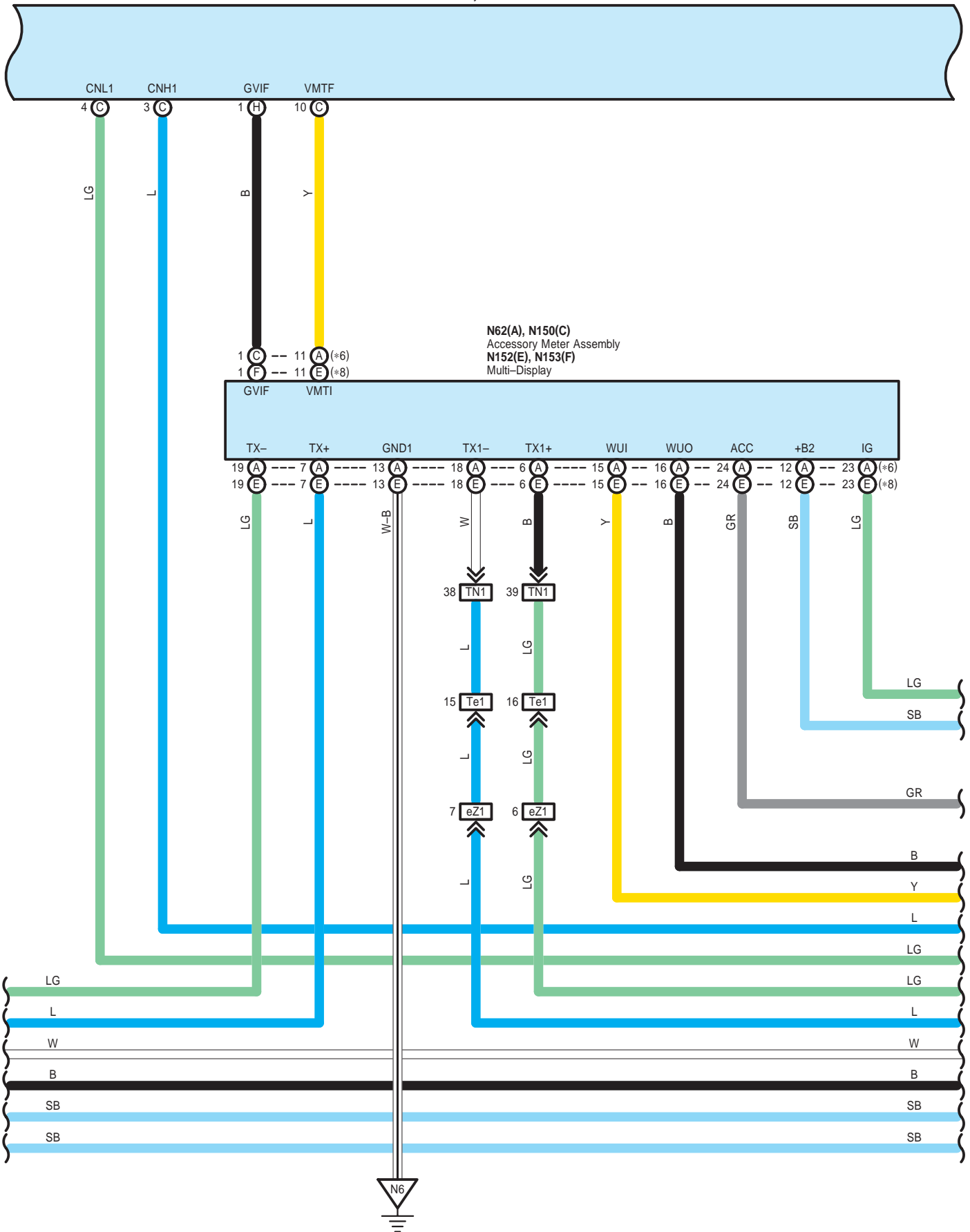

N66(A), N68(C), N69(D), N138(E), N143(J), N146(I), N148(G), N149(H)
Multi-Media Module Receiver Assembly

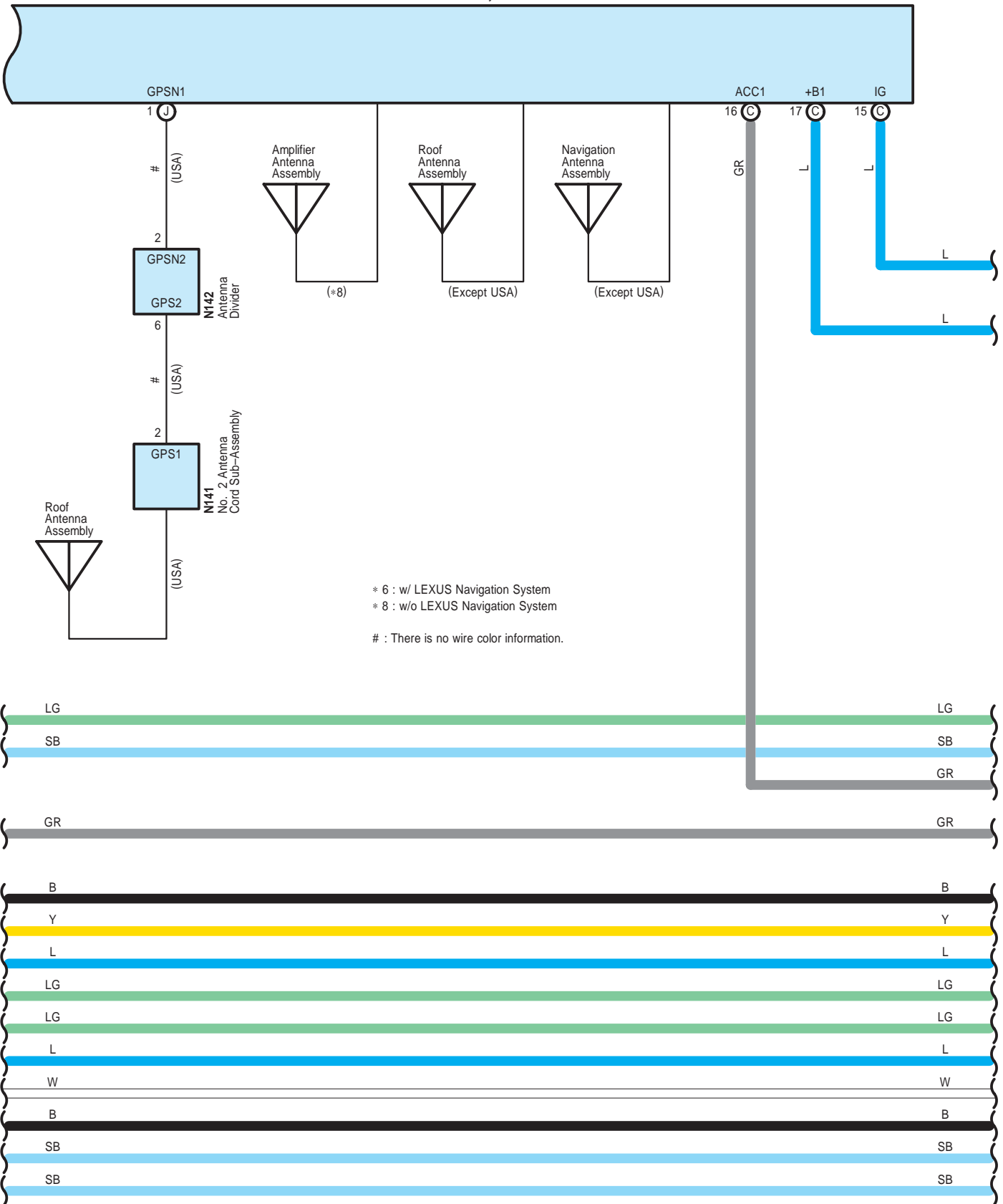

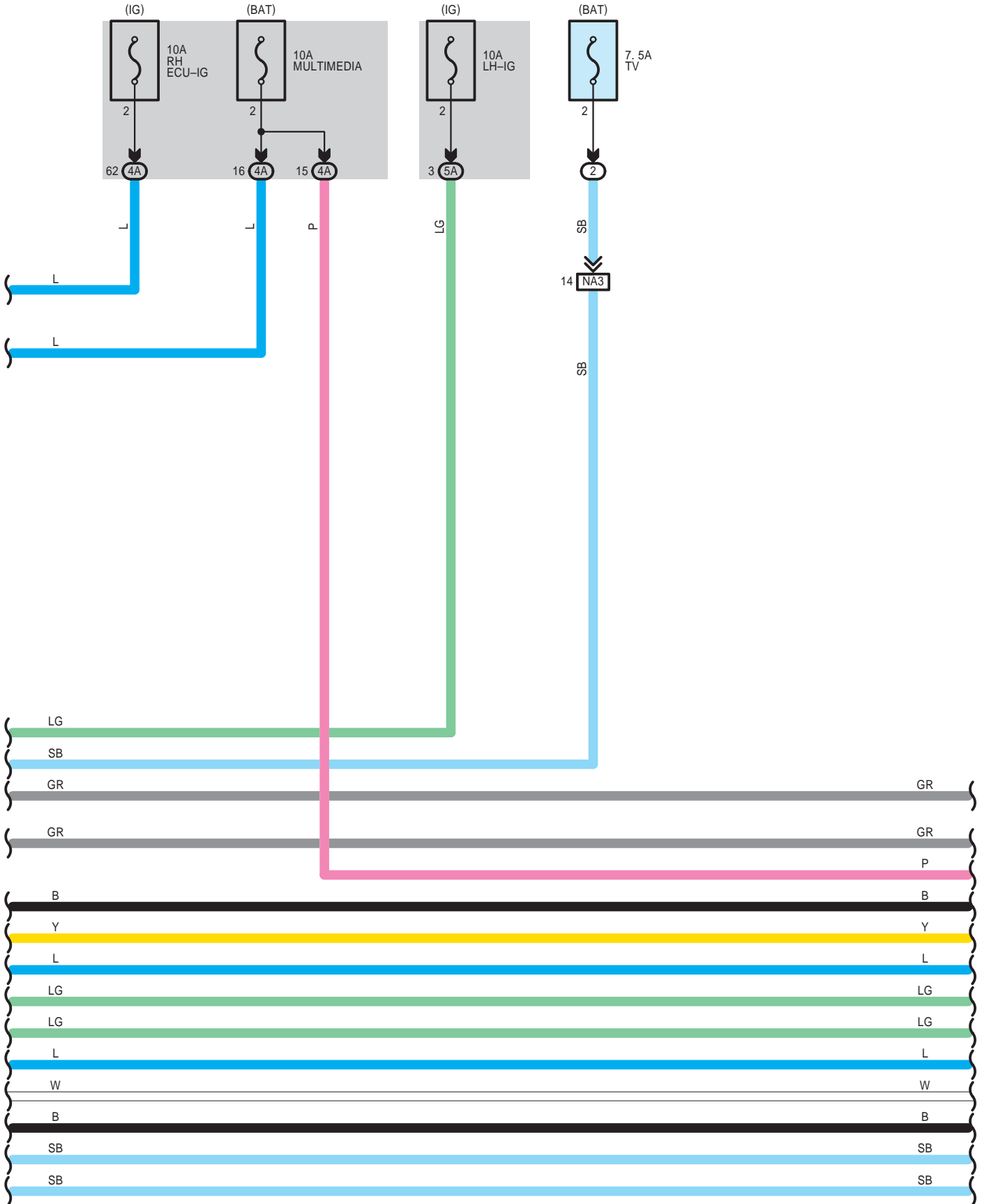

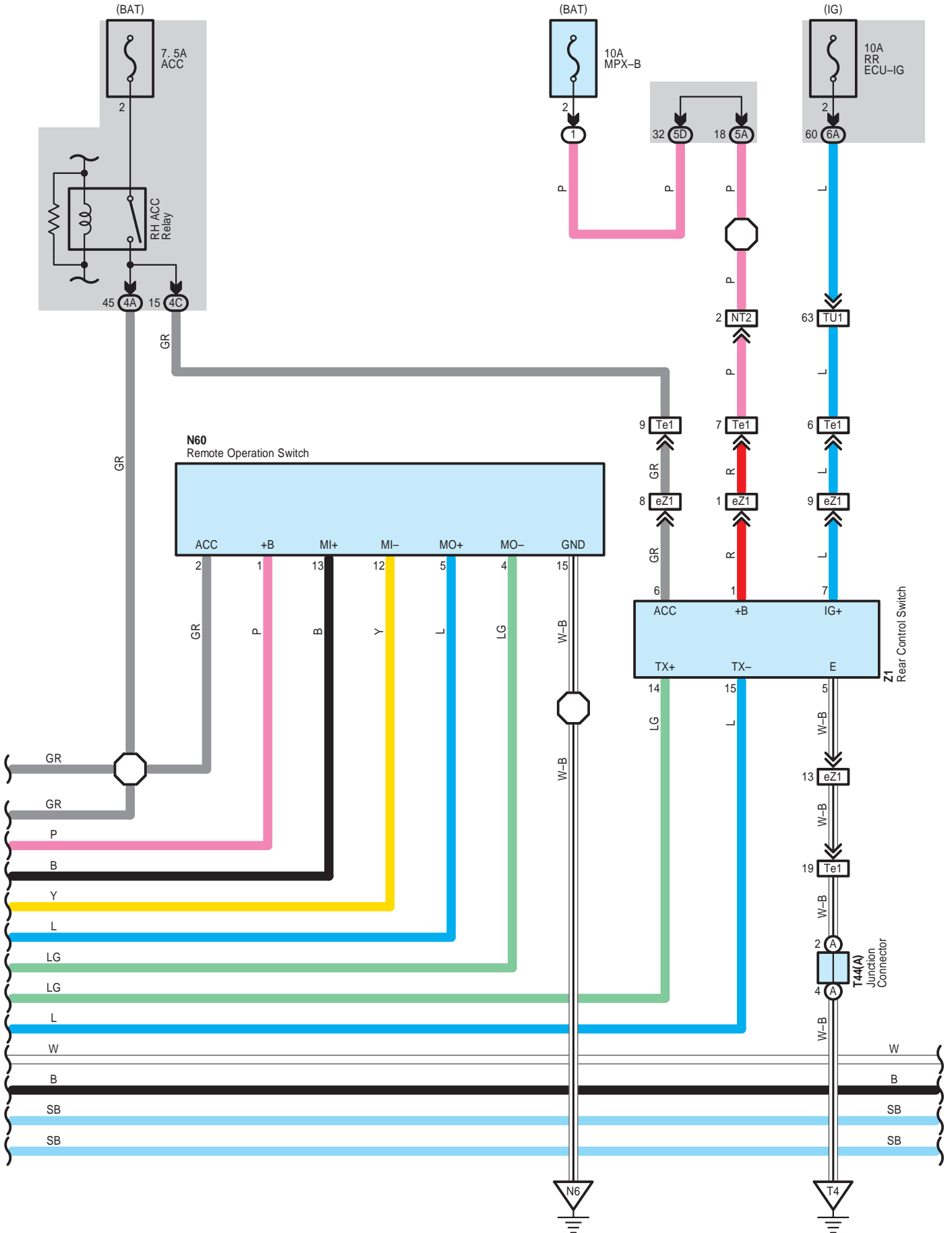

- * 4 : w/ VGRS
- * 5 : w/o VGRS
- * 7 : Parking Assist (Back Guide Monitor)

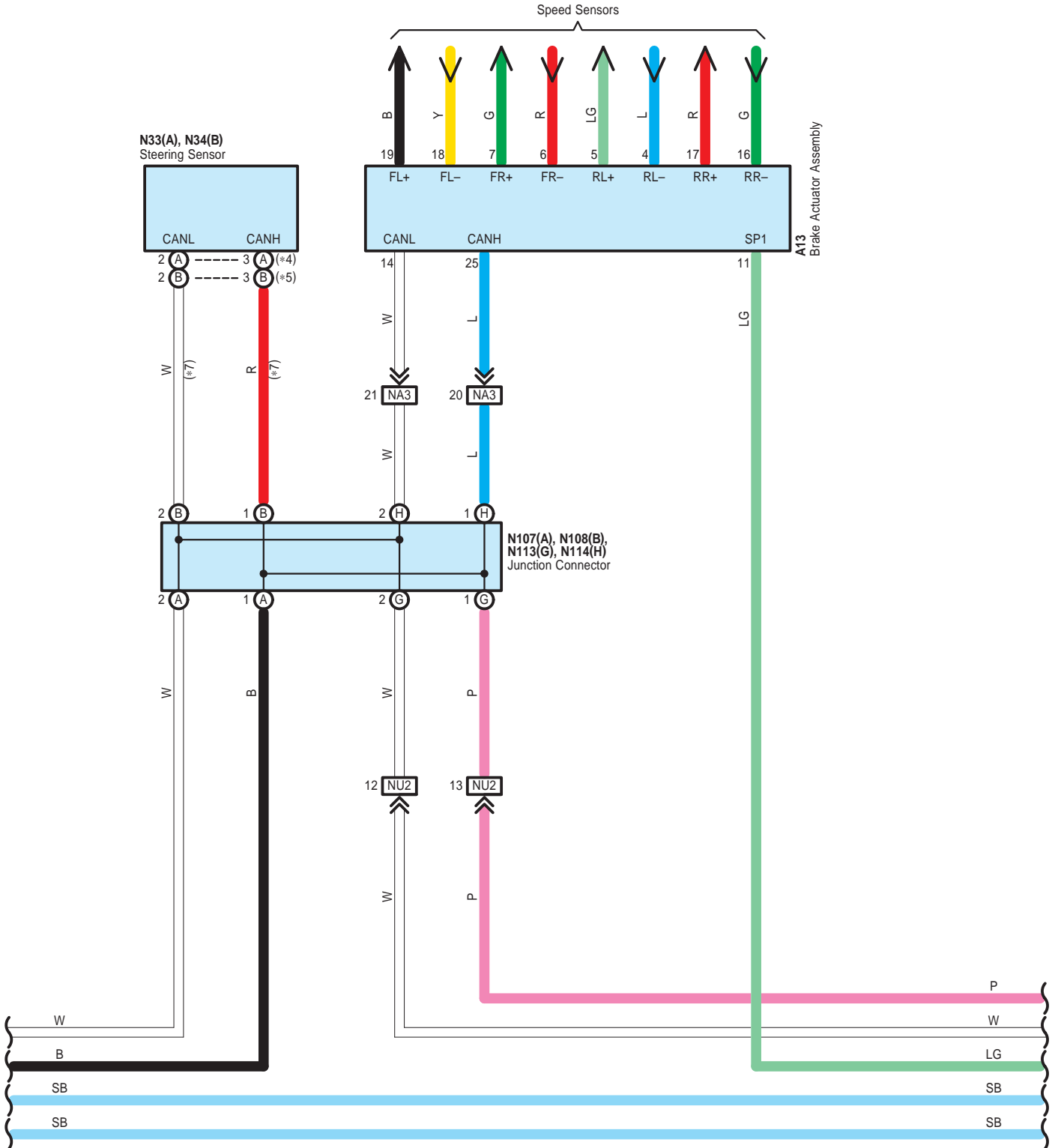

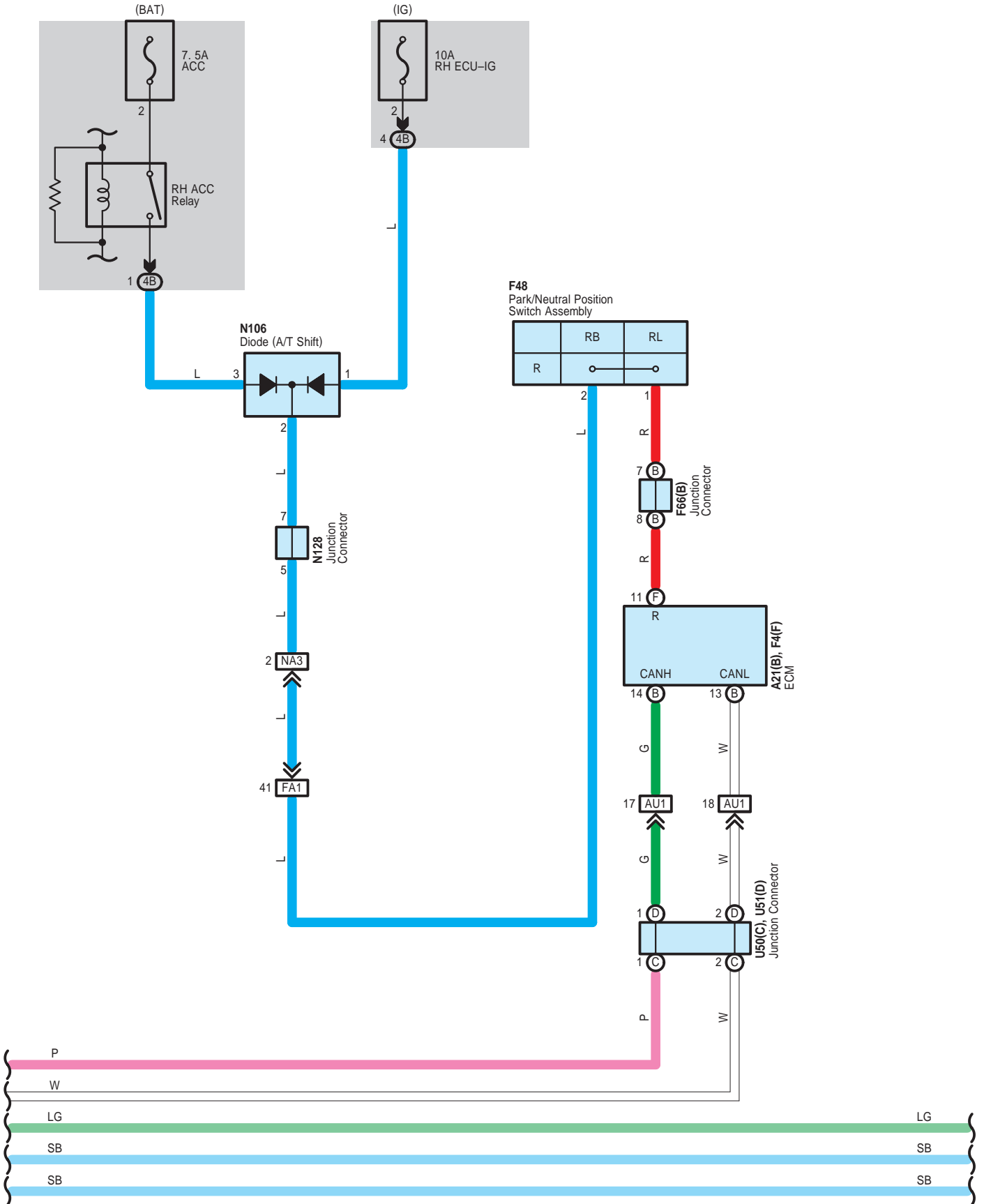

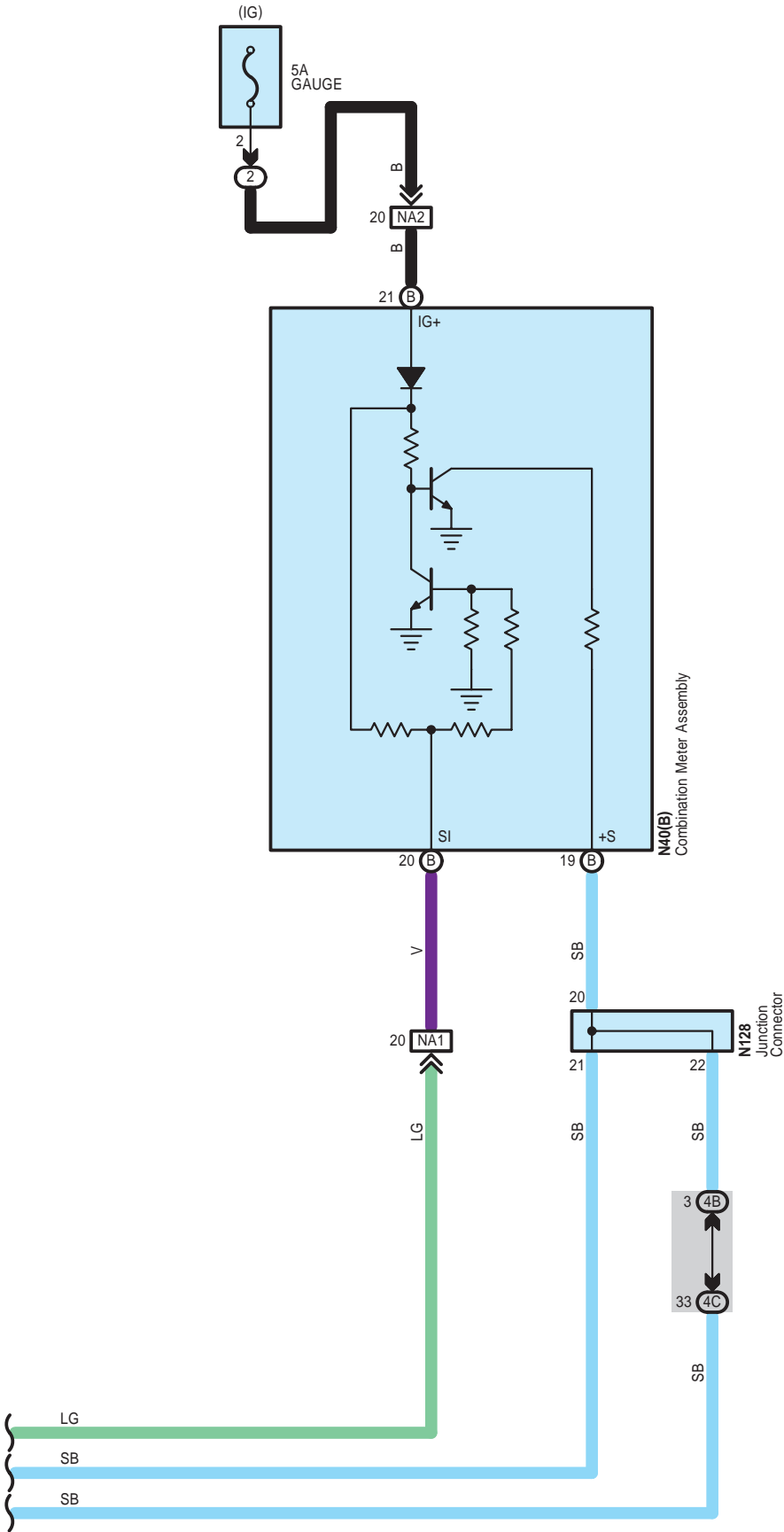

A 13
Black

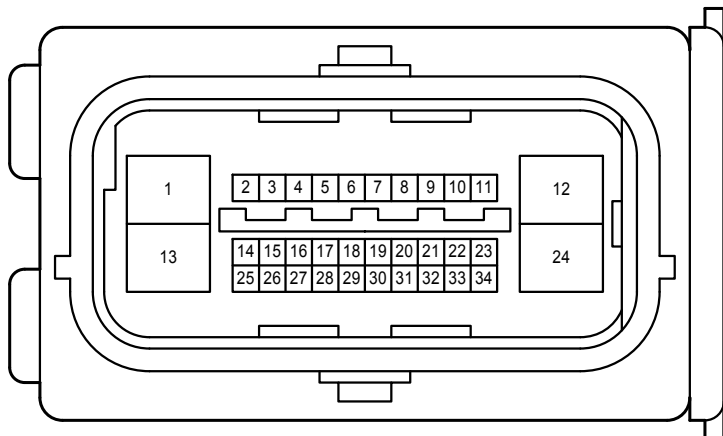

A 21
White

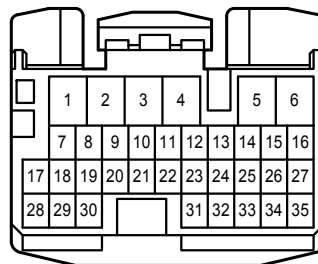

F 4
White

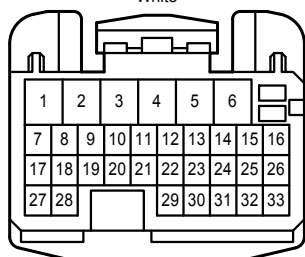

F 48
Black

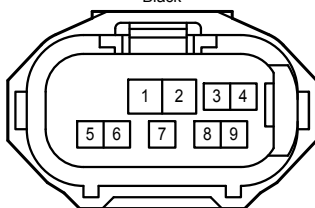

F 66
Gray

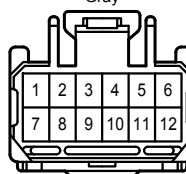

N 21
Black

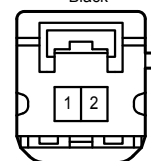

N 31
Black

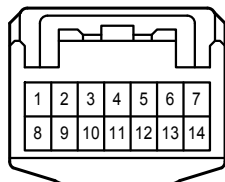

N 33
White

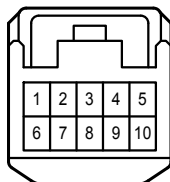

N 34
Black

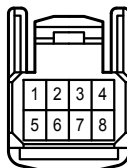

N 40
Black

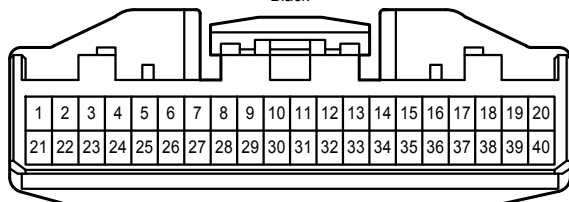

N 54
Gray

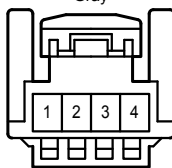

N 60
White

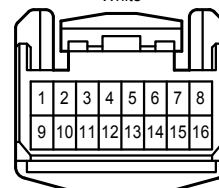

N 61
Black

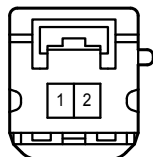

N 62
Black

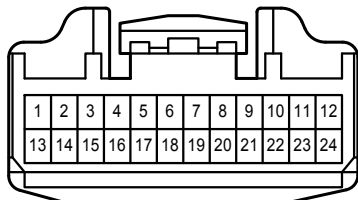

N 66
White

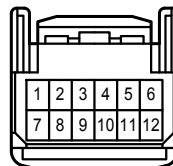

N152
Black

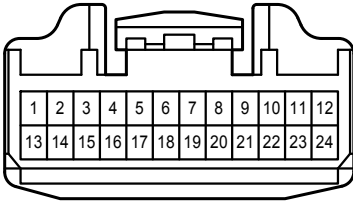

N153
Blue



Q 1
Black



Q 16
Black



R 4
White

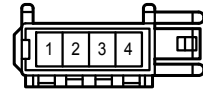

R 5
Black



R 12
White

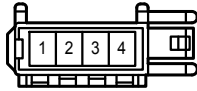

R 13
Black



T 24
Black



T 25
Black

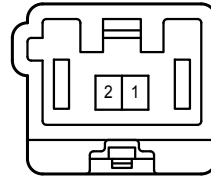

T 40
White

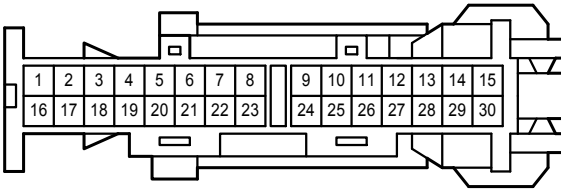

T 41
White

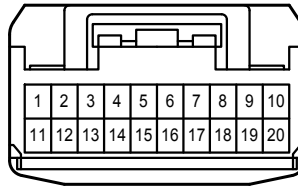

T 44
Blue

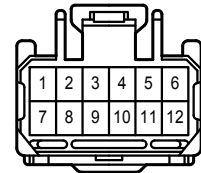

T 45
Blue

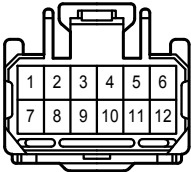

T 49
White

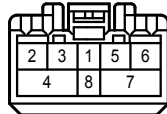

U 26
Black

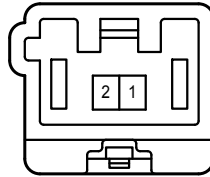

U 50
White

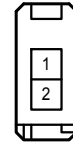

U 51
White

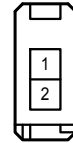

Y 11
White

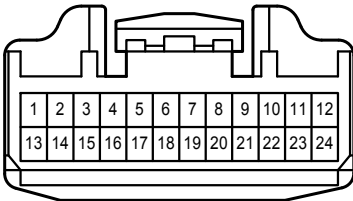

Z 1
White

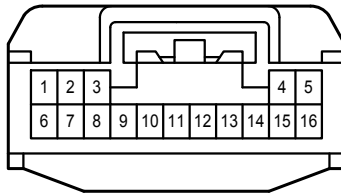

a 5
Gray

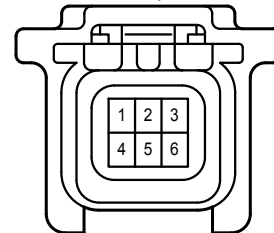

z 4
Black

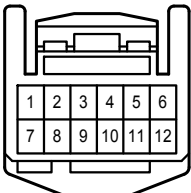

4A
White

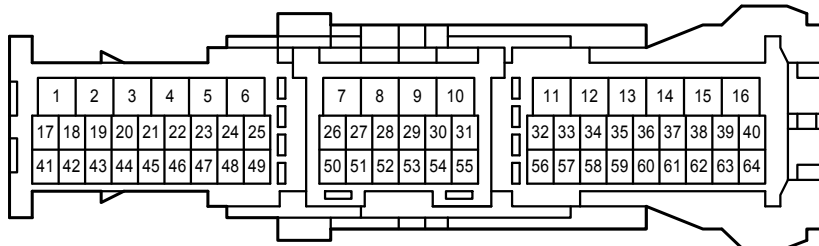

4B

White

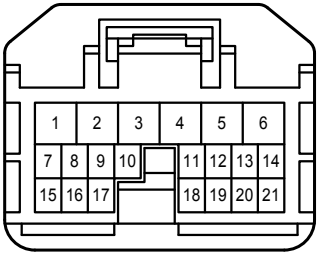

4C

White

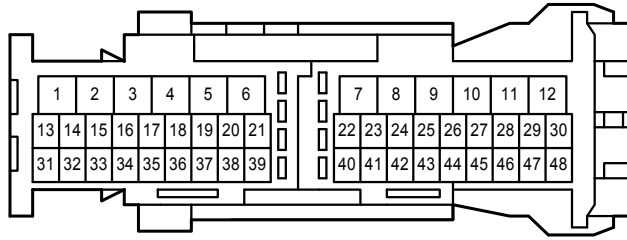

5A

White

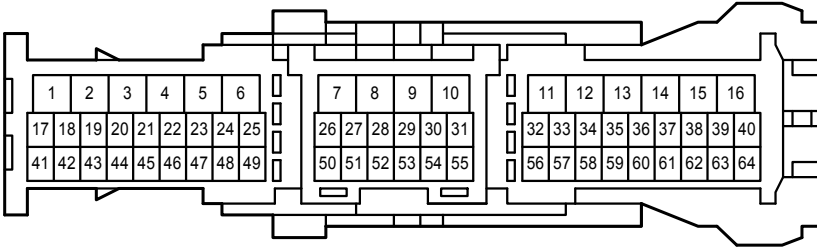

5D

White

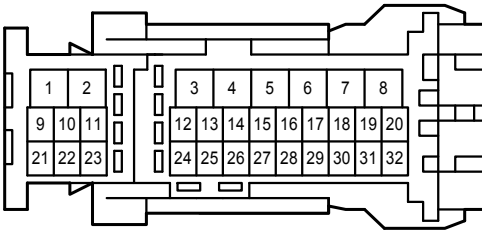

6A

White

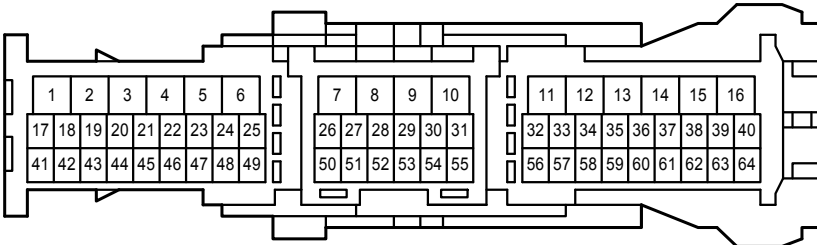

AU1

White

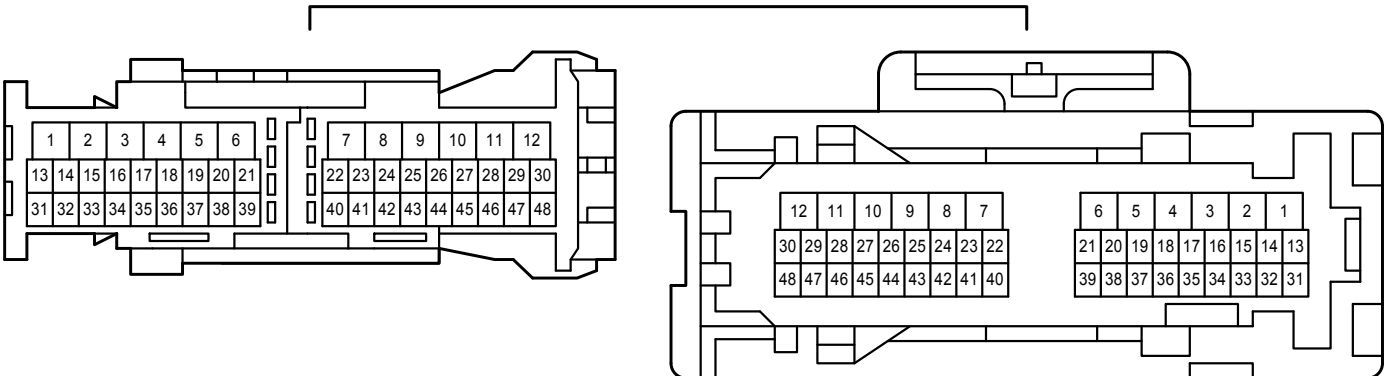

FA1
White

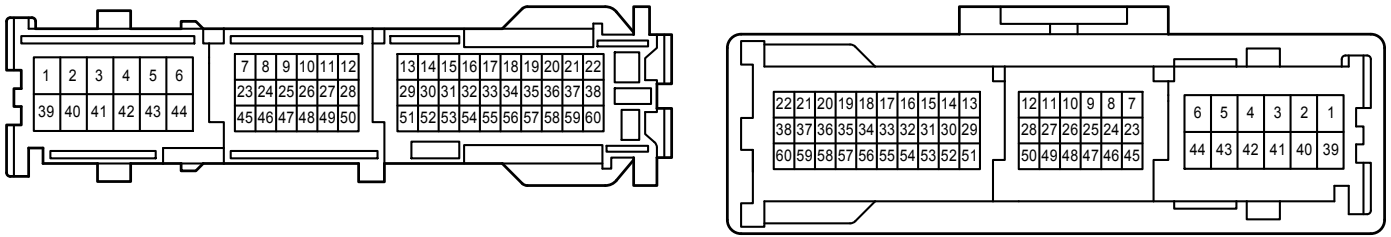

NA1
White

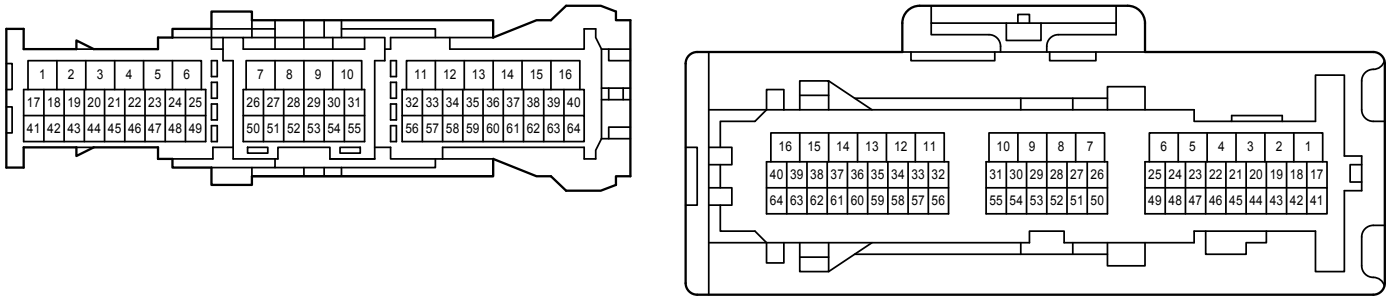

NA2
White

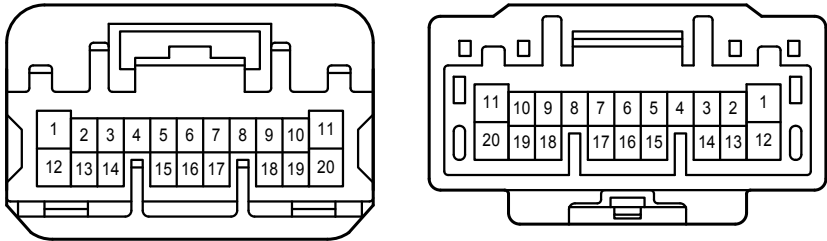

NA3
White

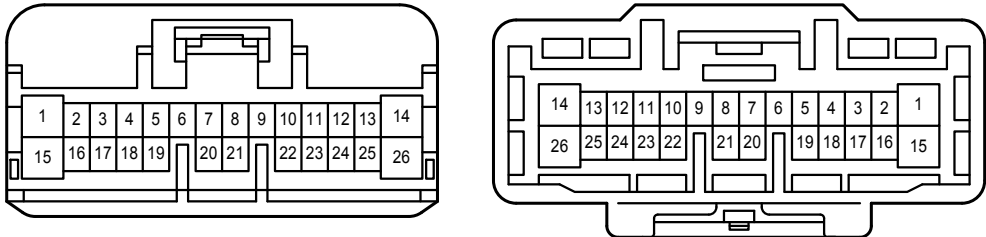

NN2
White

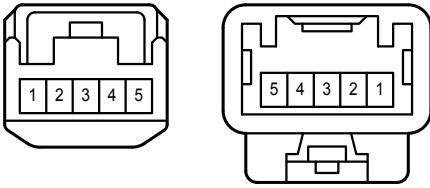

NT2
White

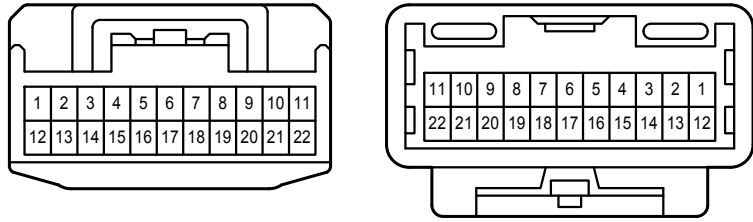

NU1
White

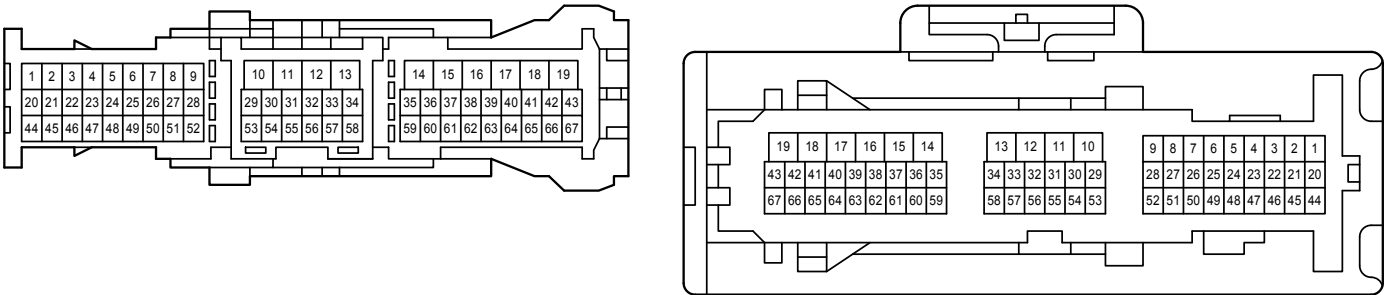

NU2
White

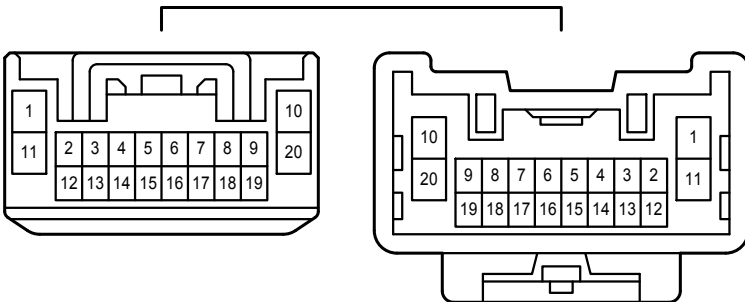

NY2
White

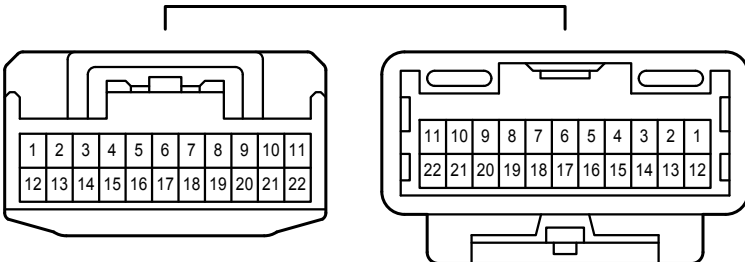

QT1
White

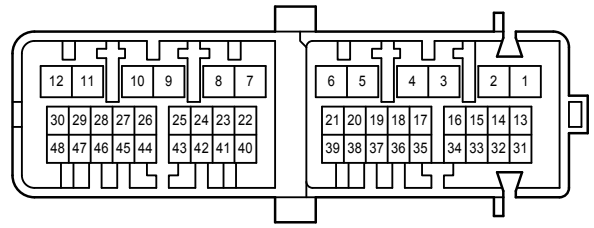
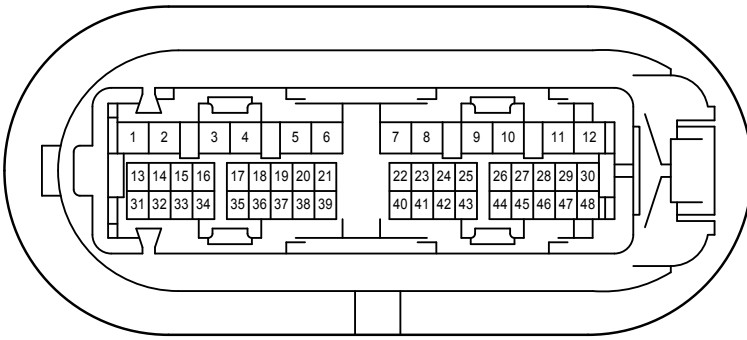

QU1
White

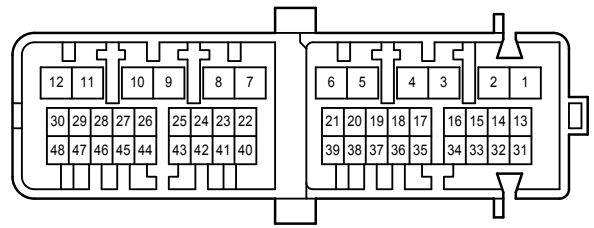
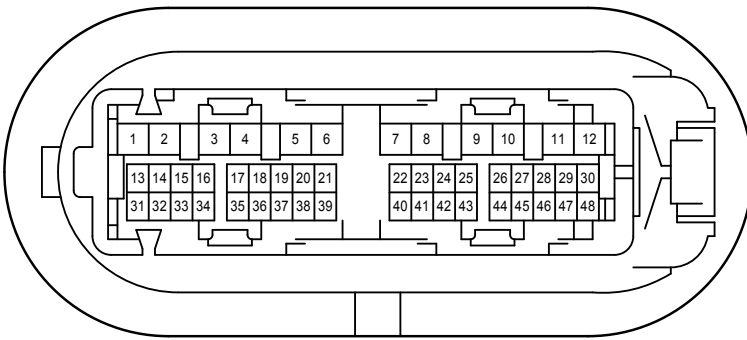

RT1
White

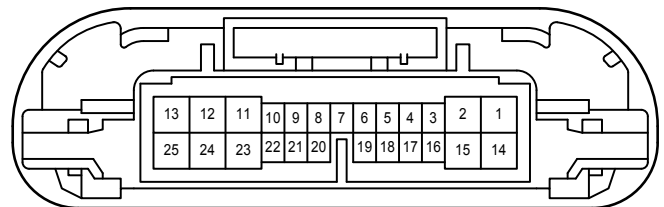
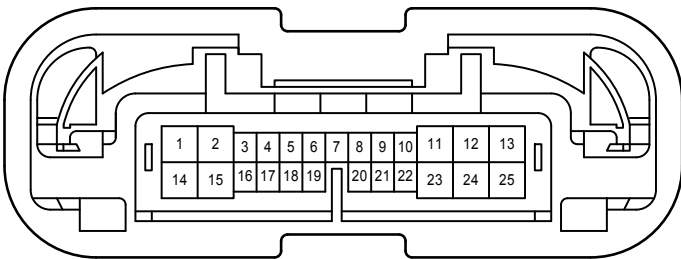

RU1
White

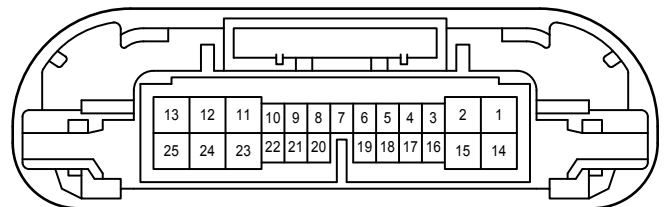
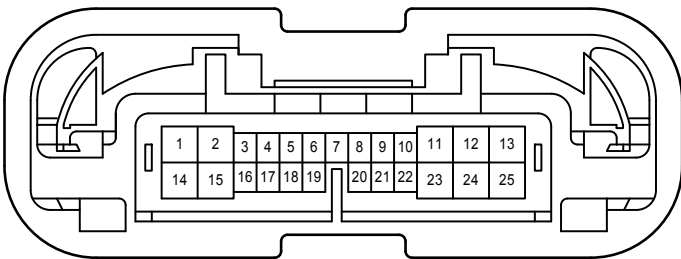

TN1
White

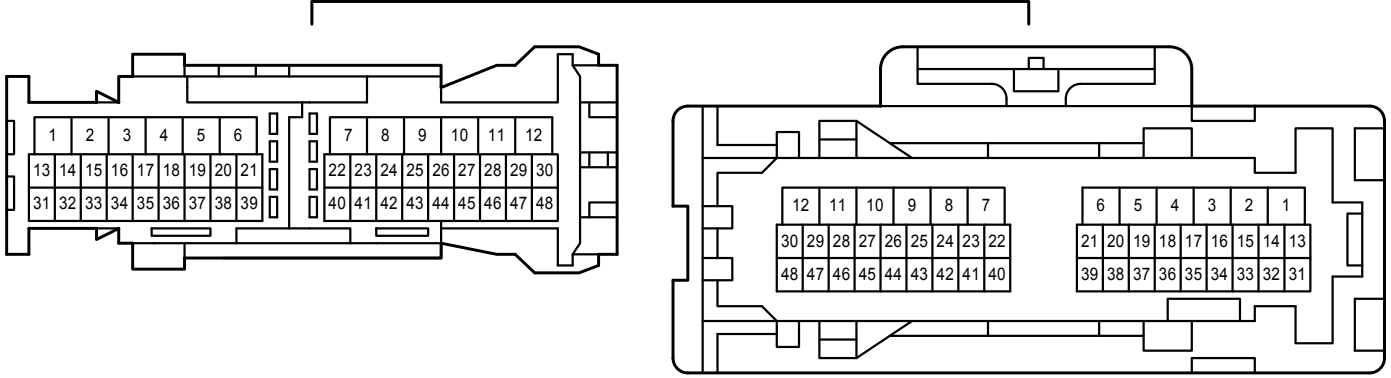

TN2
Gray

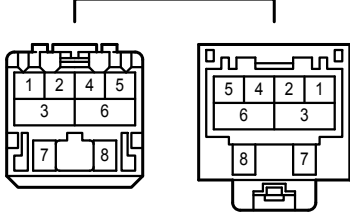

TU1
White

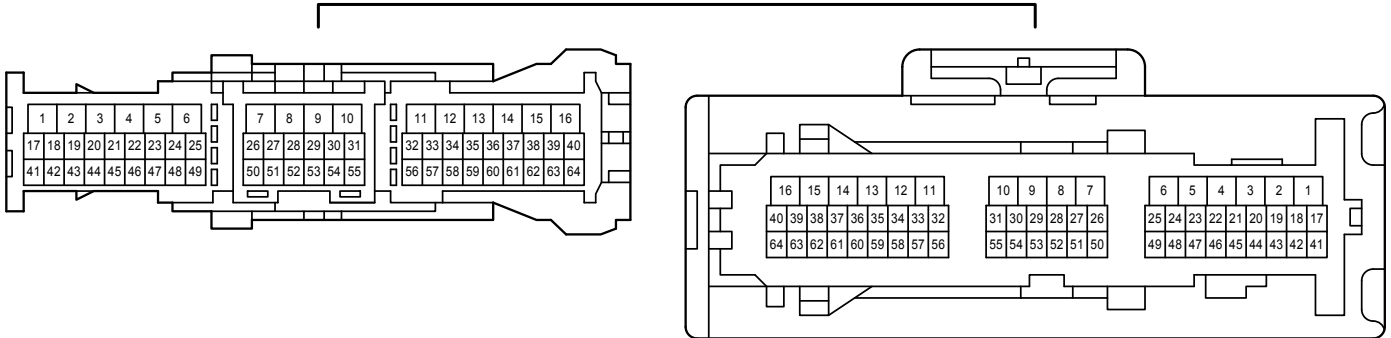

Te1
White

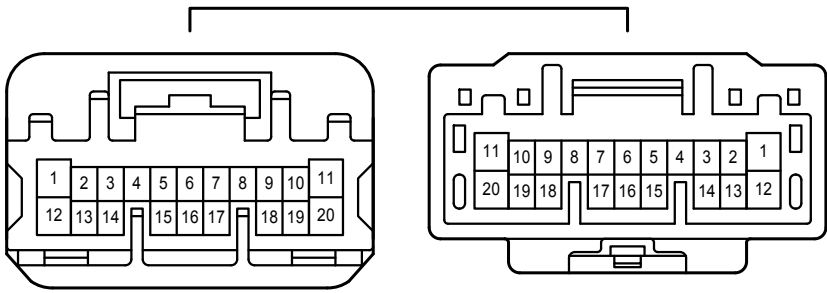

UT1
White

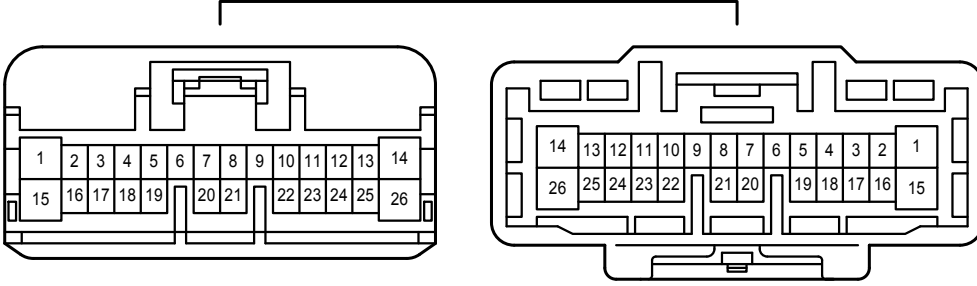

YT1
White

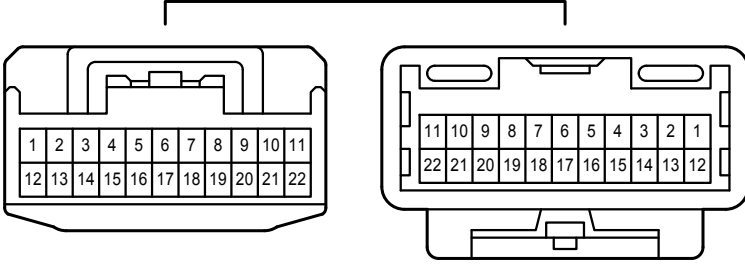

aT1
White

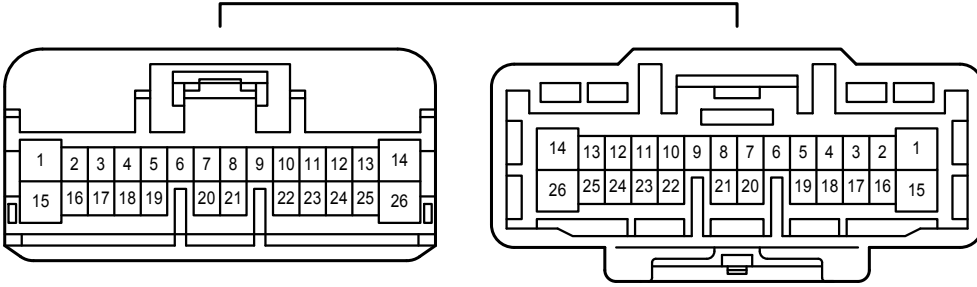

eZ1
White

