

**Part Number: PT545-00082**

**Kit Contents**

Item #	Quantity Reqd.	Description
1	1	Unit Assembly Kit
2	1	Mounting Kit
3	1	Hardware Bags
4	1	Unit and Fit Kit List

**Unit Assembly Kit Contents**

Item #	Quantity Reqd.	Description
1	1	Interface Kit

**Mounting Kit Contents**

Item #	Quantity Reqd.	Description
1	1	iPod Cable
2	1	Grommet

**Hardware Bag Contents**

Item #	Quantity Reqd.	Description
1	1	Foam Sleeve
2	4	2x4 inch Adhesive Protective Foam
3	4	14 inch Lock Tie
4	2	6 inch Lock Tie

**Conflicts**

<b>XM or Sirius Satellite Radio</b>
-------------------------------------

**Recommended Tools**

<b>Personal &amp; Vehicle Protection</b>	<b>Notes</b>
Safety Goggles	
Seat Covers	
<b>Special Tools</b>	
iPOD Checker	IADS # AVA08-038-01
Panel Clip Removal	SST # 00002-06001-01
Sockets	10 mm, 8 mm
Screwdriver	Phillips, #2
Torque Wrench	4.1N M (36lbf in) (battery cable) 10N M (7ft-lbf) Knee Air Bag bolts
Hole Saw	1 1/8 inch (29 mm)
<b>Installation Tools</b>	Notes
Tape Measure	Metric/Standard
Side Cutters	
Protective Tape	

<b>Special Chemicals</b>	<b>Notes</b>
Cleaner	Approved Cleaner or house hold glass cleaner

**NOTE:** Part number of this accessory may not be the same as the part number shown.

**General Applicability**

Note:-
--------

**Recommended Sequence of Application**





Item #	Accessory
1	Security System
2	RES
3	EC Rearview Mirror
4	Satellite Radio

\*Mandatory

**Vehicle Service Parts** (may be required for reassembly)

Item #	Quantity Reqd.	Description
1		
2		
3		

**Legend**

	<b>STOP:</b> Damage to the vehicle may occur. Do not proceed until process has been complied with.
	<b>OPERATOR SAFETY:</b> Use caution to avoid risk of injury.
	<b>CAUTION:</b> A process that must be carefully observed in order to reduce the risk of damage to the accessory/vehicle and to ensure a quality installation.
	<b>TOOLS &amp; EQUIPMENT:</b> Used in Figures calls out the specific tools and equipment recommended for this process.
	<b>REVISION MARK:</b> This mark highlights a change in installation with respect to previous issue.

Parts Description of Interface Kit Assy

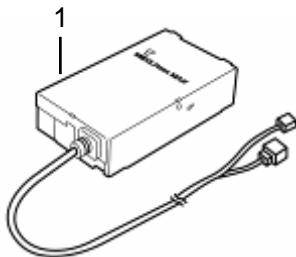

Item #	PartsName	PartsNo.	Qty
<b>1</b>	<b>Interface Kit</b>	<b>PT545-00082</b>	<b>1</b>

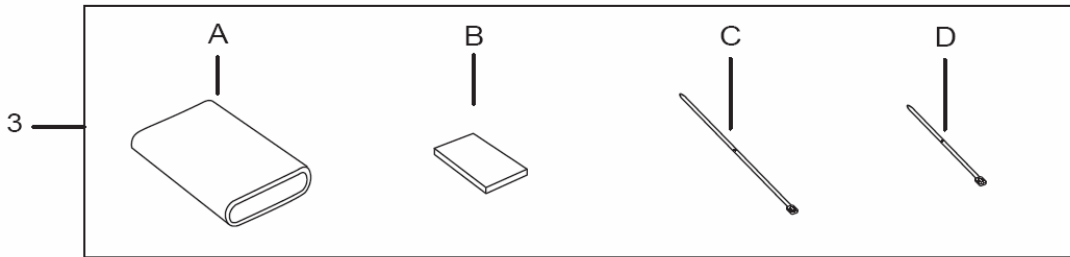
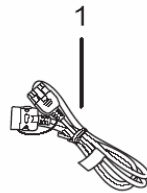

Parts Description of Mounting Kit (PT545-00082)

Item #	Parts Name	Qty
1	iPod Cable	1
2	Grommet	1
3	A Foam Sleeve	1
	B 2x4 inch Adhesive Protective Foam	4
	C 14 inch (16 inch) Lock Tie	4
	D 6 inch Lock Tie	2

Care must be taken when installing this accessory to ensure damage does not occur to the vehicle. The installation of this accessory should follow approved guidelines to ensure a quality installation.

These guidelines can be found in the "Accessory Installation Practices" document.

This document covers such items as:-

- Vehicle Protection (use of covers and blankets, cleaning chemicals, etc.).
- Safety (eye protection, rechecking torque procedure, etc.).
- Vehicle Disassembly/Reassembly (panel removal, part storage, etc.).
- Electrical Component Disassembly/Reassembly (battery disconnection, connector removal, etc.).

Please see your Toyota dealer for a copy of this document.

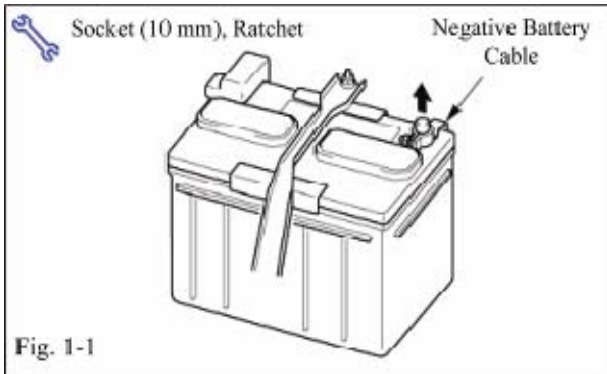

### 1. Remove the Negative (-) Battery Cable

- STOP (a) Set parking brake.
- (b) Remove the negative battery cable. (Fig. 1-1)
- STOP (1) Protect the fender before starting.
- +
- (2) Do not touch the positive terminal with any tool when removing cable.

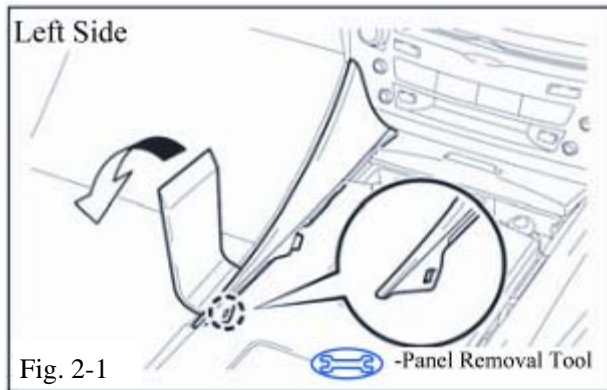

### 2. Vehicle Disassembly

- (a) Unscrew & remove the shift knob.

- (b) Remove upper console side trim – Auto Trans.



- (1) Using a nylon pry tool gently pry end upward to release clip as shown. (Figs. 2-1 & 2-2)

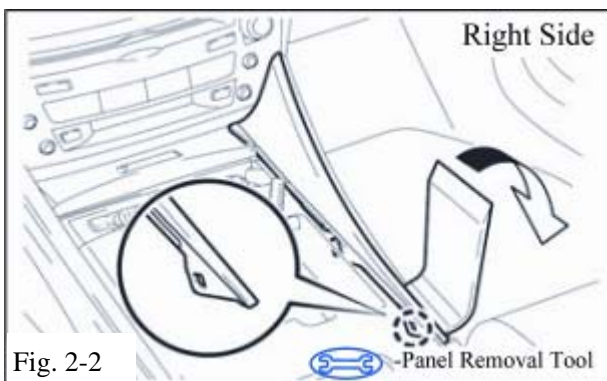

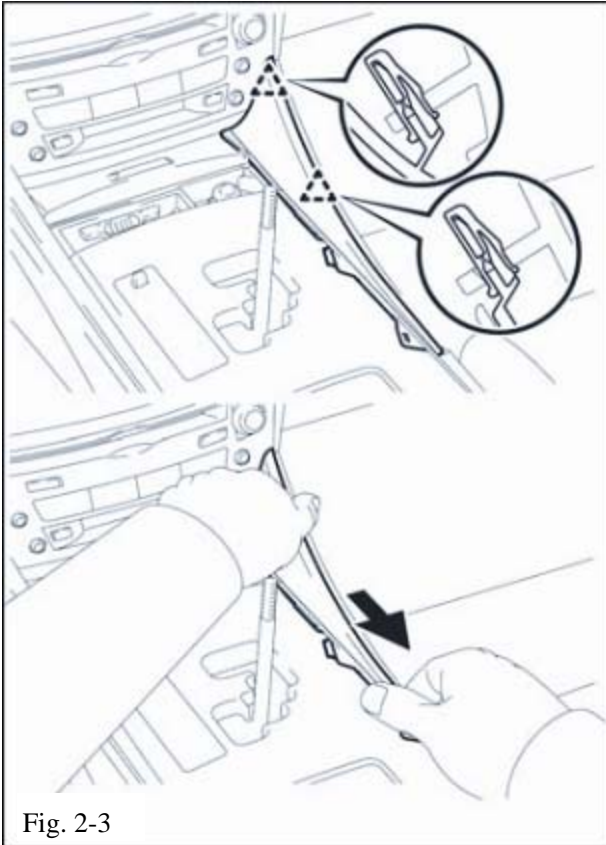

- (2) By hand gently pull upward and back to remove side trim. Remove both sides using same process. (Fig. 2-3 )

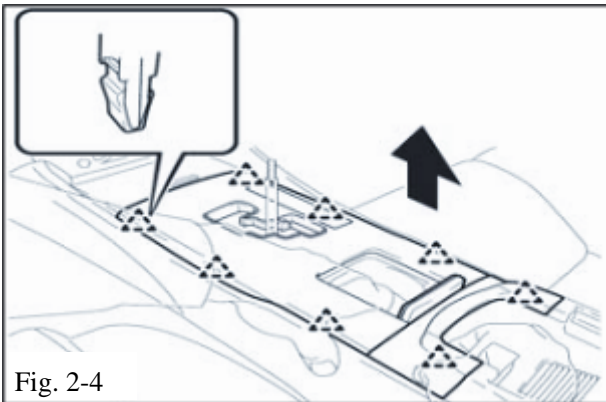

- (c) Remove the upper console trim – Auto Trans.
  - (1) By hand gently pull upward to release clips and remove the trim. (Fig. 2-4)
  - (2) Disconnect any connectors.

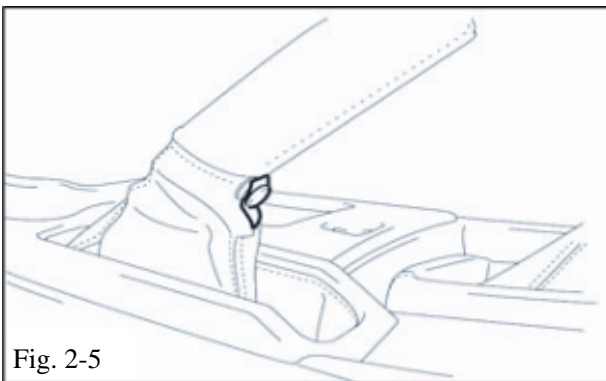

- (d) Remove the upper console trim – Manual Trans.
  - (1) Release snap on emergency brake leather cover. (Fig. 2-5)

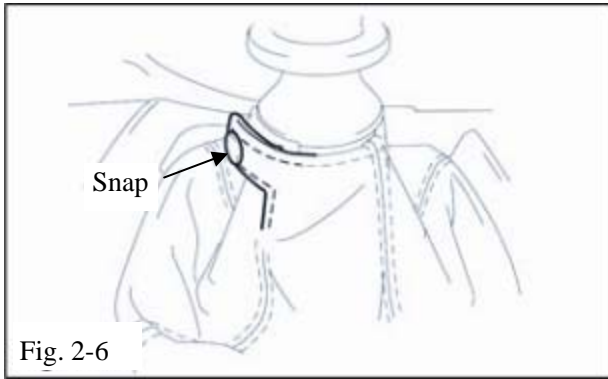

- (2) Release snap on shift lever cover. (Fig. 2-6)

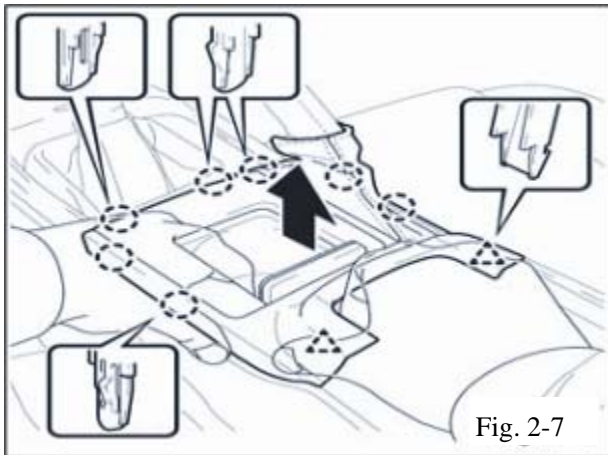

- (3) By hand grasp structure under cover and gently pull up on emergency brake leather cover assembly to release the clips & remove the cover. (Fig. 2-7)

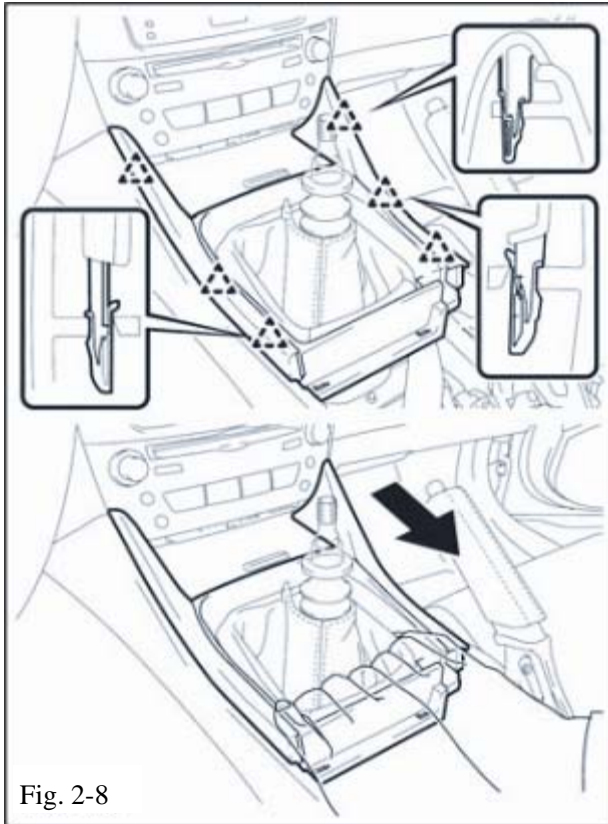

- (4) By hand gently pull up on shift lever leather cover to release clips & remove. (Fig. 2-8)





Fig. 2-9

- (e) Remove the center console upper box.
  - (1) Remove 2 screws as shown. (Fig. 2-9)

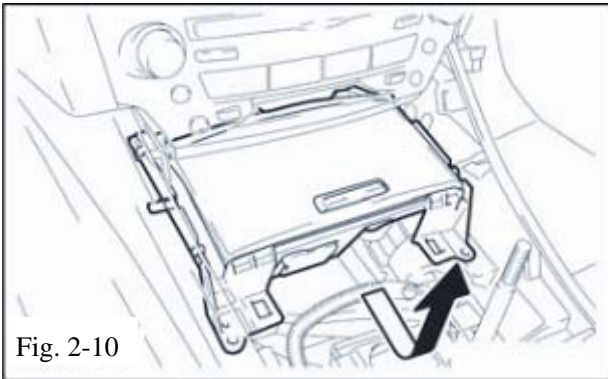

Fig. 2-10

- (2) By hand pull upward & remove box. (Fig. 2-10)
  - (3) Disconnect any connectors.

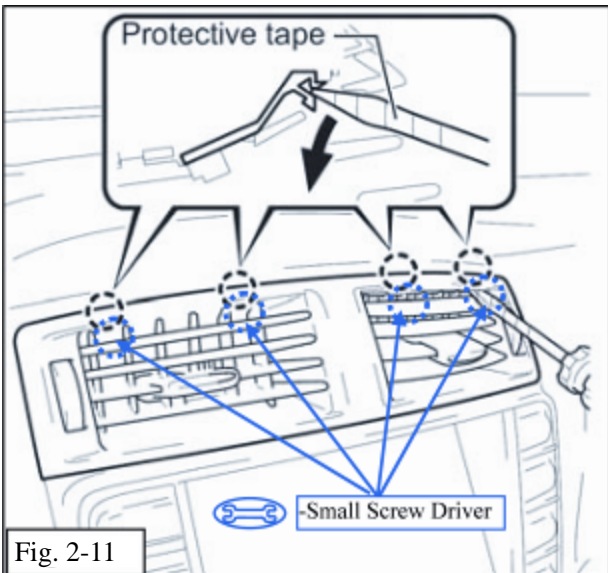



Fig. 2-11

- (f) Remove the upper vents trim piece. (Fig. 2-11)
  -  (1) Disengage the 4 clips using a screwdriver with protective tape applied as shown. (Fig. 2-11)

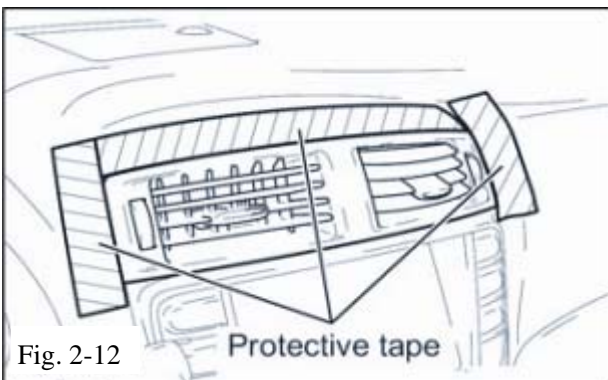
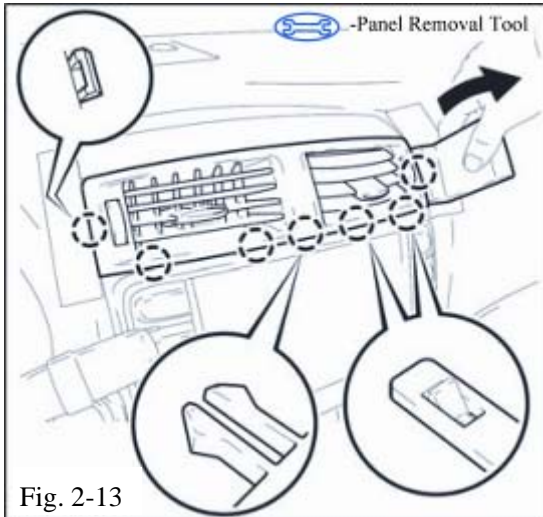
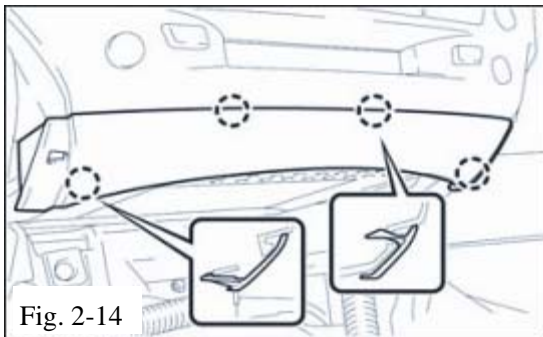

Fig. 2-12

- (2) Apply protective tape to dash area as shown. (Fig. 2-12)



- (3) Using a nylon pry tool gently pry on vent trim panel to release clips as shown. (Fig. 2-13)
- (4) Disconnect any connectors & then remove trim panel.



- (g) Remove the lower radio fascia.
  - (1) By hand gently pull outward to release the 4 clips to remove fascia. (Fig. 2-14)

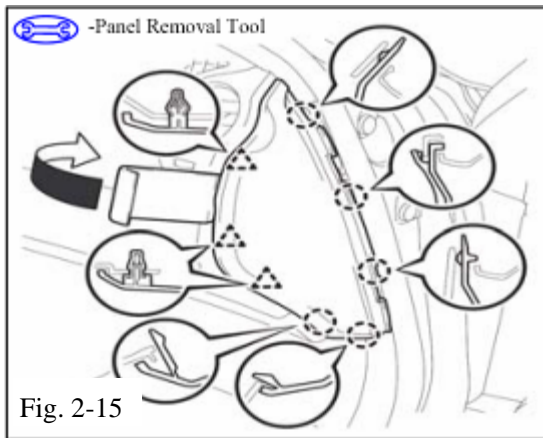

- (h) Remove "A" pillar dash panel.
  - (1) Using a nylon removal tool release the clips & claws as shown & remove the panel. (Fig 2-15)

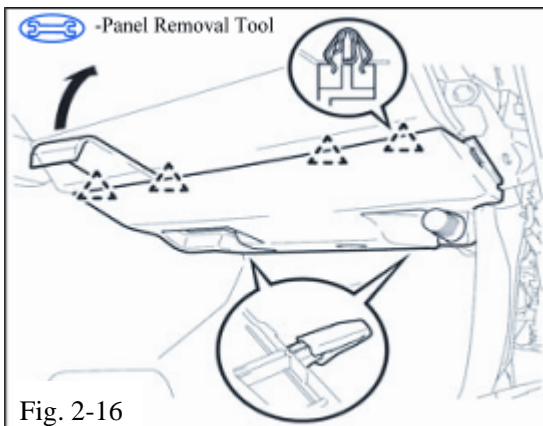

- (i) Remove the lower glove box trim panel.
  - (1) Using a nylon removal tool release the 4 clips as shown & remove the panel. (Fig. 2-16)
  - (2) Disconnect any connectors.

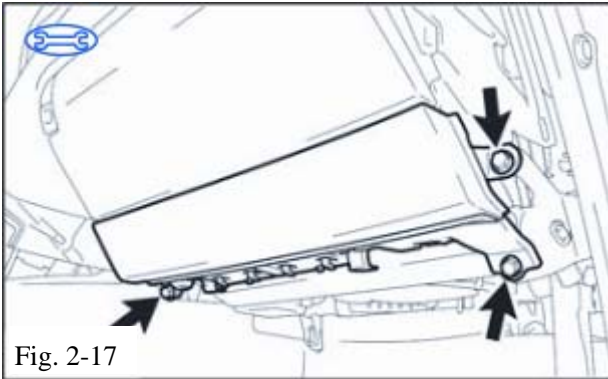

- (j) Remove Front Passenger Side Knee Airbag Assembly.
  - (1) Remove the 3 bolts and the airbag assembly. (Fig. 2-17) (Reassemble at 10N M (7ft-lbf) torque)
  - (2) Do not disconnect the airbag connector.
  - (3) Place the airbag assembly on a soft cover on the floor.



**NOTE:** When handling the airbag assembly, take care not to damage the airbag wire harness.

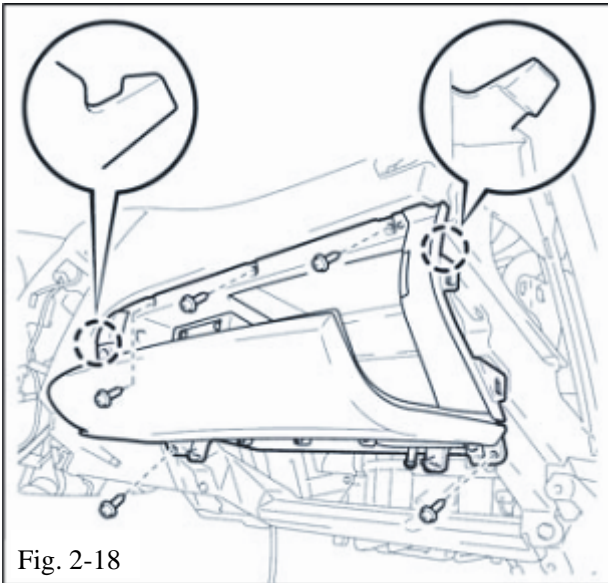

- (4) Remove Glove Box Assembly.
- (k) Remove the 5 screws, and then pull outward to remove the glove compartment door as shown. (Fig. 2-18)
  - (1) Disconnect any connectors.

- (l) Temporarily reinstall the airbag assembly.

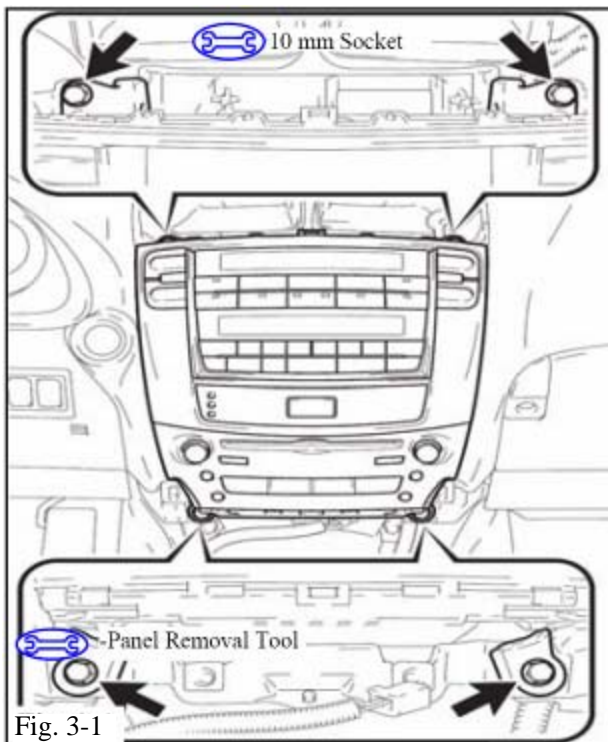

### 3. Remove the Head Unit.

- (a) Remove the two (2) 10 mm bolts on top and the two (2) 10 mm bolts on the bottom. (Fig. 3-1)



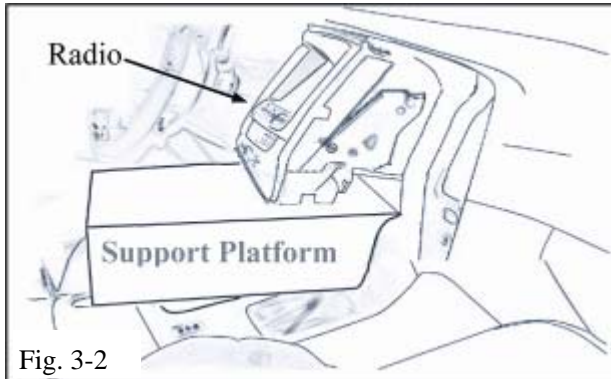

- ⚠ (b) Gently pull out the radio cluster in order to access the plug-in location and rest on a support platform to prevent scratching of dash panels. (Fig. 3-2)

⚠ **NOTE:** Be careful not to put too much tension on the radio wire harness when pulling out the radio.

#### 4. Install the Interface Unit and Route the AVC-LAN Cable and the iPod Cable

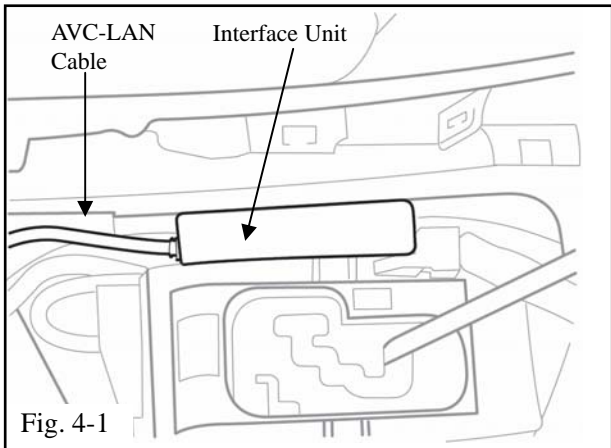

- (a) Connect the iPod cable to the interface unit.
- (b) Install the foam sleeve over the iPod chassis.
- (c) Carefully insert the interface unit into the open space next to the shift lever with the AVC-LAN cable routed toward the rear of the vehicle. (Fig. 4-1)

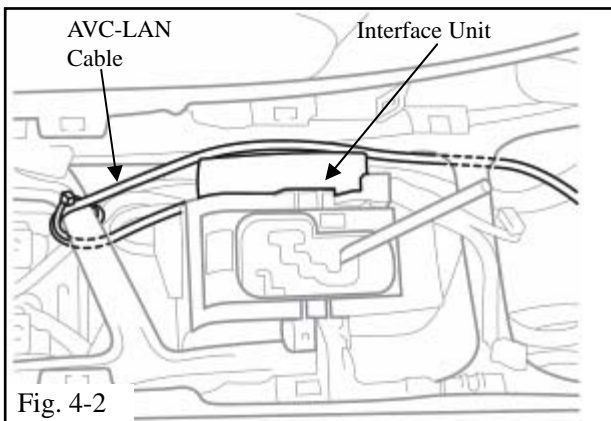

- (d) Route the AVC-LAN cable under, then back up and over the vehicle bar in the center console as shown. (Fig. 4-2)
- (1) Secure the cable with a 6" lock tie. (Fig. 4-2)

**NOTE:** Trim excess from all lock ties after tightening.

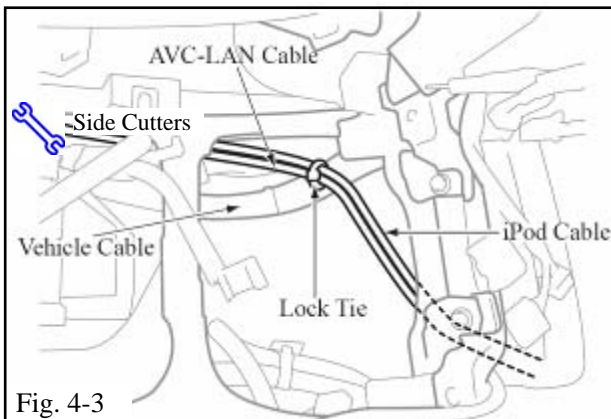

- (e) Continue to route the AVC-LAN cable toward the audio head unit, passing it to the driver's side of the interface unit, and continuing under the front vehicle bar in the center console. (Fig. 4-2)
- (f) Secure the AVC-LAN cable and the iPod cable together to the existing vehicle wiring using a 6" lock tie. (Fig. 4-3)

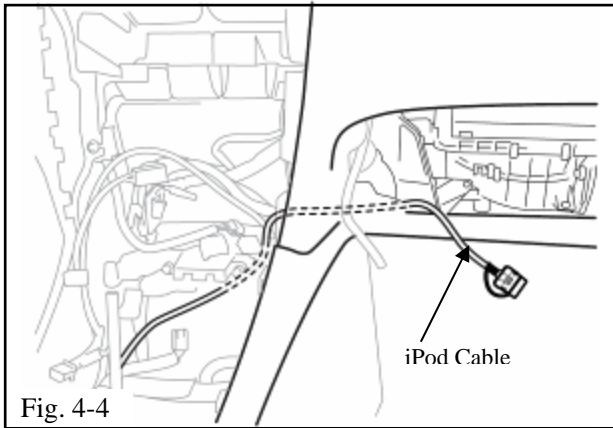

(g) Route the iPod cable through the head unit area toward the glove box. (Fig. 4-4)

**NOTE:** If the 12 pin connector is already pre-wired to the head unit, proceed to step (g). If the 12 pin connector is not pre-wired to the head unit, proceed to step (h).

(h) The 12 pin connector is already pre-wired to the head unit.

(1) Remove the pre-wired 12 pin connector from the head unit.

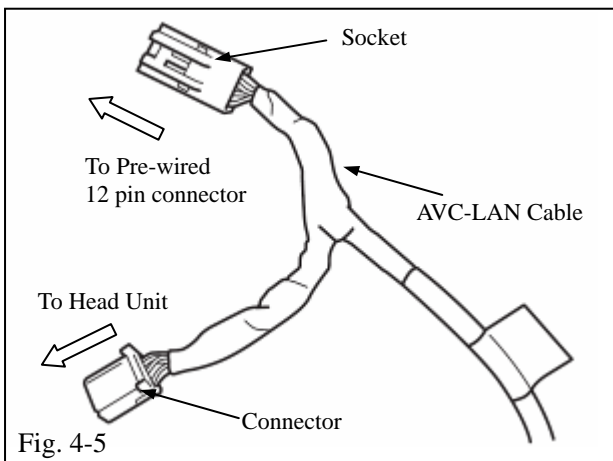

(2) Plug the pre-wired 12 pin connector into the socket of the AVC-LAN cable. (Fig. 4-5 & 4-6)

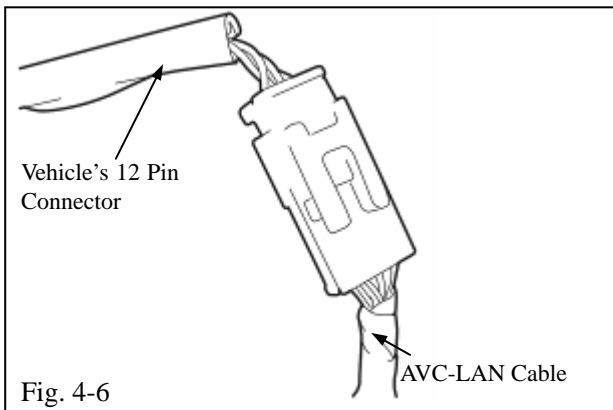

(3) Wrap the connectors with adhesive protective foam to secure. (Fig. 4-7)

(4) Plug the connector of the AVC-LAN cable into the head unit. (Fig. 4-8)

(5) Reconnect the factory harness and antenna.

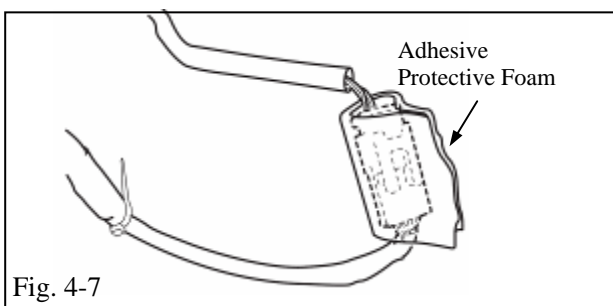

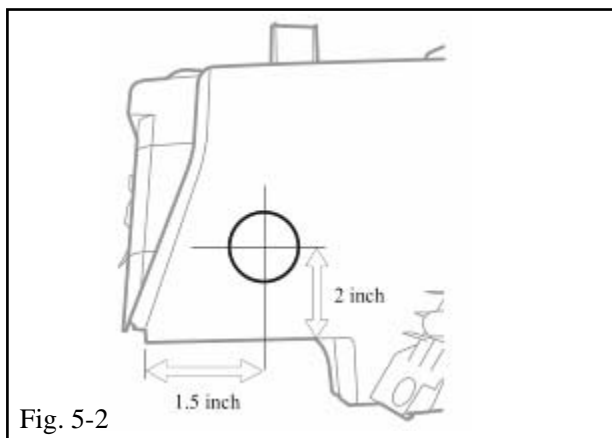
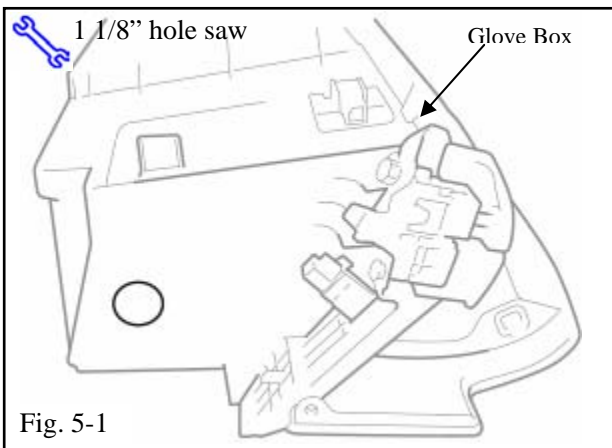
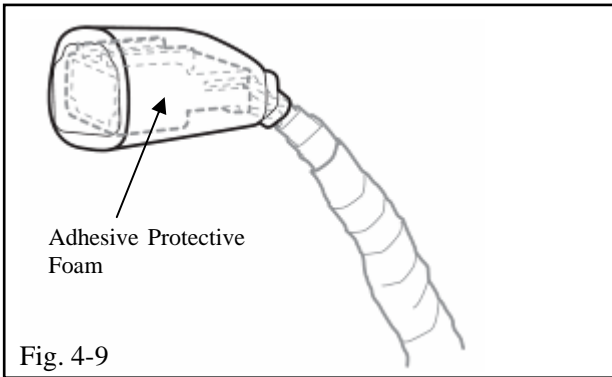
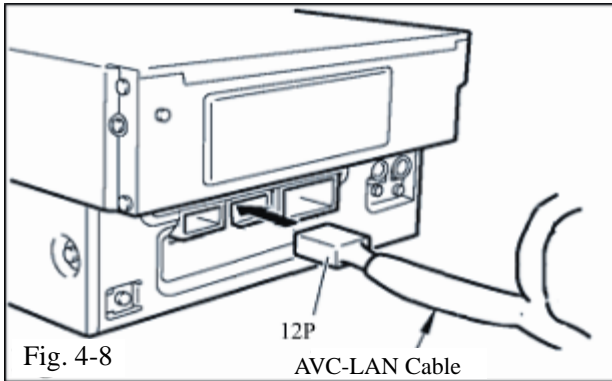

- (i) The 12 pin connector is not pre-wired to the head unit.
  - (1) Plug the connector of the AVC-LAN cable into the head unit. (Fig. 4-8)
  - (2) Wrap the unused socket of the AVC-LAN cable in adhesive protective foam. (Fig. 4-9)
- (j) Reconnect the factory harness and antenna.
- (k) Insert the head unit into opening and re-install the four bolts.
- (l) Place the radio cluster back into position.
- (m) Be careful not to crimp any of the factory harnesses or the AVC-LAN cable when replacing the radio.



### 5. Route the iPod Cable Terminal.

- (a) Make a round hole through which the cable can pass at the location on the glove box shown in the illustration. (Fig. 5-1 & 5-2)
  - (1) Hole saw is 1 1/8" (29 mm).

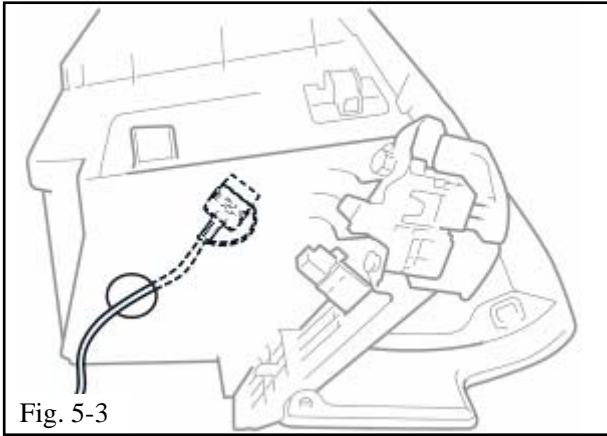

(b) Route the iPod cable through the hole from outside of the glove box. (Fig. 5-3)

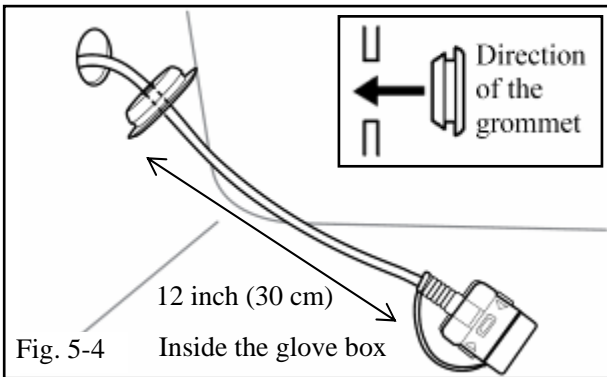

(c) Apply the grommet to the iPod cable. The distance from the grommet to iPod connector terminal should be approx. 12 inch. (Fig. 5-4)

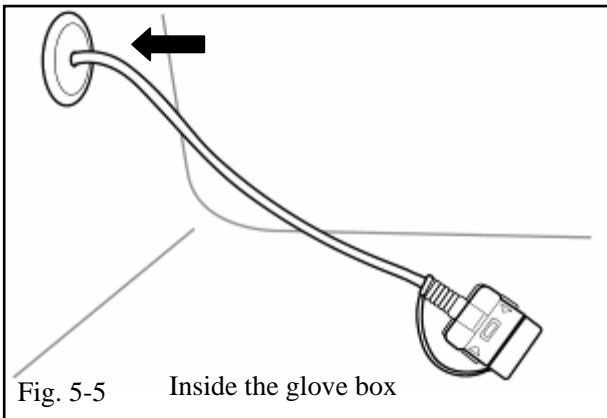

(d) Secure the grommet to the hole from the inside of the glove box. (Fig. 5-5)



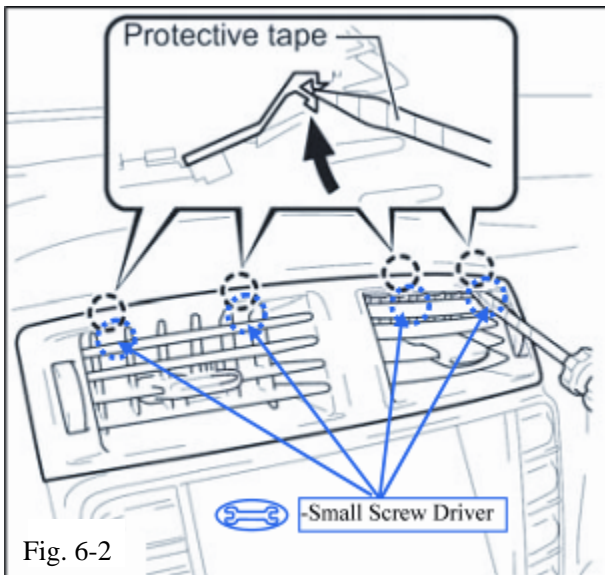
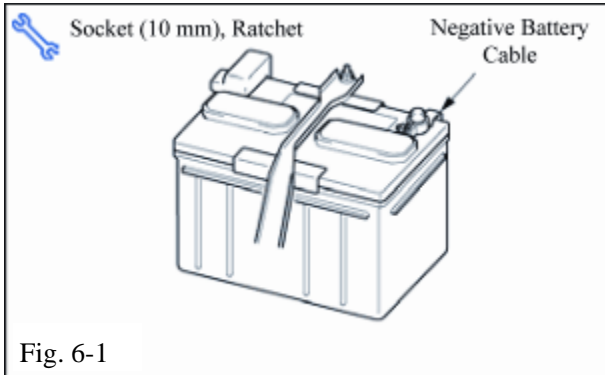

### 6. Reassemble Vehicle

(a) Reassemble vehicle in opposite order that it was disassembled.

(1) Torque knee air bag bolts at 10N M (7ft-lbf).

**NOTE:** When replacing the upper vents trim piece, make sure the 4 top clips are returned to their original upward position. (Fig. 6-2)

(b) Reconnect the negative terminal back to its original position. (Fig. 6-1)



(1) Tighten the nut with 4.1 N•m (36 lbf-in) of torque.



(2) Be careful not to touch the positive battery terminal.

(c) Clean up and remove any trash.



(d) Place the "Interface Kit for iPod" owner's manual in the glove box.

**LEXUS IS350 2008 – INTERFACE KIT for iPod**

Checklist - these points **MUST** be checked to ensure a quality installation.

<u>Check:</u>	<u>Look For:</u>
<p><u>Accessory Function Checks</u></p> <p><input type="checkbox"/> Interface Kit</p> <p><input type="checkbox"/> Receiver/player Assembly.</p>	<p>*Verify the proper connection of interface kit by using the checker.</p> <p>*Verify the proper operation of the Receiver/player Assembly</p> <p>*Verify both AM &amp; FM have good reception.</p> <p>*(Refer to the receiver assembly and radio owner’s manuals.)</p>
<p><u>Vehicle Function Checks</u></p> <p><input type="checkbox"/> Hazard switch.</p> <p><input type="checkbox"/> HVAC.</p> <p><input type="checkbox"/> Multi-information displays. (Clock, Temp., and MPG meter)</p> <p><input type="checkbox"/> Operation of the 12V outlet switch.</p> <p><input type="checkbox"/> Aux Input Jack.</p> <p><input type="checkbox"/> NAV Antenna Functioning.</p>	<p>Proper operation of the hazard switch.</p> <p>Proper operation of the air conditioning system.</p> <p>Verify the proper operation of the multi-information displays.</p> <p>Verify the proper operation of the 12V outlet switch.</p> <p>Verify the Auxiliary Input Jack is working properly</p> <p>Confirm navigation operation by AVN diagnostics.</p>