

RADIO AND PLAYER (EXCEPT NAKAMICHI)

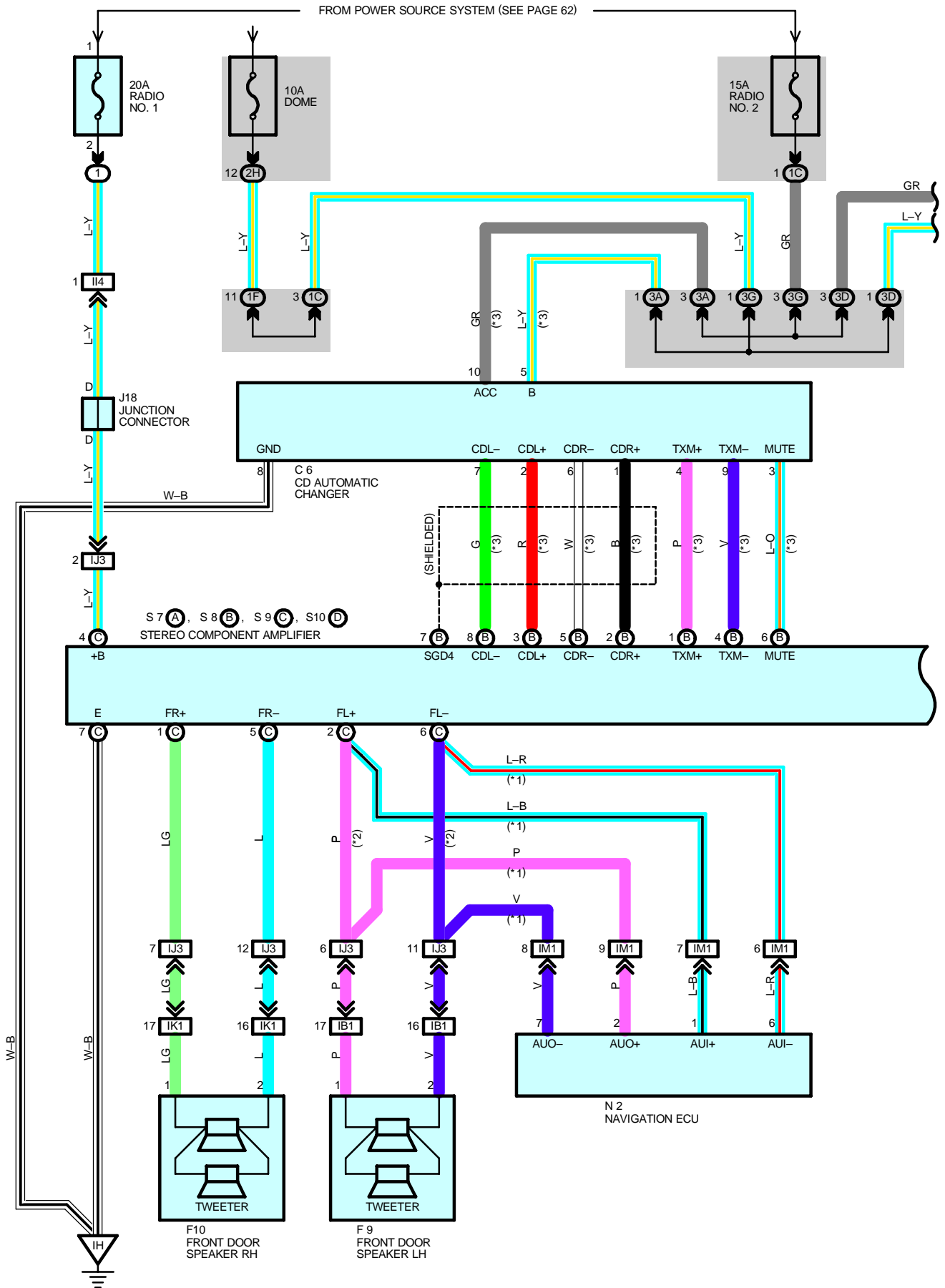

- * 1 : W/ LEXUS NAVIGATION SYSTEM
- * 2 : W/O LEXUS NAVIGATION SYSTEM
- * 3 : W/ CD AUTOMATIC CHANGER
- * 4 : W/ AUTO ANTENNA

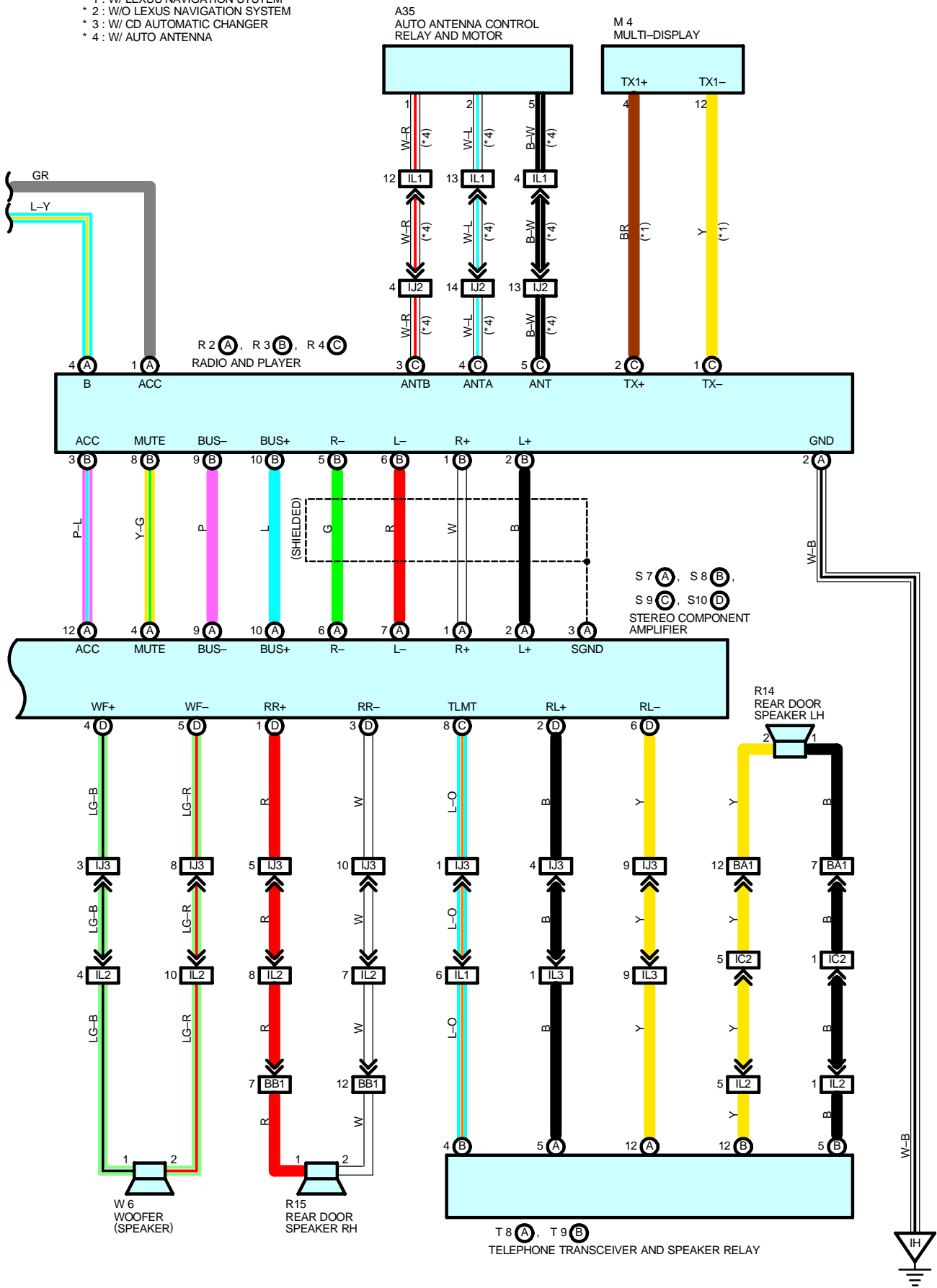

RADIO AND PLAYER (EXCEPT NAKAMICHI)

SERVICE HINTS

R2 (A) RADIO AND PLAYER

- (A) 1-GROUND : Approx. 12 volts with ignition SW at **ACC** or **ON** position
- (A) 4-GROUND : Always approx. 12 volts
- (A) 2-GROUND : Always continuity

S9 (C) STEREO COMPONENT AMPLIFIER

- (C) 4-GROUND : Always approx. 12 volts
- (C) 7-GROUND : Always continuity

C6 CD AUTOMATIC CHANGER

- 5-GROUND : Always approx. 12 volts
- 10-GROUND : Approx. 12 volts with ignition SW at **ACC** or **ON** position
- 8-GROUND : Always continuity

○ : PARTS LOCATION

Code	See Page	Code	See Page	Code	See Page
A35	44	R2	A 43	S9	C 43
C6	42	R3	B 43	S10	D 43
F9	44	R4	C 43	T8	A 45
F10	44	R14	45	T9	B 45
J18	43	R15	45	W6	45
M4	43	S7	A 43		
N2	45	S8	B 43		

○ : RELAY BLOCKS

Code	See Page	Relay Blocks (Relay Block Location)
1	24	Engine Room No.1 R/B (Engine Compartment Right)

○ : JUNCTION BLOCK AND WIRE HARNESS CONNECTOR

Code	See Page	Junction Block and Wire Harness (Connector Location)
1C	28	Instrument Panel Wire and Driver Side J/B (Left Kick Panel)
1F	28	Cowl Wire and Driver Side J/B (Left Kick Panel)
2H	31	Cowl Wire and Passenger Side J/B (Right Kick Panel)
3A	32	Instrument Panel Wire and Instrument Panel J/B (Instrument Panel Reinforcement Center)
3D		
3G		

□ : CONNECTOR JOINING WIRE HARNESS AND WIRE HARNESS

Code	See Page	Joining Wire Harness and Wire Harness (Connector Location)
IB1	52	Front Door LH Wire and Cowl Wire (Left Kick Panel)
IC2	52	Floor No.2 Wire and Cowl Wire (Left Kick Panel)
II4	54	Engine Room Main Wire and Cowl Wire (Near the Passenger Side R/B)
IJ2	54	Instrument Panel Wire and Cowl Wire (Left Side of the Blower Unit)
IJ3		
IK1	54	Front Door RH Wire and Cowl Wire (Right Kick Panel)
IL1	54	Floor No.1 Wire and Cowl Wire (Right Kick Panel)
IL2		
IL3		
IM1	54	Instrument Panel Wire and Floor No.1 Wire (Front RH Side of the Shift Lever)
BA1	56	Rear Door LH Wire and Floor No.2 Wire (Under the Center Pillar LH)
BB1	56	Rear Door RH Wire and Floor No.1 Wire (Under the Center Pillar RH)

▽ : GROUND POINTS

Code	See Page	Ground Points Location
IH	52	Instrument Panel Brace RH

