

ENGINE COOLANT TEMPERATURE (ECT) SENSOR

EG1PK-01

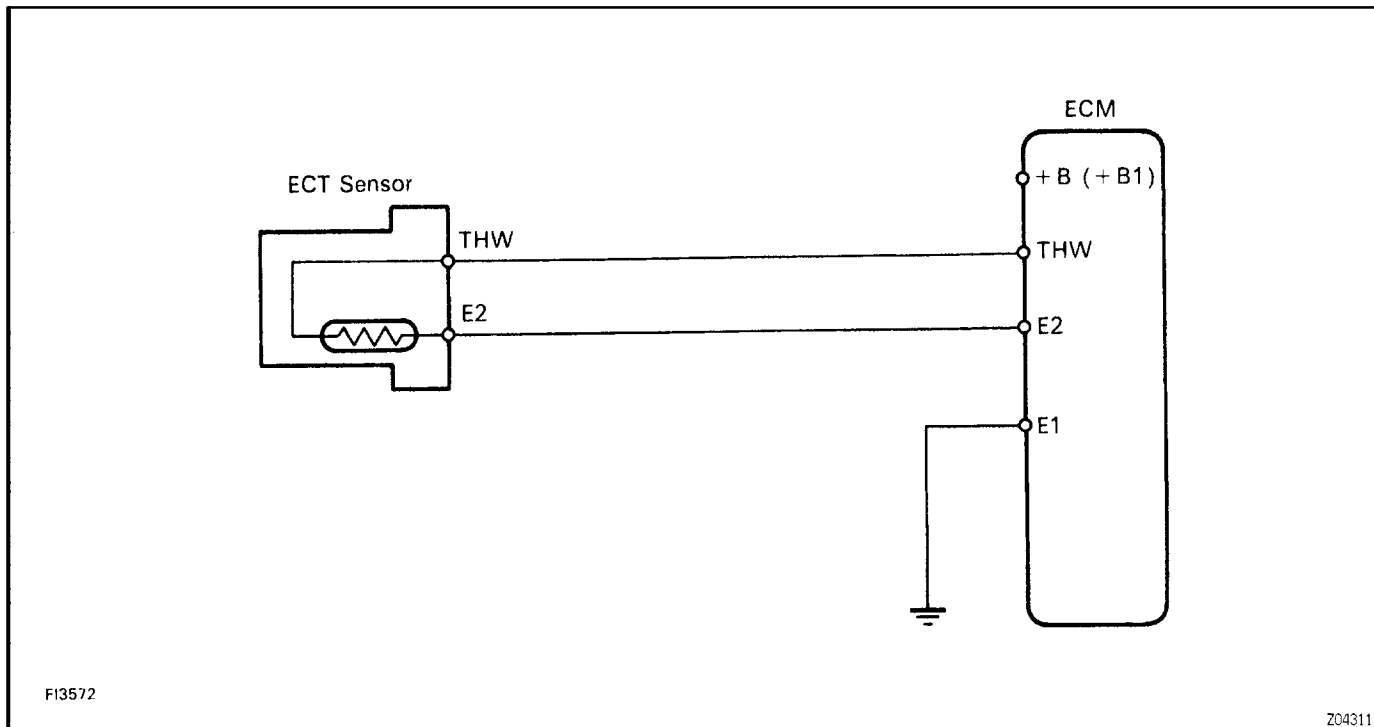

F13572

Z04311

COMPONENTS FOR REMOVAL AND INSTALLATION

EG1PL-01

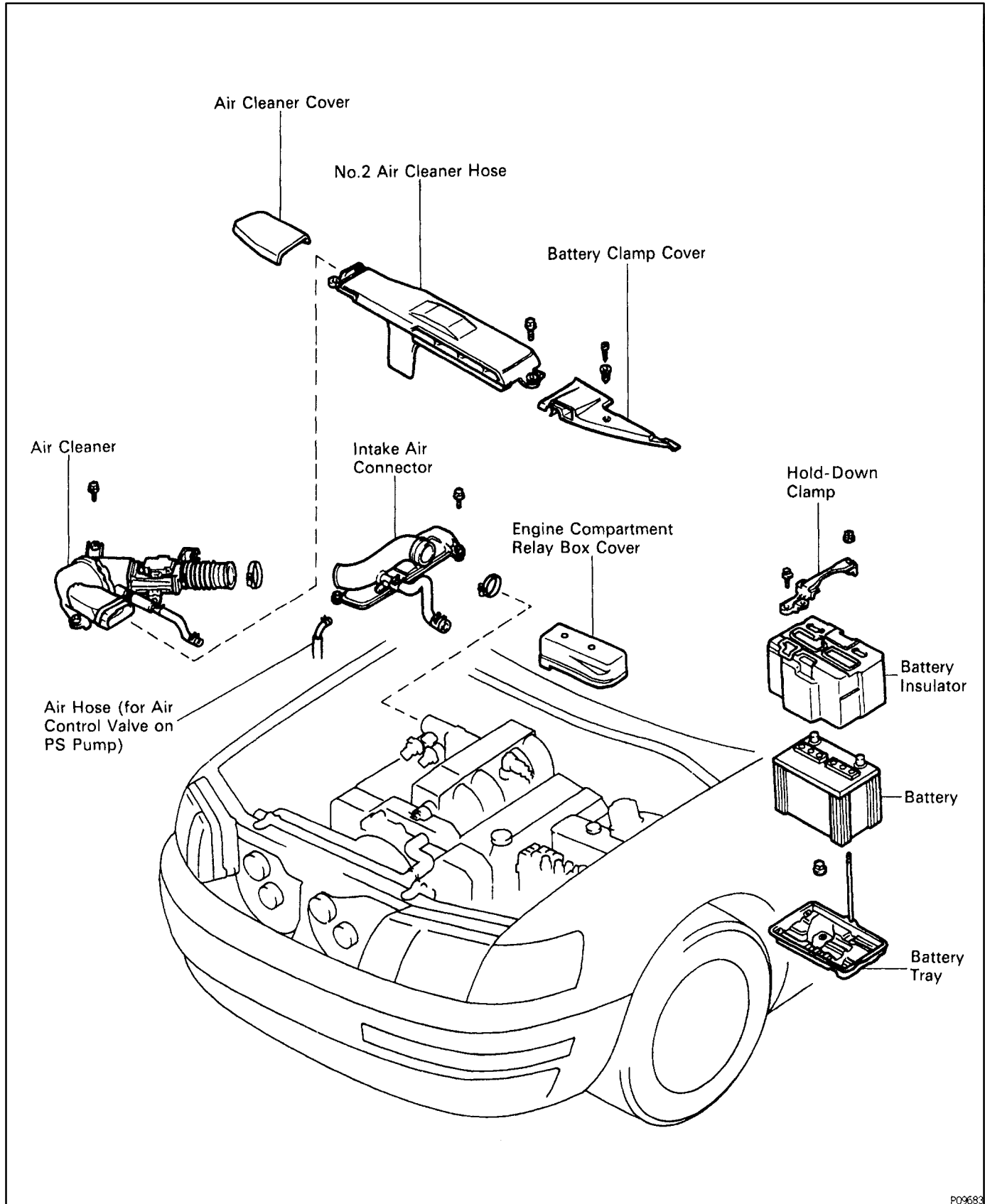

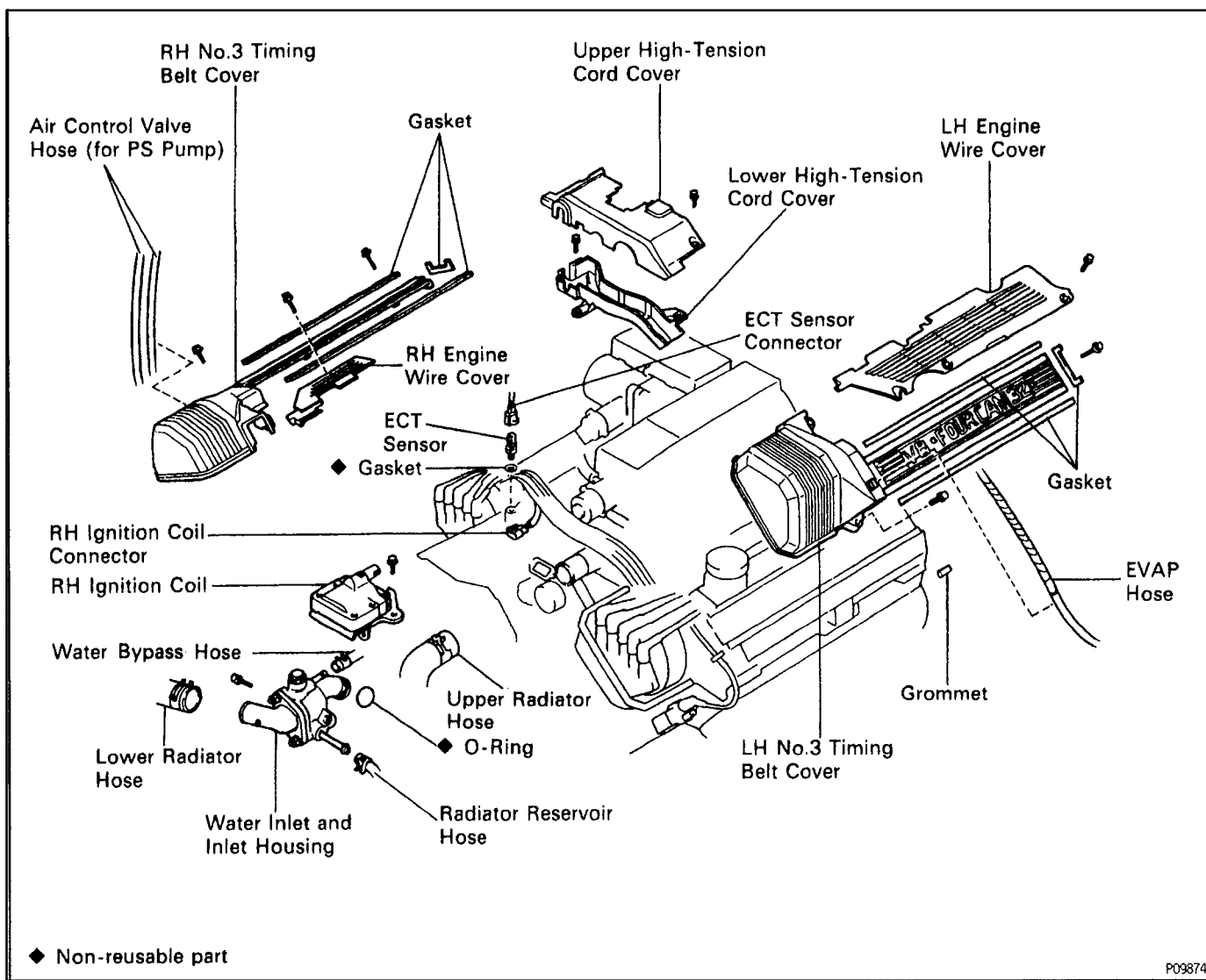

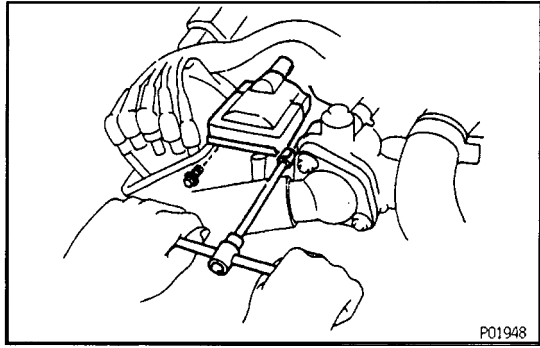

ECT SENSOR INSPECTION

EG1PM-02

1. **REMOVE LOWER HIGH-TENSION CORD COVER**
(See page 1, 8 and 11 to 19 on pages [EG-323 to 326](#))

2. **REMOVE RH IGNITION COIL**

- (a) Disconnect the ignition coil connector.
- (b) Remove the 2 bolts, and disconnect the ignition coil.

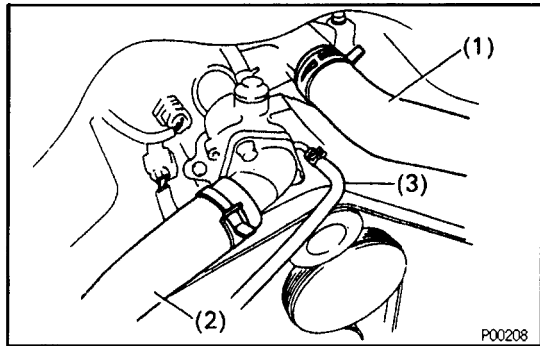

3. **DISCONNECT HOSES**

Disconnect the following hoses:

- (1) Upper radiator hose from front water bypass joint
- (2) Lower radiator hose from water inlet
- (3) Radiator reservoir hose from front water inlet housing

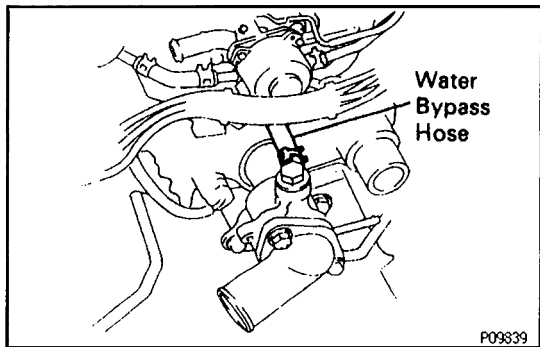

4. **REMOVE WATER INLET AND INLET HOUSING**

- (a) Disconnect the water bypass hose from the water inlet housing.

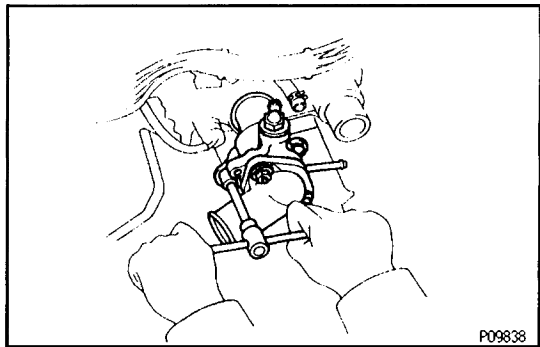

- (b) Remove the 2 bolts holding the water inlet housing to the water pump.
- (c) Pull out the water inlet and inlet housing assembly.
- (d) Remove the O-ring from the water inlet housing.

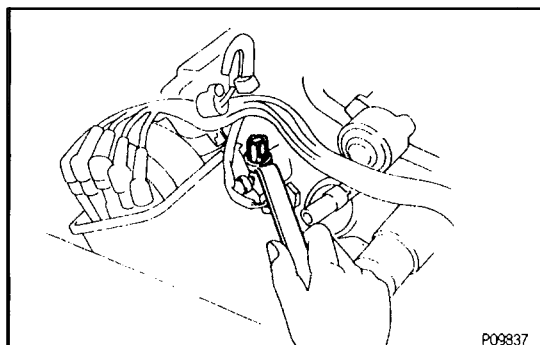

5. **REMOVE ECT SENSOR**

- (a) Disconnect the ECT sensor connector.
- (b) Remove the ECT sensor and gasket.

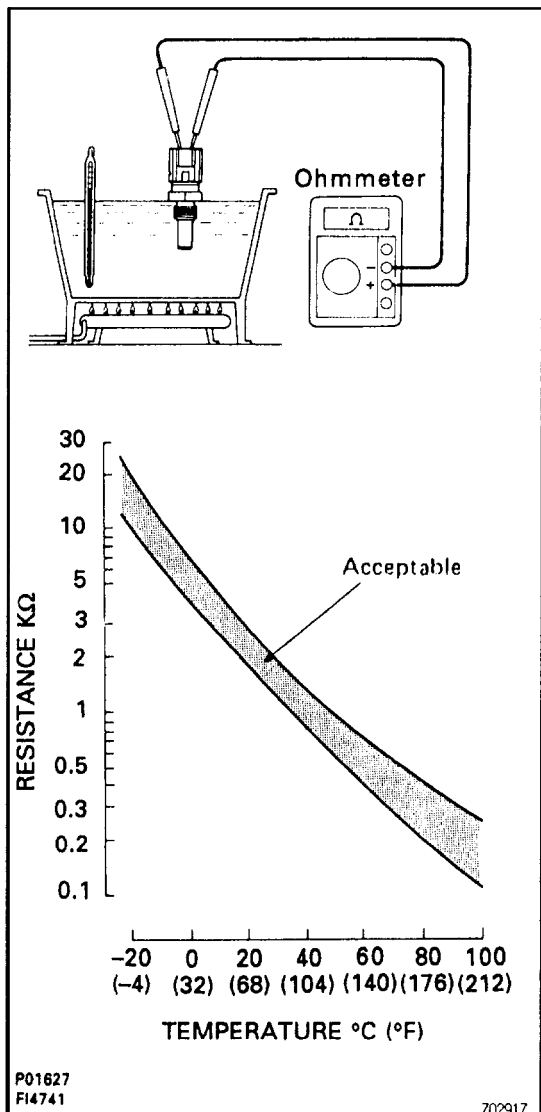

6. INSPECT ECT SENSOR

Using an ohmmeter, measure the resistance between the terminals.

Resistance: Refer to the chart graph

If the resistance is not as specified, replace the sensor.

7. REINSTALL ECT SENSOR

- Install a new gasket to the ECT sensor.
- Install the ECT sensor.

Torque: 20 N·m (200 kgf·cm, 14 ft·lbf)

- Connect the ECT sensor connector.

8. REINSTALL WATER INLET AND INLET HOUSING

- Remove any old packing (FIPG) material and be careful not to drop any oil on the contact surfaces of the water inlet housing and water pump.
 - Using a razor blade and gasket scraper, remove all the old packing (FIPG) material from the gasket surfaces and sealing groove.
 - Thoroughly clean all components to remove all the loose material.
 - Using a non-residue solvent, clean both sealing surfaces.

- Apply seal packing to the sealing groove of the water inlet housing as shown in the illustration.
 - Install a nozzle that has been cut to a 2–3 mm (0.08–0.12 in.) opening.

Seal packing: Part No.08826-00010 or equivalent

- Install a nozzle that has been cut to a 2–3 mm (0.08–0.12 in.) opening.

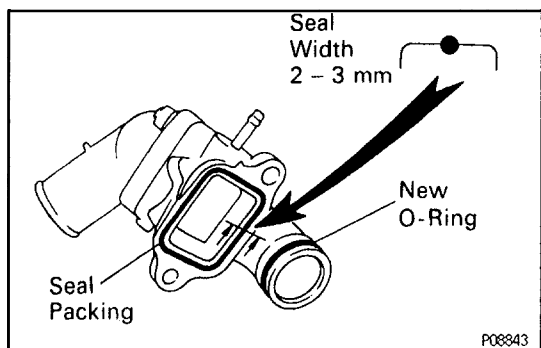

HINT: Avoid applying an excessive amount to the surface.

- Parts must be assembled within 5 minutes of application. Otherwise the material must be removed and reapplied.
 - Immediately remove nozzle from the tube and reinstall cap.
- Install a new O-ring to the water inlet housing.
 - Apply soapy water to the O-ring.

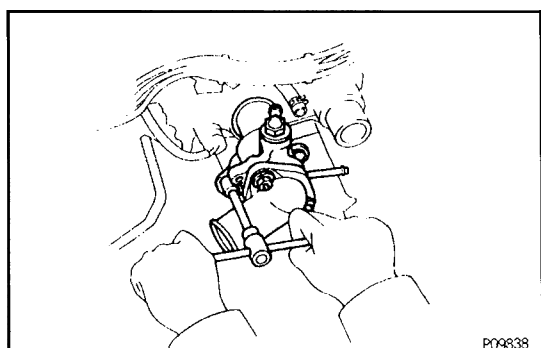

- Push in the water inlet housing end into the water pump hole.
- Install the water inlet and inlet housing assembly with the 2 bolts. Alternately tighten the bolts.

Torque: 18 N·m (185 kgf·cm, 13 ft·lbf)

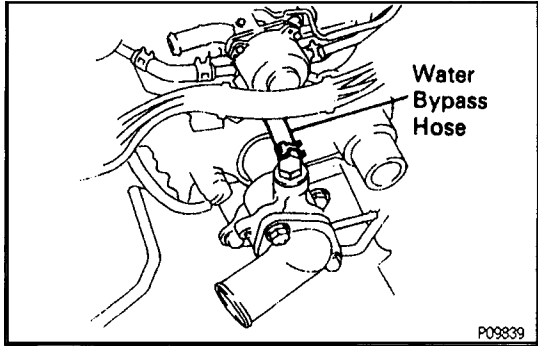

- (g) Connect the water bypass hose to the water inlet housing.

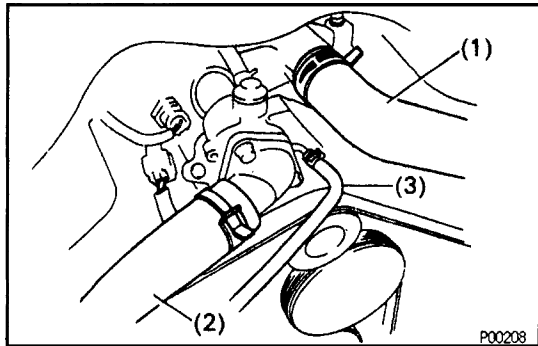

9. RECONNECT HOSES

Connect the following hoses:

- (1) Upper radiator hose to front water bypass joint
- (2) Lower radiator hose to water inlet
- (3) Radiator reservoir hose to front water inlet

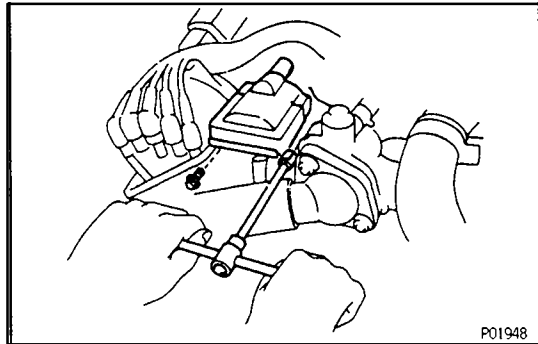

10. REINSTALL RH IGNITION COIL

- (a) Install the ignition coil with the 2 bolts.
- (b) Connect the ignition coil connector.

11. REINSTALL LOWER HIGH-TENSION CORD COVER (See steps 12 to 19 and 22 to 30 on pages EG-338 to 341)